

Université de Montréal

Unfolded singularities of analytic differential equations

par

Martin Klimeš

Département de mathématiques et de statistique
Faculté des arts et des sciences

Thèse présentée à la Faculté des études supérieures
en vue de l'obtention du grade de
Philosophiæ Doctor (Ph.D.)
en mathématiques
orientation mathématiques fondamentales

19 Juin 2014

Université de Montréal

Faculté des études supérieures

Cette thèse intitulée

Unfolded singularities of analytic differential equations

présentée par

Martin Klimeš

a été évaluée par un jury composé des personnes suivantes :

Marlène Frigon

(président-rapporteur)

Christiane Rousseau

(directeur de recherche)

Jacques Bélair

(membre du jury)

Alexey Glutsyuk

(examineur externe)

Fabian Bastin

(représentant du doyen de la FAS)

Thèse acceptée le

19 Juin 2014

For Ernie & Millie

SOMMAIRE

La thèse est composée d'un chapitre de préliminaires et de deux articles sur le sujet du déploiement de singularités d'équations différentielles ordinaires analytiques dans le plan complexe.

L'article *Analytic classification of families of linear differential systems unfolding a resonant irregular singularity* traite le problème de l'équivalence analytique de familles paramétriques de systèmes linéaires en dimension 2 qui déploient une singularité résonante générique de rang de Poincaré 1 dont la matrice principale est composée d'un seul bloc de Jordan. La question: quand deux telles familles sont-elles équivalentes au moyen d'un changement analytique de coordonnées au voisinage d'une singularité? est complètement résolue et l'espace des modules des classes d'équivalence analytiques est décrit en termes d'un ensemble d'invariants formels et d'un invariant analytique, obtenu à partir de la trace de la monodromie. Des déploiements universels sont donnés pour toutes ces singularités.

Dans l'article *Confluence of singularities of non-linear differential equations via Borel–Laplace transformations* on cherche des solutions bornées de systèmes paramétriques des équations non-linéaires de la variété centre de dimension 1 d'une singularité col-nœud déployée dans une famille de champs vectoriels complexes. En général, un système d'ÉDO analytiques avec une singularité double possède une unique solution formelle divergente au voisinage de la singularité, à laquelle on peut associer des vraies solutions sur certains secteurs dans le plan complexe en utilisant les transformations de Borel–Laplace. L'article montre comment généraliser cette méthode et déployer les solutions sectorielles. On construit des solutions de systèmes paramétriques, avec deux singularités régulières déployant une singularité irrégulière double, qui sont bornées sur des domaines «spirals» attachés aux deux points singuliers, et qui, à la limite, convergent vers une paire de solutions sectorielles couvrant un voisinage de la singularité confluente. La méthode apporte une description unifiée pour toutes les valeurs du paramètre.

Mots-clés: Phénomène de Stokes, singularité irrégulière, système paramétrique, équations différentielles analytiques, déploiement, confluence, série asymptotique, sommation de Borel, singularité col-nœud, forme normale.

SUMMARY

The thesis is composed of a chapter of preliminaries and two articles on the theme of unfolding of singularities of analytic differential equations in a complex domain. They are both related to the problem of local analytic classification of parametric families of linear systems: When two parametric families of linear systems are equivalent by means of an analytic change of coordinates in a neighborhood of the singularity?

The article *Analytic classification of families of linear differential systems unfolding a resonant irregular singularity* deals with the question of analytic equivalence of parametric families of systems of linear differential equations in dimension 2 unfolding a generic resonant singularity of Poincaré rank 1 whose leading matrix is a Jordan bloc. The problem is completely solved and the moduli space of analytic equivalence classes is described in terms of a set of formal invariants and a single analytic invariant obtained from the trace of the monodromy. Universal unfoldings are provided for all such singularities.

The article *Confluence of singularities of non-linear differential equations via Borel-Laplace transformations* investigates bounded solutions of systems of differential equations describing a 1-dimensional center manifold of an unfolded saddle-node singularity in a family of complex vector fields. Generally, a system of analytic ODE at a double singular point possesses a unique formal solution in terms of a divergent power series. The classical Borel summation method associates to it true solutions that are asymptotic to the series on certain sectors in the complex plane. The article shows how to unfold the Borel and Laplace integral transformations of the summation procedure. A new kind of solutions of parameter dependent systems of ODE with two simple (regular) singular points unfolding a double (irregular) singularity are constructed, which are bounded on certain “spiraling” domains attached to both singular points, and which at the limit converge uniformly to a pair of the classical sectorial solutions. The method provides a unified treatment for all values of parameter.

Key words: Stokes phenomenon, irregular singularity, parametric systems, analytic differential equations, unfolding, confluence, divergent asymptotic series, Borel summation, saddle-node singularity, normal forms.

CONTENTS

Sommaire	iii
Summary	v
Remerciements	ix
Introduction	1
0.1. On analytic classification of singularities of linear differential systems .	2
0.2. On the Borel–Laplace transformations and their unfolding	4
Chapter 1. Preliminaries	7
1.1. Summation of divergent series	7
1.1.1. Asymptotic series	7
1.1.2. Borel summability	8
1.1.3. k -summability	10
1.2. Poincaré–Dulac theory of vector fields	11
1.3. Analytic classification of singularities of linear differential systems	12
1.3.1. Non-resonant irregular singularities.....	14
Chapter 2. Analytic classification of families of linear differential systems unfolding a resonant irregular singularity	17
2.1. Introduction	17
2.2. Statement of results	19
2.2.1. Analytic theory	20
2.2.2. Formal theory and a study of confluence	22
2.3. Proofs	26
2.3.1. Prenormal form.	26
2.3.2. Proof of Theorem II.....	28

2.3.3.	Systems in the s -coordinate.	30
2.3.4.	\mathbb{Z}_2 -symmetry.	32
2.3.5.	Solution p_i of (2.3.24) on a ramified domain D_i	33
2.3.6.	Domains Ω and normalizing transformations F_Ω	35
2.3.7.	Connection matrices and proof of Theorem I (a).	46
Chapter 3. Confluence of singularities of non-linear differential equations via Borel-Laplace transformations.		59
3.1.	Introduction.	59
3.2.	Statement of results.	61
3.2.1.	Borel-Laplace transformations and their unfolding.	61
3.2.2.	Center manifold of an unfolded codimension 1 saddle-node type singularity.	63
3.2.3.	Sectoral normalization of families of non-resonant linear differential systems.	70
3.3.	Preliminaries on Fourier-Laplace transformations.	71
3.3.1.	Convolution of analytic functions on open strips.	74
3.3.2.	Dirac distributions in the Borel plane.	75
3.4.	The Borel and Laplace transformations associated to the vector field $(x^2 - \epsilon) \frac{\partial}{\partial x}$	76
3.4.1.	Remark on Fourier expansions.	82
3.5.	Solution to the equation (3.2.11) in the Borel plane.	83
Conclusion.		95
Bibliography.		97

REMERCIEMENTS

Je voudrais, en premier lieu, exprimer ma profonde gratitude à ma directrice de recherche, Christiane Rousseau, qui m'a introduit au monde des équations différentielles analytiques et qui m'a guidé avec ses précieux conseils durant ces cinq dernières années, et sans qui ce travail n'aurait pas vu le jour. Je la remercie pour sa patience, sa disponibilité, son encouragement et son intérêt constant. Je lui exprime aussi toute ma reconnaissance pour son soutien financier.

Je remercie tous les membres du Département de mathématiques et de statistique de l'Université de Montréal et de la communauté mathématique de Montréal, de m'avoir accueilli dans leurs structures et d'avoir créé une ambiance de travail très inspirante.

Je remercie Alexey Glutsyuk de m'avoir invité à assister à la conférence «Attractors, Foliations and Limit Cycles» à Moscou en janvier 2014 et à exposer sous forme d'affiches mes résultats.

Finalement, je remercie mes proches, mes parents, mes grands-parents et Angie, d'être si aimables, de me soutenir et de me redonner confiance en tout temps.

INTRODUCTION

The use of divergent formal power series solutions of meromorphic differential equations near a singular point has a long and fruitful tradition. In case of a multiple singular point their divergence is the general rule. It is known that one can always construct true analytic solutions, defined on certain sectors attached to the singularity, which are asymptotic to the formal series, and which are in some sense unique. In the case where the singularity is not too degenerate, the method of construction of such sectorial solutions is called the Borel summation, or k -summation (where $k + 1$ is in the generic case the multiplicity of the singularity), while in the very general case the method is called accelero-summation (or multisummation). Based on an original idea of É. Borel from the end of the 19th century, it has been largely developed during 1970–1980's by J. Écalle (cf. [Ec]), and by J.-P. Ramis (cf. [Ra3]), and became one of the main tools in the local study of singularities of analytic differential equations. In general, the solutions on different sectors do not coincide, and if extended to larger sectors, they may drastically change their asymptotic behavior due to the presence of hidden exponentially small terms. This is traditionally known as the (linear or non-linear) Stokes phenomenon. It is now understood, that the divergence of the asymptotic series is caused by singularities of its Borel transform, which also encode information on the geometry of the singularity.

The work in this thesis is part of a general program of studying parametric families of differential systems unfolding such multiple singularities in several simple ones. There are two basic goals for such an investigation:

1. To provide normal forms for germs of analytic unfoldings of singularities with respect to analytic change of variables.
2. To explain the complex geometry of the multiple singularity and the Stokes phenomena through a study of confluence of simple singularities. Generically, analytic ODEs possess special particular local analytic solutions near simple singularities, but there is no reason why they should match. Hence their limits as the parameter tends to zero may only exist in sectors.

The thesis is composed of two parts, corresponding to two of my papers, addressing two particular problems within the outlined framework.

The first article

[K1] M. Klimeš, *Analytic classification of families of linear differential systems unfolding a resonant irregular singularity*, preprint (2013),

presented in Chapter 2, deals with the question of analytic equivalence of certain parametric families of linear differential systems unfolding a generic resonant irregular singularity of Poincaré rank 1 in dimension 2.

The second article

[K2] M. Klimeš, *Confluence of singularities of non-linear differential equations via Borel-Laplace transformations*, preprint (2013),

presented in Chapter 3, shows how to generalize the Borel method of summation of 1-summable formal series in order to investigate bounded solutions of systems of non-linear differential equations describing a center manifold of an unfolded saddle-node singularity of a parametric family of complex vector fields.

The problems addressed in each of the two articles are presented below.

0.1. ON ANALYTIC CLASSIFICATION OF SINGULARITIES OF LINEAR DIFFERENTIAL SYSTEMS

A meromorphic linear differential system with a singularity at the origin is written locally as

$$x^{k+1} \frac{dy}{dx} = A_0(x) y, \quad x \in (\mathbb{C}, 0), \quad (0.1.1)$$

where A_0 is an analytic matrix in neighborhood of 0 with $A_0(0) \neq 0$, $y(x) \in \mathbb{C}^n$, and k is a non-negative integer, called the *Poincaré rank*.

The problem of analytic classification consists in determining when two germs of systems can be transformed one to another by means of an analytic linear change of the variable y , and in describing the moduli space of the equivalence classes.

This can be rephrased as a problem of existence of local isomorphisms between parametric families of meromorphic connections on vector bundles on Riemann surfaces, as well as of existence of local coordinates in which they have certain canonical form as simple as possible (e.g. diagonal). This is a problem with a long and rich history going back to B. Riemann and his work on the monodromy of the hypergeometric functions. In contrast to *regular*¹ singularities, which are analytically equivalent if and only if they are equivalent by means of a formal power series transformation,

¹The singularity at 0 of a system (0.1.1) is called *regular* if solutions have a moderate (power-like) growth near the singularity; else it is *irregular*.

in case of *irregular* singularities such formal transformations are generally divergent. In other words, the formal normal forms are too simple to contain all the possible complexities of the geometry of solutions near the irregular singular point.

The analytic classification of irregular singularities of systems (0.1.1) is now well known. It has been first achieved for *non-resonant*² irregular singularities by G.D. Birkhoff in 1910's, and completed in the general case during the 1980's in a series of works by W. Balser, W.B. Jurkat, B. Malgrange, J.-P. Ramis, Y. Sibuya and others (see [Va] and the references therein). The role that monodromy³ plays in the case of regular singularities is here embodied by a set of so called Stokes matrices: matrices of passage between solutions with the same asymptotics on neighboring sectors.

An unfolding of a system (0.1.1) is a germ of a parametric family of linear systems

$$h(x, m) \frac{dy}{dx} = A(x, m) y, \quad (x, m) \in (\mathbb{C} \times \mathbb{C}^l, 0), \quad (0.1.2)$$

with $h(x, 0) = x^{k+1}$ and $A(x, 0) = A_0(x)$, analytic in both the variable x and the parameter m . As before, two families of linear systems (0.1.2) depending on the same parameter m are said to be *analytically equivalent* if there is an invertible analytic linear gauge transformation bringing solutions of the first system to solutions of the second system.

The problem is to extend the analytic classification to parametric families of systems (0.1.2) unfolding an irregular singularity, and to understand the meaning of the Stokes data by relating the analytic invariants of the original system to the ones of the unfolded system. Relatively little has been written about this problem until recently (apart of the study of confluence of hypergeometric equation by J.P. Ramis, A. Duval, C. Zhang). It has been conjectured independently by V.I. Arnold, A. Bolibruch and J.-P. Ramis, and later proved by A. Glutsyuk [G1], [G3], that Stokes matrices of the limit problem (0.1.1) can be obtained as limits of transition matrices between certain canonical solution bases at the regular singular points of a generically perturbed system. All these works concern families depending on one generic parameter and are limited to confluence in some sector of opening less than 2π in the parameter space. Very recently a complete analytic classification of germs of parametric families of systems unfolding a *non-resonant* irregular singularity was obtained, first by C. Lambert in her thesis [LR] for singularities of Poincaré rank

²The irregular singularity at the origin of (0.1.1), $k \geq 1$, is *non-resonant* if the eigenvalues of the leading matrix $A_0(0)$ are distinct.

³Continuing a solution of a linear system around a singularity produces another solution of the system. This gives rise to the so called the *monodromy operator*, a linear representation associating to each loop from the fundamental group of the x -space punctured at the singularities an automorphisms of the linear space of solutions of the system.

$k = 1$, and later generalized to any Poincaré rank k by J. Hurtubise, C. Lambert and C. Rousseau [HLR].

My article [K1] gives a full classification of parametric families unfolding a *resonant* irregular singularity of Poincaré rank $k = 1$ and dimension $n = 2$, whose leading matrix is a Jordan bloc. The modulus of analytic equivalence of such parametric families is given by formal invariants and by an analytic invariant obtained from the trace of the monodromy around the two singular points. The moduli space is identified and an explicit polynomial normal form is provided for each equivalence class.

There are two essential parameters in the unfolding of such singularity: one parameter separates the double (irregular) singularity into two simple (regular) ones, the other separates the double (resonant) eigenvalue into two different (non-resonant) ones. Hence, apart from the phenomenon of confluence of singularities, a new phenomenon occurs which has not been studied before: a change of order of summability of the formal normalizing transformations from 1-summable for non-resonant irregular singularity to $\frac{1}{2}$ -summable for the limit resonant irregular singularity. They are both explained together with the Stokes phenomenon in the parametric family.

0.2. ON THE BOREL–LAPLACE TRANSFORMATIONS AND THEIR UNFOLDING

The classical Borel–Laplace method is used to find sums of divergent series obtained as formal solutions of ordinary differential equations near a singular point. A typical example is given by a center manifold of a codimension 1 saddle-node singularity of a complex analytic vector field. It is described by a non-linear system of ODEs with a double singularity at origin

$$x^2 \frac{dy}{dx} = M_0 y + f_0(x, y), \quad (x, y) \in \mathbb{C} \times \mathbb{C}^m, \quad (0.2.1)$$

where M_0 is an *invertible* matrix and $f_0(x, y) = O(x) + O(\|y\|^2)$ is a germ of analytic vector function. Such a system possesses a unique formal solution $\hat{y}_0(x) = \sum_{l=1}^{\infty} y_{l0} x^l$, which is generically divergent, however it is Borel 1-summable with unique sums defined in certain sectors of opening $> \pi$, covering a full neighborhood of the singularity. Hence, in general, no analytic center manifold of a saddle-node does exist, but instead there exist unique “sectoral center manifolds”. The goal of my article [K2] is to study how these sectoral center manifolds unfold in a parametric family of vector fields deforming the singularity.

In view of the fact that the classical Borel method does not allow to treat several singularities at one time, it is not suited for studying confluence in parametric families.

The article shows how one can generalize (unfold) the classical Borel–Laplace transformations, and use them to investigate bounded solutions in family of non-linear differential systems unfolding (0.2.1)

$$(x^2 - \epsilon) \frac{dy}{dx} = M(\epsilon)y + f(x, y, \epsilon), \quad (x, y, \epsilon) \in \mathbb{C} \times \mathbb{C}^m \times \mathbb{C}, \quad (0.2.2)$$

where $M(0)$ is an invertible matrix and $f(x, y, \epsilon) = O(\|y\|^2) + xO(\|y\|) + (x^2 - \epsilon)O(1)$.

It is well known that for generic (non-resonant) values of the parameter $\epsilon \neq 0$, there exists a local analytic solution on a neighborhood of each simple singularity $x = \pm\sqrt{\epsilon}$. Previous studies of confluence ([M],[SS],[G2]) have focused at the limit behavior of these local solutions when $\epsilon \rightarrow 0$. Because the resonant values of ϵ accumulate at 0 in a finite number of directions, these directions of resonance in the parameter space could not be covered in those studies. In my work, a new kind of solutions are constructed, which are defined and bounded on certain ramified domains attached to both singularities $x = \pm\sqrt{\epsilon}$ (at which they possess a limit) in a spiraling manner. They depend analytically on the parameter ϵ taken from a ramified sector of opening $> 2\pi$ (thus covering a full neighborhood of the origin in the parameter space, including those parameters values for which the unfolded system is resonant), and they converge uniformly, when ϵ tends radially to 0, to a pair of the classical sectoral solutions: Borel sums of the formal power series solution of the limit system (0.2.1), which are defined on two sectors covering a full neighborhood of the confluent double singularity at the origin. In fact, each such pair of the sectoral Borel sums for $\epsilon = 0$, unfolds to a unique above mentioned parametric solution.

A motivation for looking at these solutions came originally from [LR] where such solutions have been constructed in the particular case of systems of Riccati equations, using a different method. My work deals with the general case, from which the previous results follow as corollary. It also provides a new perspective, and an insight similar to that of the classical Borel–Laplace approach.

Chapter 1

PRELIMINARIES

Notation 1.0.1. Throughout the text, $\mathbb{N} = \{0, 1, 2, \dots\}$ denotes the set of non-negative integers, and $\mathbb{N}^* = \mathbb{N} \setminus \{0\}$.

1.1. SUMMATION OF DIVERGENT SERIES

Formal power series solutions of analytic ODEs near a multiple singular point are generically divergent. The idea of Borel summation is to associate to these series analytic functions uniquely defined on certain sectors, that are asymptotic to the formal series. It turns out, that these “sectorial sums” are in fact solutions to the original differential equation. What is crucial is the angular size of the sector: if the sector is too narrow many asymptotic functions exist; if, on the other hand, the sector is too wide, there may be none.

The material of this section largely follows the notes [Ma2], [MR2], [Ra3].

Definition 1.1.1. An *open sector* at the origin in the complex plane is a set

$$S = \{x \in \mathbb{C} : |x| < r, \beta_1 < \arg x < \beta_2\} \cup \{0\},$$

where $r > 0$ is its radius, and $0 < \beta_2 - \beta_1 \leq 2\pi$ is its *opening*. If $\beta_2 - \beta_1 > 2\pi$, one may define a *ramified sector* S by taking x from the “universal sector” $\tilde{\mathbb{C}}$, obtained by adjoining 0 to the universal covering $\tilde{\mathbb{C}}^*$ of $\mathbb{C}^* = \mathbb{C} \setminus \{0\}$. A *closed sector* is the topological closure of an open sector. For two sectors S and S' , we write $S' \subset\subset S$ if the closure of S' is contained in S .

1.1.1. *Asymptotic series*

If f is an analytic function on a sector S (i.e. continuous on S and analytic on its interior), then one says that f is *asymptotic* to a formal series $\hat{f}(x) = \sum_{k=0}^{+\infty} a_k x^k$ if for any closed subsector $S' \subset\subset S$ there exists a sequence of positive constants A_n ,

$n \in \mathbb{N}$, such that

$$\left| f(x) - \sum_{k=0}^{n-1} a_k x^k \right| \leq A_n |x|^n, \quad \text{for all } x \in S'.$$

The function f is said to be *asymptotic of Gevrey order s* to \hat{f} ($s > 0$), if $A_n \leq CA^n \Gamma(1 + sn)$ for some $C, A > 0$ (Γ being the Γ -function). Note that $s = 0$ means that the series \hat{f} is convergent with sum equal to f .

Lemma 1.1.2. *A function f is asymptotic of Gevrey order $s = \frac{1}{k}$ to 0 on S , if and only if, on every $S' \subset\subset S$, $|f(x)| \leq C e^{-\frac{B}{|x|^k}}$ for some $B, C > 0$.*

Lemma 1.1.3 (Borel, Ritt, Gevrey). *If the growth of the coefficients of $\hat{f}(x) = \sum_{k=0}^{+\infty} a_k x^k$ is bounded by $|a_n| \leq CA^n \Gamma(1 + sn)$ for some $s \geq 0$, then on any open sector S of opening $\leq s\pi$ there exists an analytic function f asymptotic of Gevrey order s to \hat{f} .*

In fact, there are infinitely many such functions f : assuming for simplicity that $S = \{|\arg x| < \frac{s\pi}{2}\}$, one can freely add any multiple of the function $e^{-\frac{B}{x^k}}$, $s = \frac{1}{k}$, $B > 0$, which is asymptotic of Gevrey order s to 0 on the sector. On the other hand:

Lemma 1.1.4 (Watson). *If S is a closed sector of opening $\geq s\pi$, then any analytic function f on S asymptotic of Gevrey order s to $\hat{f} = 0$ is null.*

This is a consequence of the Phragmén–Lindelöf theorem.

1.1.2. Borel summability

The *Borel method of summation of (1-summable) divergent series* is the following. Suppose that the coefficients of a formal power series $\hat{y}(x) = \sum_{l=1}^{+\infty} y_l x^l$ have at most factorial growth: $|y_l| \leq CA^l l!$ for some $C, A > 0$. Using the Euler formula for the Γ -function: $\Gamma(l) = \int_0^{+\infty} z^{l-1} e^{-z} dz$, which is equal to $(l-1)!$ if $l \in \mathbb{N}^*$, one can formally rewrite the series as

$$\hat{y}(x) = \sum_{y=1}^{\infty} y_l x^l = \sum_{l=1}^{\infty} \frac{y_l}{\Gamma(l)} \int_0^{+\infty} \xi^{l-1} e^{-\frac{\xi}{x}} d\xi = \int_0^{+\infty} \widehat{\mathcal{B}}[\hat{y}](\xi) \cdot e^{-\frac{\xi}{x}} d\xi.$$

where

$$\widehat{\mathcal{B}}[\hat{y}](\xi) = \sum_l \frac{y_l}{\Gamma(l)} \xi^{l-1}, \quad (1.1.1)$$

is the *formal Borel transform* of \hat{y} , which is convergent on a neighborhood of $\xi = 0$. Let ϕ be the sum of $\widehat{\mathcal{B}}[\hat{y}]$ and assume that it extends analytically on a half-line $e^{i\alpha}\mathbb{R}^+$, with at most exponential growth at infinity: $|\phi(x)| \leq C e^{B|\xi|}$, $\xi \in e^{i\alpha}\mathbb{R}^+$, for some

$C, B > 0$. Then the *Laplace integral*

$$\mathcal{L}_\alpha[\phi](x) = \int_0^{+\infty e^{i\alpha}} \phi(\xi) e^{-\frac{\xi}{x}} d\xi, \quad (1.1.2)$$

is convergent for x in an open disc of diameter $\frac{1}{B}$ attached to 0 in the direction α and extends to 0, defining there the *Borel sum* of $\hat{y}(x)$. A series $\hat{y}[x]$ is *1-summable* if its Borel sum exists in all but finitely many directions $0 \leq \alpha < 2\pi$. When varying continuously the direction in which the series is summable, the Borel sums are analytic extensions one of the other, yielding a function defined on a sector of opening $> \pi$.

Let us remark that $\hat{y}[x]$ is convergent if and only if it is Borel summable in all directions. This means that the Borel sums of divergent series can only exist on sectors. This is also known as the Stokes phenomenon.

Lemma 1.1.5. *The Borel sum of a 1-summable formal series $\hat{y}(x)$ is asymptotic to $\hat{y}(x)$ of Gevrey order 1 on its sector of definition.*

An important propriety of the Borel summation is that it preserves differential relations, hence if $\hat{y}(x)$ is a formal solution to some analytic differential equation, then so are its Borel sums.

Example 1.1.6. Perhaps the most simple example of a divergent series is the Euler series $\hat{y}(x) = \sum_{l=1}^{+\infty} (l-1)!x^l$, a formal solution of the equation

$$x^2 \frac{dy}{dx} = y - x.$$

Its formal Borel transform is $\widehat{\mathcal{B}}[\hat{y}](\xi) = \frac{1}{1-\xi}$, hence \hat{y} is Borel summable in all directions but \mathbb{R}^+ . This means that the Borel sum of \hat{y} is defined on the open ramified sector $S = \{\arg x \in (-\frac{\pi}{2}, \frac{5\pi}{2})\} \cup \{0\}$.

If f is an analytic function on an open sector S of opening $> \pi$ bisected by $e^{i\alpha}\mathbb{R}^+$ which is uniformly $O(x^\lambda)$, $\lambda > 0$, at 0 on any subsector $S' \subset\subset S$, then its *analytic Borel transformation in direction α* is well defined by

$$\mathcal{B}_\alpha[f](\xi) = \frac{1}{2\pi i} V.P. \int_\gamma y(x) e^{\frac{\xi}{x}} \frac{dx}{x^2} = \frac{1}{2\pi i} \int_{\gamma'} y(x) e^{\frac{\xi}{x}} \frac{dx}{x^2}, \quad \text{for } \xi \in e^{i\alpha}\mathbb{R}^+,$$

where the first integral is defined as the ‘‘Cauchy principal value’’ (*V.P.*) of the integral over a circle $\gamma = \text{Re} \frac{e^{i\alpha}}{x} = A$ for some $A > 0$, while the second integral, over a path γ' as in Figure 1.1, is absolutely convergent.

In particular, for $\lambda > 0$

$$\mathcal{B}_\alpha[x^\lambda](\xi) = \frac{\xi^{\lambda-1}}{\Gamma(\lambda)}. \quad (1.1.3)$$

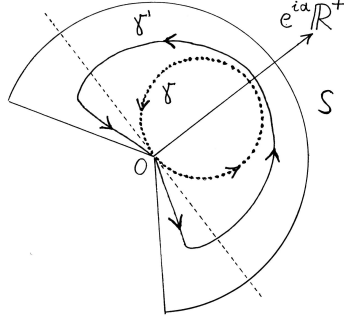

FIGURE 1.1. Integration paths of the Borel transformation in direction α .

Proposition 1.1.7.

- (i) $\mathcal{L}_\alpha[\mathcal{B}_\alpha[f]] = f$, and $\mathcal{B}_\alpha[\mathcal{L}_\alpha[\phi]] = \phi$,
whenever the respective transformations $\mathcal{B}_\alpha[f]$ and $\mathcal{L}_\alpha[\phi]$ are defined.
- (ii) $\mathcal{B}_\alpha[fg] = \mathcal{B}_\alpha[f] * \mathcal{B}_\alpha[g]$, where $[\phi * \psi](\xi) = \int_0^\xi \phi(\xi - s)\psi(s) ds$,
 $\mathcal{B}_\alpha[x^2 \frac{df}{dx}] = \xi \cdot \mathcal{B}_\alpha[f]$.

1.1.3. k -summability

The k -summability is a natural generalization of 1-summability.

Definition 1.1.8. Let $k > 0$. An analytic function f on a closed sector of opening $\geq \frac{\pi}{k}$, bisected by $e^{i\alpha}\mathbb{R}$, that is asymptotic of Gevrey order $\frac{1}{k}$ to a formal series \hat{f} is called a k -sum of \hat{f} in direction α . It is unique by the Watson's lemma (Lemma 1.1.4). A series \hat{f} is k -summable if it has a k -sum in all but finitely many directions.

Hence k -summability is just 1-summability in $z = x^k$. Let ρ_k be the ramification map $x \mapsto x^{\frac{1}{k}}$. The k -sum of some \hat{f} in a direction α can be obtained by the Borel-Laplace summation method as

$$\mathcal{L}_\alpha \left[\widehat{\mathcal{B}_\alpha[\hat{f} \circ \rho_k]} \right] \circ \rho_k^{-1},$$

where $\hat{f} \circ \rho_k$ is a fractional power series whose formal Borel transformation $\widehat{\mathcal{B}_\alpha[\hat{f} \circ \rho_k]}$ is well defined by (1.1.1) on the interior of some sector bisected by $e^{i\alpha}\mathbb{R}^+$.

Example 1.1.9. Let us consider the following vector field in \mathbb{C}^{m+1} with a *codimension k saddle-node singularity*

$$\dot{x} = x^{k+1}, \quad \dot{y} = My + f(x, y), \quad (x, y) \in \mathbb{C} \times \mathbb{C}^m, \quad (1.1.4)$$

where M is an invertible $m \times m$ -matrix and $f(x, y) = O(x) + O(\|y\|^2)$ is a germ of analytic vector function. It possesses a unique formal center manifold given by a

formal solution $\hat{y}(x)$ of the system

$$x^{k+1} \frac{dy}{dx} = M y + f(x, y), \quad (x, y) \in \mathbb{C} \times \mathbb{C}^m. \quad (1.1.5)$$

This formal solution is k -summable in every direction α with $e^{ik\alpha}\mathbb{R}^+ \cap \text{Spec } M = \emptyset$, providing *sectoral center manifolds* on some sectors of opening $> \frac{\pi}{k}$.

In Chapter 3, we will study the unfolding of such sectoral center manifolds in a parametric family of complex vector fields unfolding the singularity for $k = 1$.

1.2. POINCARÉ–DULAC THEORY OF VECTOR FIELDS

A germ of a holomorphic vector field on a neighborhood of $0 \in \mathbb{C}^m$, with a singularity at 0, is written as

$$\dot{u} = F(u), \quad \text{or} \quad F_1(u) \frac{\partial}{\partial u_1} + \dots + F_m(u) \frac{\partial}{\partial u_m}, \quad u \in (\mathbb{C}^m, 0), \quad (1.2.1)$$

with $F = (F_1, \dots, F_m) : (\mathbb{C}^m, 0) \rightarrow (\mathbb{C}^m, 0)$. Two such germs F, F' are *analytically* (resp. *formally*) *equivalent*, if there exist an invertible analytic (resp. formal) map $H : (\mathbb{C}^m, 0) \rightarrow (\mathbb{C}^m, 0)$ such that

$$\left(\frac{\partial H}{\partial u} \right) (u) \cdot F(u) = F'(H(u)).$$

Definition 1.2.1. Let $A = \left(\frac{\partial F}{\partial u} \right) (0)$ be the linearization matrix of a vector field (1.2.1), and let $\lambda_1, \dots, \lambda_m$ be its eigenvalues (with possible repetitions). It has a *resonance* if for some λ_i there exists a tuple of non-negative integers $\mathbf{k} = (k_1, \dots, k_m) \in \mathbb{N}^m$ such that

$$\lambda_i = k_1 \lambda_1 + \dots + k_m \lambda_m, \quad (1.2.2)$$

with $|\mathbf{k}| = k_1 + \dots + k_m \geq 2$, or $|\mathbf{k}| = 1$ and $k_i = 0$. A *resonant monomial* corresponding to such a resonance is a monomial vector field $u_1^{k_1} \dots u_m^{k_m} \frac{\partial}{\partial u_i}$.

Theorem 1.2.2 (Poincaré, Dulac). *A germ of a vector field $F(u) = Au + \dots$ is formally equivalent to a vector field $F'(u) = Ju + \dots$ with J the Jordan normal form of A and with only resonant monomials in the non-linear part.*

More information on this subject can be found in [IY].

1.3. ANALYTIC CLASSIFICATION OF SINGULARITIES OF LINEAR DIFFERENTIAL SYSTEMS

In this section we summarize some classical results on local analytic classification of linear differential systems near a singular point, which we place at the origin of the complex plane. Such a system can be written as

$$x^{k+1} \frac{dy}{dx} = A(x)y, \quad x \in (\mathbb{C}, 0), \quad y \in \mathbb{C}^n, \quad (1.3.1)$$

with $A(x)$ a matrix of germs of holomorphic functions at the origin, $A(0) \neq 0$. The non-negative integer k is called the *Poincaré rank* of the singularity.

A *fundamental matrix solution* of (1.3.1) is a matrix function $\Phi(x)$ whose columns form a local basis of solutions of the system near some point $x_0 \neq 0$. The analytic continuation of Φ along a counterclockwise loop around zero $t \mapsto e^{2\pi it}x_0$, $t \in [0, 1]$, defines another fundamental matrix solution, which we denote $\Phi(e^{2\pi i}x)$. It is related to the original one by a constant invertible matrix M , called the *monodromy matrix* of Φ :

$$\Phi(e^{2\pi i}x) = \Phi(x)M.$$

The conjugacy class of the monodromy matrix is an invariant independent of the choice of fundamental matrix solution.

In order to understand the behavior of the solutions as $x \rightarrow 0$, one investigates invertible linear transformations $y = T(x)u$ which bring the system (1.3.1) to another system,

$$x^{k+1} \frac{du}{dx} = B(x)u, \quad \text{with } B = T^{-1}AT - x^{k+1} \frac{dT}{dx}, \quad (1.3.2)$$

which one would like to be as simple as possible.

Definition 1.3.1. One says that the two systems (1.3.1) and (1.3.2) are: *analytically equivalent* (resp. *meromorphically equivalent*) if $T(x)$ is analytic and analytically invertible (resp. meromorphic and meromorphically invertible) near the origin; and one calls them *formally equivalent* (resp. *formally meromorphically equivalent*) if $T(x) = \sum_{l=0}^{+\infty} T_l x^l$ is a formal transformation with T_0 invertible (resp. $T(x) = \sum_{l \geq l_0}^{+\infty} T_l x^l$, $l_0 \in \mathbb{Z}$, is formally meromorphically invertible).

Let us remark that analytic and formal transformations preserve the Poincaré rank, but meromorphic and formal meromorphic transformations may change it. Here we are interested in formal / analytic equivalence of singularities.

Formal classification of singularities of linear systems (1.3.1) can be reduced to formal classification of the associated vector fields

$$\dot{x} = x^{k+1}, \quad \dot{y} = A(x)y. \quad (1.3.3)$$

Indeed, the normalizing transformations provided by the Poincaré–Dulac theory can be constructed so that they preserve the x -coordinate and are linear in y -coordinates. The only resonant monomials in such a vector field are $x^l y_j \frac{\partial}{\partial y_i}$, $l \in \mathbb{N}$, $i \neq j$, which may appear when the eigenvalues $\lambda_1^{(0)}, \dots, \lambda_n^{(0)}$ of $A(0)$ satisfy a relation

$$\lambda_i^{(0)} = \lambda_j^{(0)} + l \cdot \delta, \quad \delta = \begin{cases} 1, & \text{if } k = 0, \\ 0, & \text{if } k \geq 1. \end{cases}.$$

Definition 1.3.2. The singularity is:

- *Fuchsian*, if $k = 0$. A Fuchsian singularity is called *non-resonant* if no two eigenvalues of the leading matrix $A(0)$ differ by an integer.
- *regular*, if the solutions have a moderate growth (i.e. at most polynomial in $\frac{1}{|x|}$) in any sector at the origin.
- *irregular*, if it is not regular (necessarily $k > 0$). An irregular singularity is called *non-resonant* if the eigenvalues of the leading matrix $A(0)$ are distinct.

Lemma 1.3.3 (Sauvage). *A singularity of linear system is regular if and only if it is meromorphically equivalent to a Fuchsian singularity. In fact, it is meromorphically equivalent to any singularity $x \frac{dy}{dx} = Ay$ with a constant coefficient matrix A whose exponential $e^{2\pi i A}$ belongs to the conjugacy class of the monodromy matrix.*

Proposition 1.3.4. (i) *Formal (meromorphic) transformations between regular singularities are convergent.*

(ii) *A Fuchsian singularity (1.3.1), whose leading matrix $A(0)$ has eigenvalues $\lambda_1^{(0)}, \dots, \lambda_n^{(0)}$, is analytically equivalent to a system*

$$x \frac{dy_i}{dx} = \sum_{j=1}^n b_{ij}(x) y_j,$$

$b_{ij}(x) = \sum_{l=0}^{+\infty} b_{ij}^{(l)} x^l$, where $b_{ii}^{(0)} = \lambda_i^{(0)}$ and $b_{ij}^{(l)} = 0$ unless there is a resonance $\lambda_i^{(0)} - \lambda_j^{(0)} = l$. In particular, one can order the eigenvalues in such a way that the matrix $B(x) = (b_{ij}(x))$ is upper-triangular. This system possesses a fundamental matrix solution $\Phi(x) = x^\Lambda x^N$, where $\Lambda = \text{Diag}(\lambda_1^{(0)}, \dots, \lambda_n^{(0)})$ and $N = B(1) - \Lambda$ is nilpotent.

It follows that two non-resonant Fuchsian singularities are analytically equivalent if and only if their leading matrices have the same eigenvalues.

For irregular singularities, the analytic classification is finer than the formal one due to the divergence of the formal transformations (the Stokes phenomenon). A complete formal and analytic classification of irregular singularities can be found for example in [BJL2], [Ba], [BV], [MR3].

1.3.1. *Non-resonant irregular singularities.*

It follows from the Poincaré–Dulac theorem that a non-resonant irregular singularity of a linear system is formally equivalent to a singularity of a diagonal system. But one says more:

Proposition 1.3.5. *Let a singularity (1.3.1) be non-resonant irregular of Poincaré rank $k \geq 1$, and let*

$$\lambda_i(x) = \lambda_i^{(0)} + x\lambda_i^{(1)} + \dots + x^k\lambda_i^{(k)}, \quad i = 1, \dots, n,$$

be the eigenvalues of $A(x)$ modulo $O(x^{k+1})$. The singularity (1.3.1) is formally equivalent to its formal normal form

$$x^{k+1} \frac{du}{dx} = \Lambda(x)u, \quad \Lambda(x) = \text{Diag}(\lambda_1(x), \dots, \lambda_n(x)), \quad (1.3.4)$$

by means of a k -summable formal transformation $y = \hat{T}(x)u$, unique up to multiplication by a constant diagonal matrix on the right. Its directions of non-summability are those α for which $\lambda_i^{(0)} - \lambda_j^{(0)} \in e^{ik\alpha}\mathbb{R}^+$ for some pair $i \neq j$.

Remark 1.3.6. The proof of this proposition can be reduced to a particular case of Example 1.1.9. The general idea is the following: Assuming that $A(0) = \Lambda(0)$, one can decompose $T(x) = (t_{ij}(x))$ as $T(x) = (I + U(x)) \cdot \text{Diag}(t_{11}(x), \dots, t_{nn}(x))$, where U has only zeros on the diagonal, t_{ii} are analytic functions of U , and the off-diagonal terms u_{ij} of U satisfy a system of Riccati equations of the form

$$x^{k+1} \frac{du_{ij}}{dx} = (\lambda_i - \lambda_j)u_{ij} + \dots,$$

which then possesses a unique k -summable formal solution. We will use the same idea in Theorem 3.2.7 to construct “sectoral” normalizing transformations for parametric families of linear systems unfolding a non-resonant irregular singularity of Poincaré rank $k = 1$.

The diagonal system (1.3.4) has a diagonal fundamental matrix solution

$$\Phi(x) = \text{Diag}(\phi_1, \dots, \phi_n), \quad \phi_j = e^{\int \frac{\lambda_j(x)}{x^{k+1}} dx}. \quad (1.3.5)$$

For each pair $i \neq j$, the $2k$ rays where $\text{Re} \frac{\lambda_i^{(0)} - \lambda_j^{(0)}}{k x^k} = 0$ are called *separation rays*. On one side of such a ray, the quotient function $\frac{\phi_i}{\phi_j}$ is flat (asymptotic to 0) of Gevrey order k , and it is vertical on the other side. The separation rays allow determining the maximal size of sectors on which the Borel sums of the formal normalizing transformation exist.

Theorem 1.3.7 (Sibuya). *Let $\hat{T}(x)$ be the formal transformation of Proposition 1.3.5. Then on any sector that contains exactly one separation ray for each pair $i \neq j$, there*

exists a unique normalizing sectorial transformation asymptotic to $\hat{T}(x)$, that brings the system (1.3.1) to (1.3.4).

If T_α, T_β are two normalizing transformations defined on two adjacent sectors S_α, S_β and asymptotic to \hat{T} , then $T_\beta^{-1}T_\alpha$ is an *automorphism* of the system (1.3.4) on the intersection $S_\alpha \cap S_\beta$, asymptotic to the identity matrix. Let Φ_α, Φ_β be restrictions on S_α, S_β of the fundamental matrix solution $\Phi(x)$ (1.3.5) of (1.3.4), then

$$T_\beta(x)^{-1}T_\alpha(x) = \Phi_\beta(x)C_{\beta\alpha}\Phi_\alpha(x)^{-1} \quad (1.3.6)$$

for a constant matrix $C_{\beta\alpha} \in \text{GL}_n(\mathbb{C})$, called a *Stokes matrix*. It follows, that at least one of the entries of $C_{\beta\alpha}$ at each two symmetric positions $(\)_{ij}, (\)_{ji}$ must be null for every $i \neq j$, and that its diagonal entries must be equal to 1; hence $C_{\beta\alpha}$ is a *unipotent* matrix (i.e. $C_{\beta\alpha} - I$ is nilpotent).

Let us now fix sectors S_1, \dots, S_{2k} of the Sibuya theorem, covering a neighborhood of the origin in clockwise order, together with unique normalizing transformations T_1, \dots, T_{2k} asymptotic to \hat{T} , and diagonal fundamental matrix solutions Φ_1, \dots, Φ_{2k} (1.3.5). This determines a set of Stokes matrices $C_{12}, C_{23}, \dots, C_{2k,1}$ (1.3.6) called *Stokes data*. Let us remark that one can always choose the covering sectors so that $C_{m,m+1}$ is upper-triangular if m is odd and lower-triangular if m is even. The product $C_{12}C_{23} \dots C_{2k,1}$ is equal to the monodromy matrix of the fundamental matrix solution $T_1\Phi_1$ of the original system (1.3.1).

Theorem 1.3.8 (Birkhoff). *Two formally equivalent germs of systems (1.3.1) with a non-resonant irregular singularity at the origin are analytically equivalent if and only if their Stokes data are conjugate by a same invertible diagonal matrix. Any Stokes data are realizable by a system (1.3.1) formally equivalent to the system (1.3.4).*

This can also be naturally formulated in a more general way in terms of a non-abelian cohomology of a *Stokes sheaf* (i.e. non-abelian sheaf of sectorial automorphisms of (1.3.4) asymptotic to the identity), see e.g. [Ma1], [BV].

Chapter 2

ANALYTIC CLASSIFICATION OF FAMILIES OF LINEAR DIFFERENTIAL SYSTEMS UNFOLDING A RESONANT IRREGULAR SINGULARITY

Abstract. We give a complete classification of analytic equivalence of germs of parametric families of systems of complex linear differential equations unfolding a generic resonant singularity of Poincaré rank 1 in dimension $n = 2$ whose leading matrix is a Jordan bloc. The moduli space of analytic equivalence classes is described in terms of a tuple of formal invariants and a single analytic invariant obtained from the trace of monodromy. Moreover, analytic normal forms are given for all such singularities.

2.1. INTRODUCTION

A system of meromorphic linear differential equations with a singularity at the origin can be written locally as $\Delta_0(z)y = 0$, with

$$\Delta_0(z) = z^{k+1} \frac{d}{dz} - A_0(z), \quad z \in (\mathbb{C}, 0), \quad (2.1.1)$$

$y(z) \in \mathbb{C}^n$, where A_0 is an analytic matrix in a neighborhood of 0 with $A_0(0) \neq 0$, and k is a non-negative integer, called the Poincaré rank. Its unfolding is a germ of a parametric family of systems $\Delta(z, m)y = 0$, with

$$\Delta(z, m) = h(z, m) \frac{d}{dz} - A(z, m), \quad (z, m) \in (\mathbb{C} \times \mathbb{C}^l, 0), \quad (2.1.2)$$

$y(z, m) \in \mathbb{C}^n$, where the scalar function h and the $n \times n$ -matrix function A depend analytically on both the variable z and the parameter m . Two families of linear systems (2.1.2) depending on the same parameter m are *analytically equivalent* if there exists an invertible analytic linear gauge transformation bringing solutions of the first system to solutions of the second.

The analytic classification of singularities of single systems (2.1.1) is well known: it is given by a formal normal form and by so called Stokes operators. *Regular*

singularities are analytically equivalent if and only if they are equivalent by means of a formal power series transformation. In contrast, for *irregular* singularities such formal transformations are generally divergent. However they are asymptotic to true analytic transformations on certain sectors, whose general mismatch is known as the *Stokes phenomenon*.

Investigating parametric unfoldings of singularities has two essential goals: to explain the Stokes phenomenon through confluence, and to provide analytic normal forms for germs of parametric systems. It has been conjectured independently by V.I. Arnold, A. Bolibruch and J.-P. Ramis, that Stokes matrices of the limit problem can be obtained as limits of transition matrices between certain canonical solution bases at the regular singular points of a generically perturbed system; this was later proved by A. Glutsyuk for non-resonant [G1] and certain resonant singularities [G3]. But Glutsyuk’s approach covers only a sector in the parameter space, on which the deformation is generic: all the singularities are supposed to be simple and non-resonant. A complete analytic classification of germs of parametric families of systems unfolding a non-resonant irregular singularity was obtained recently by J. Hurtubise, C. Lambert and C. Rousseau [LR], [HLR].

This article provides the first results on analytic classification of parametric families unfolding a *resonant* irregular singularity. We consider germs of parametric families of systems $\Delta(z, m)$ in a neighborhood of $(z, m) = 0$ unfolding a system $\Delta_0(z) = \Delta(z, 0)$,

$$\Delta_0(z) = z^2 \frac{d}{dz} - A_0(z), \quad \text{with} \quad A_0(0) = \begin{pmatrix} \lambda_0^{(0)} & 1 \\ 0 & \lambda_0^{(0)} \end{pmatrix}, \quad (2.1.3)$$

that has a resonant singularity of Poincaré rank 1 at the origin, and satisfies a generic condition that the element $a_{21}^{(1)}$ on the position $_{2,1}$ of the matrix $\frac{d}{dz} A_0(0)$ is non-zero:

$$a_{21}^{(1)} = -\frac{d}{dz} \det(A_0(z) - \lambda_0^{(0)} I)|_{z=0} \neq 0. \quad (2.1.4)$$

An analytic classification of germs of such single systems $\Delta_0(z)$ was originally given in [JLP2].

In Section 2.2.1 we give a complete analytic classification of all germs of parametric systems $\Delta(z, m)$ unfolding such a $\Delta_0(z)$ (Theorem I), and an explicit analytic normal form, i.e. a universal unfolding for any system Δ_0 (2.1.3) satisfying (2.1.4) (Theorem II). No restriction is imposed on the nature of the analytic deformation $\Delta(z, m)$ of $\Delta_0(z)$ or on the complex parameter $m \in (\mathbb{C}^l, 0)$.

Section 2.2.2 is devoted to a study of the Stokes phenomena in parametric families. We construct “sectorial” transformations in the (x, m) -space between formally

equivalent families (Theorem III), and explain the phenomena of confluence of singularities and of change of order of summability.

2.2. STATEMENT OF RESULTS

Definition 2.2.1. By a *parametric system* we shall mean a germ (2.1.2) unfolding (2.1.3) satisfying (2.1.4).

Definition 2.2.2. Let $\Delta(z, m)y = 0$ be a parametric family of linear systems (2.1.2) and $y(z, m) = T(z, m)u(z, m)$ be a linear transformation of the dependent variable. Let us define a transformed system

$$T^*\Delta := h \frac{d}{dz} - \left[T^{-1}AT - hT^{-1} \frac{dT}{dz} \right], \quad (2.2.1)$$

satisfying $(T^*\Delta)u = 0$ if and only if $\Delta y = 0$.

We say that two germs of parametric systems $\Delta(z, m) = h(z, m) \frac{d}{dz} - A(z, m)$, $\Delta'(z, m) = h'(z, m) \frac{d}{dz} - A'(z, m)$, depending on the same parameter m are *analytically equivalent*, if there exists an invertible linear transformation $T(z, m) \in \text{GL}_n(\mathbb{C})$, depending analytically on (z, m) , such that $h'^{-1} \cdot \Delta' = h^{-1} \cdot T^*\Delta$.

Definition 2.2.3 (The invariants).

- (i) After multiplying by a non-vanishing germ of scalar function, any parametric system $\Delta(z, m)$ unfolding (2.1.3) can be written in a unique way with

$$h(z, m) = z^2 + h^{(1)}(m)z + h^{(0)}(m). \quad (2.2.2)$$

We shall suppose that h is in this form from now on. Then we define invariant polynomials $\lambda(z, m)$, $\alpha(z, m)$ by

$$\begin{aligned} \lambda(z, m) &= \frac{1}{2} \text{tr} A(z, m) \pmod{h(z, m)} \\ &= \lambda^{(1)}(m)z + \lambda^{(0)}(m), \\ \alpha(z, m) &= -\det(A(z, m) - \lambda(z, m)I) \pmod{h(z, m)} \\ &= \alpha^{(1)}(m)z + \alpha^{(0)}(m). \end{aligned} \quad (2.2.3)$$

We call the triple $h(z, m)$, $\lambda(z, m)$, $\alpha(z, m)$ *formal invariants* of Δ .

- (ii) We define an *analytic invariant* $\gamma(m)$ by

$$\gamma(m) = e^{-2\pi\lambda^{(1)}(m)} \cdot \text{tr} M(m), \quad (2.2.4)$$

where for each fixed value of the parameter m , $M(m)$ is a monodromy matrix of some fundamental solution $\Phi(z, m)$ of the system $\Delta(\cdot, m)$ around the two zeros of $h(z, m)$ in the positive direction:

$$\Phi(e^{2\pi i}z_0, m) = \Phi(z_0, m)M(m).$$

The value of $\gamma(m)$ is independent of the choice of the fundamental solution $\Phi(z, m)$ or of the point z_0 , and can be calculated for each value of m independently.

Proposition 2.2.4. $h(z, m)$, $\lambda(z, m)$, $\alpha(z, m)$ and $\gamma(m)$ are all analytic in m and invariant under analytical equivalence of systems. The genericity condition (2.1.4) means that $\alpha^{(1)}(0) \neq 0$.

PROOF. Elementary. □

Remark 2.2.5. Let

$$\Delta_m := \Delta(\cdot, m)$$

denote the restriction of Δ to a fixed parameter m . The corresponding restriction of the invariants $h(x, m)$, $\lambda(x, m)$, $\alpha(x, m)$, determine for almost all values of m a complete set of formal invariants of Δ_m , i.e. invariants with respect to formal power series transformations $\hat{T}_m(z) = \sum_{l=0}^{\infty} T_m^{(l)}(z - z_i)^l$. (cf. [Ba],[IY],[Wa]).

- (a) If $h(z, m)$ has a double zero at z_1 and $A(z_1, m)$ has a double eigenvalue, i.e. $\alpha(z_1, m) = 0$, then Δ_m has a *resonant irregular singularity*¹, and the values $\lambda(z_1, m)$, $\lambda^{(1)}(m)$, $\alpha^{(1)}(m)$ constitute a complete set of its formal invariants. [JLP2]
- (b) If $h(z, m)$ has a double zero at z_1 and $\alpha(z_1, m) \neq 0$, then Δ_m has a *nonresonant irregular singularity*¹, and $\lambda(z_1, m)$, $\lambda^{(1)}(m)$, $\alpha(z_1, m)$, $\alpha^{(1)}(m)$ constitute a complete set of its formal invariants. [JLP1]
- (c) If $h(z, m)$ has two different zeros $z_1 \neq z_2$, then the system Δ_m has a *Fuchsian singularity*¹, at each of them. Supposing that Δ_m is non-resonant at z_i , i.e. that $2\frac{\sqrt{\alpha(z_i, m)}}{z_i - z_j} \notin \mathbb{Z}$ ($j = 3 - i$), then the values of $\frac{\lambda(z_i, m)}{z_i - z_j}$ and $\frac{\alpha(z_i, m)}{(z_i - z_j)^2}$ constitute a complete set of formal invariants for the germ of Δ_m at z_i . [IY],[Wa]

2.2.1. Analytic theory

Theorem I (Analytic classification).

- (a) Two germs of parametric systems $\Delta(z, m)$, $\Delta'(z, m)$ are analytically equivalent if and only if their invariants h , λ , α , γ are the same:

$$\begin{aligned} h(z, m) &= h'(z, m), & \lambda(z, m) &= \lambda'(z, m), \\ \alpha(z, m) &= \alpha'(z, m), & \gamma(m) &= \gamma'(m). \end{aligned}$$

¹A singularity of a system $\Delta_m(z) = h_m(z)\frac{d}{dz} - A_m(z)$ is *Fuchsian* if it is a simple pole of $\frac{A_m(z)}{h_m(z)}$; it is *regular* if the growth of solutions is power-like, or equivalently, if it is meromorphically equivalent to a simple pole; else it is *irregular*. A Fuchsian singularity at z_1 is *non-resonant* if no two eigenvalues of the residue matrix of $\frac{A_m(z)}{h_m(z)}$ at z_1 differ by an integer. An irregular singularity at z_1 is *non-resonant* if the eigenvalues of $A_m(z_1)$ are distinct.

(b) Any four germs of analytic functions $h(z, m)$, $\lambda(z, m)$, $\alpha(z, m)$, $\gamma(m)$ with $h(z, 0) = z^2$, $\alpha^{(0)}(0) = 0$ and $\alpha^{(1)}(0) \neq 0$ are realizable as invariants of some parametric system $\Delta(z, m)$.

Corollary 2.2.6. *Two germs of parametric systems $\Delta(z, m)$, $\Delta'(z, m)$ are analytically equivalent if and only if there exists a small neighborhood $Z \times M$ of 0 in $\mathbb{C} \times \mathbb{C}^l$ such that for each $m \in M$ the restricted systems $\Delta_m(z)$, $\Delta'_m(z)$ are analytically equivalent on Z .*

The Theorem II provides a normal form for any germ of parametric system unfolding Δ_0 .

Theorem II (Universal unfolding). *Let $\Delta(z, m)$ be a germ of parametric system and $h(z, m)$, $\lambda(z, m)$, $\alpha(z, m)$, $\gamma(m)$ its invariants.*

(i) *If $\gamma(0) \neq 2$, then $\Delta(z, m)$ is analytically equivalent to a germ at 0 of parametric system $\tilde{\Delta}(h(z, m), \lambda(z, m), \alpha(z, m), q(m))$ given by*

$$\tilde{\Delta}(h, \lambda, \alpha, q) = h(z) \frac{d}{dz} - \begin{pmatrix} \lambda(z) & 1 \\ \alpha(z) + qh(z) & \lambda(z) \end{pmatrix}, \quad (2.2.5)$$

where $q(m)$ is an analytic germ such that

$$\gamma(m) = -2 \cos \pi \sqrt{1 + 4q(m)}. \quad (2.2.6)$$

Let us remark that $\tilde{\Delta}$ is meromorphic in $z \in \mathbb{CP}^1$ and has a regular singular point at infinity.

(ii) *If $\gamma(0) \neq -2$, then $\Delta(z, m)$ is analytically equivalent to a germ at 0 of parametric system $\tilde{\Delta}'(h(z, m), \lambda(z, m), \alpha(z, m), b(m))$ given by*

$$\tilde{\Delta}'(h, \lambda, \alpha, b) = h(z) \frac{d}{dz} - \begin{pmatrix} \lambda(z) & 1 + bz \\ \beta(z) & \lambda(z) \end{pmatrix}, \quad (2.2.7)$$

with

$$\beta(z) = \alpha^{(0)} + bh^{(0)}\beta^{(1)} + \beta^{(1)}z, \quad \beta^{(1)} = \frac{\alpha^{(1)} - b\alpha^{(0)}}{1 - bh^{(1)} + b^2h^{(0)}}, \quad (2.2.8)$$

where $b(m)$ is an analytic germ such that

$$\gamma(m) = 2 \cos 2\pi \sqrt{b(m)\beta^{(1)}(m)}. \quad (2.2.9)$$

Let us remark that $\tilde{\Delta}'$ is meromorphic in $z \in \mathbb{CP}^1$ and has a Fuchsian singular point at infinity. It is in, so called, Birkhoff normal form.²

²V. Kostov [K0] showed that any unfolding of an arbitrary system Δ_0 (2.1.1) in a Birkhoff normal form, whose eigenvalues of $\text{Res}_{z=0} \frac{A_0(z)}{z^2}$ do not differ by a non-zero integer, is analytically equivalent to a parametric system in a Birkhoff normal form. Our result confirms it in the case studied here: $\gamma(0) = -2$ corresponds exactly to systems $\tilde{\Delta}'_0$ violating the condition of Kostov.

2.2.2. Formal theory and a study of confluence

Proposition 2.2.7 (Formal classification). *A germ of parametric system $\Delta(z, m)$ is formally equivalent to its formal normal form*

$$\widehat{\Delta}(z, m) = h(z, m) \frac{d}{dz} - \begin{pmatrix} \lambda(z, m) & 1 \\ \alpha(z, m) & \lambda(z, m) \end{pmatrix}, \quad (2.2.10)$$

by means of a unique formal power series transformation in (x, m)

$$\widehat{T}(x, m) = \sum_{j, |\mathbf{k}|=0}^{+\infty} T^{(j, \mathbf{k})} x^j m^{\mathbf{k}}, \quad m^{\mathbf{k}} = m_1^{k_1} \dots m_l^{k_l}, \quad T^{(0, \mathbf{0})} = I.$$

Generically, this series is divergent in x and m .

In this sense, two parametric systems $\Delta(z, m)$, $\Delta'(z, m)$ are formally equivalent if and only if their formal invariants h , λ , α are the same.

Remark 2.2.8. Let us remark that any linear transformation $T(z, m)$ commutes with scalar matrices

$$T^*(\Delta - \lambda I) = T^* \Delta - \lambda I,$$

i.e. that two systems Δ , Δ' are analytically (resp. formally) equivalent if and only if the systems $\Delta - \lambda I$, $\Delta' - \lambda I$ are. Hence we can restrict ourselves to systems whose formal invariant $\lambda(z, m) = 0$.

Definition 2.2.9 (Reduced invariants $\epsilon(m)$, $\mu(m)$). Let $\Delta(z, m)$ be a parametric system with formal invariants $h(z, m)$, $\lambda(z, m)$, $\alpha(z, m)$. Put

$$x(z, m) = \frac{1}{\alpha^{(1)}} \left(z + \frac{h^{(1)}}{2} \right) \quad \text{and} \quad \epsilon(m) = \left(\frac{1}{\alpha^{(1)}} \right)^2 \left(\left(\frac{h^{(1)}}{2} \right)^2 - h^{(0)} \right), \quad (2.2.11)$$

so that $h(z, m) = (\alpha^{(1)})^2 (x^2 - \epsilon)$. Then in the new coordinate x , after division by $\alpha^{(1)}$, the system $\Delta - \lambda I$ becomes

$$\underline{\Delta}(x, m) = (x^2 - \epsilon) \frac{d}{dx} - \frac{A(z(x, m), m) - \lambda(z(x, m), m) I}{\alpha^{(1)}(m)},$$

with formal invariants

$$\underline{h}(x, m) = x^2 - \epsilon(m), \quad \underline{\lambda}(x, m) = 0, \quad \underline{\alpha}(x, m) = \mu(m) + x,$$

where

$$\mu = \frac{\alpha^{(0)}}{(\alpha^{(1)})^2} - \frac{h^{(1)}}{2\alpha^{(1)}}.$$

The invariants $\epsilon(m)$ and $\mu(m)$ are responsible for two basic qualitative changes of the system:

- $\epsilon(m)$ corresponds to separation of the double singularity ($\epsilon = 0$) into two simple ones ($\epsilon \neq 0$),

- $\mu(m)$ corresponds, when $\epsilon(m) = 0$, to separation of the double eigenvalue ($\mu = 0$) of $A(0, m)$ into two simple ones ($\mu \neq 0$), hence to the disappearance of resonance.

In the rest of this section we will for simplicity assume that $\Delta(x, m) = \underline{\Delta}(x, m)$ is in this *reduced form*, and so is its *formal normal form* of Proposition 2.2.7

$$\widehat{\Delta}(x, m) = (x^2 - \epsilon) \frac{d}{dx} - \begin{pmatrix} 0 & 1 \\ \mu + x & 0 \end{pmatrix}. \quad (2.2.12)$$

Remark 2.2.10 (Sectorial normalization of $\Delta_m(x)$). Let $\Delta(x, m)$ be analytic on a polydisc $X \times M \subseteq \mathbb{C} \times \mathbb{C}^l$, and let $m \in M$ be such that both roots of $h(x, m) = x^2 - \epsilon(m)$ are in X . As before, let $\Delta_m(x)$ denote the restriction of $\Delta(x, m)$ to the fixed value of m . Following Remark 2.2.5, depending on $\epsilon(m)$ and $\mu(m)$ we have the following four possible situations:

- (a) $\epsilon = \mu = 0$: The restricted system Δ_m , which has a *resonant irregular singularity* at the origin, is formally equivalent to $\widehat{\Delta}_m$ by means of a $\frac{1}{2}$ -summable formal power series transformation $\widehat{T}_{O,m}(x)$. In particular, there exists a unique normalizing sectorial transformation $T_{O,m}(x)$, defined on a ramified sector

$$S_{O,m} = \{x \in X \mid |\arg x + \pi| < 2\pi - \eta\}, \quad \text{with } \eta > 0 \text{ arbitrarily small,}$$

which is asymptotic to the formal series $\widehat{T}_{O,m}$.

- (b) $\epsilon = 0, \mu \neq 0$: The restricted system Δ_m , which has a *non-resonant irregular singularity* at the origin, is formally equivalent to $\widehat{\Delta}_m$ by means of a 1-summable formal power series transformation $\widehat{T}_{I,m}(x)$. In particular, there exists a unique pair of normalizing sectorial transformations $T_{I,m}^\pm(x)$, defined on a pair of sectors

$$S_{I,m}^\pm = \{x \in X \mid |\arg x \mp \arg \sqrt{\mu}| < \pi - \eta\}, \quad \text{with } \eta > 0 \text{ arbitrarily small,}$$

which are asymptotic to the formal series $\widehat{T}_{I,m}$.

- (c) $\epsilon \neq 0$: The restricted system has *two Fuchsian singularities* at $x_1 = \sqrt{\epsilon}$ and $x_2 = -\sqrt{\epsilon}$. Supposing that m is such that the singularity at x_i is *non-resonant*, i.e. that $\frac{\sqrt{\mu+x_i}}{x_i} \notin \mathbb{Z}$, then there exists a unique local analytic transformation $T_{i,m}(x)$, defined on a neighborhood $S_{i,m}$ of x_i , such that $T_{i,m}(x_i) = I$ and $T_{i,m}^* \Delta_m = \widehat{\Delta}_m$. One can take

$$S_{i,m} = \{x \in X \mid |\arg x - \arg x_i| < \pi - \eta\}, \quad \text{with } \eta > 0 \text{ arbitrarily small.}$$

- (d) $\epsilon \neq 0$: If a Fuchsian singularity at x_i is *resonant*, i.e. $\pm \frac{\sqrt{\mu+x_i}}{x_i} = k \in \mathbb{N}^*$, then there exists a transformation $T_{i,m}(x) = T'_{i,m}(x) + (x - x_i)^k \log(x - x_i) T''_{i,m}(x)$,

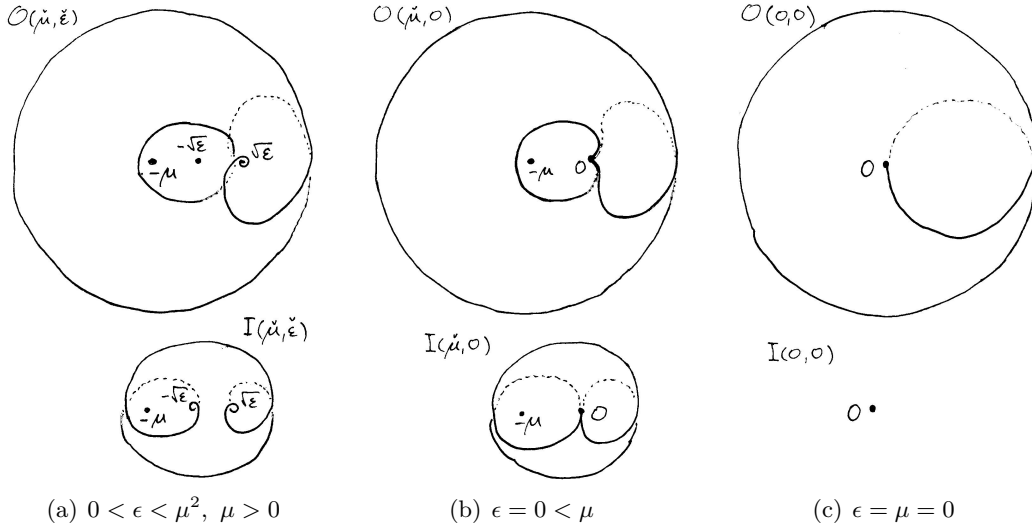

FIGURE 2.1. Examples of the outer and inner domains $O(\epsilon, \mu)$, $I(\epsilon, \mu)$ of Theorem III for selected values of μ, ϵ .

with $T'_{i,m}, T''_{i,m}$ analytic on a neighborhood $S_{i,m}$ of x_i , $T'_{i,m}(x_i) = I$ and $T''_{i,m}$ nilpotent, such that $T_{i,m}^* \Delta_m = \widehat{\Delta}_m$.

The *change of order of summability* of the formal normalizing transformations in between the cases (a) and (b) is a phenomenon that has not been studied previously. In the following Theorem III it is explained by an appearance of a new domain of normalization $I(\mu, \epsilon)$, for $(\mu, \epsilon) \neq (0, 0)$, with a new normalizing transformation T_I corresponding to the case (b), different than the transformation T_O corresponding to the case (a), which persists on a domain $O(\mu, \epsilon)$. These domains I, O , and the normalizing transformations T_I, T_O on them, will be defined for all values of the parameter m taken from a ramified domain covering a full neighborhood of 0 in the parameter space.

Definition 2.2.11 (Analytic functions on parametric domains). Let Ω be a connected (ramified) set in the space $(x, m) \in \mathbb{C} \times \mathbb{C}^l$, corresponding to a parametric family of (ramified) domains

$$\Omega(m) = \{x \mid (x, m) \in \Omega\},$$

in the x -plane depending on a parameter m . We write

$$f \in \mathcal{B}(\Omega) \quad \text{if} \quad \begin{aligned} (i) & \quad f \in \mathcal{C}(\Omega) \cap \mathcal{O}(\text{int } \Omega) \\ (ii) & \quad f(\cdot, m) \in \mathcal{O}(\text{int } \Omega(m)) \quad \text{for each } m. \end{aligned}$$

Theorem III (Sectoral normalization). *Let $\Delta(x, m)$ be a germ of a parametric system, unfolding $\Delta_0(x)$, and let $\epsilon(m), \mu(m)$ be its reduced formal invariants. There*

exist two ramified domains of normalization in the (x, m) -space: an outer domain O and an inner domain I , covering together a full neighborhood of $0 \in \mathbb{C} \times \mathbb{C}^l$, on which exist normalizing gauge transformations $T_O \in \text{GL}_2(\mathcal{B}(O))$, $T_I \in \text{GL}_2(\mathcal{B}(I))$, between the unfolded system and its formal normal form (2.2.12):

$$T_\Omega^* \Delta = \widehat{\Delta}, \quad \Omega = O, I.$$

More precisely, the domains $\Omega = O, I$ can be written as parametric families of ramified domains $\Omega(\mu(m), \epsilon(m))$ in the x -plane, whose shape depends only on the invariants $\epsilon(m), \mu(m)$

$$\Omega = \bigcup_{m \in M} \Omega(\mu(m), \epsilon(m)) \times \{m\},$$

over a ramified domain M covering the parameter space m . See Figure 2.1.

- (a) The outer domain $O(\mu(m), \epsilon(m))$ is doubly attached to $x_1 = \sqrt{\epsilon}$. For $(\mu, \epsilon) = (0, 0)$ it becomes a ramified sector $O(0, 0)$ at the origin of opening $> 2\pi$, in which case $T_O(\cdot, m) = T_{O,m}$ of Remark 2.2.10.
- (b) The inner domain $I(\mu(m), \epsilon(m))$ is ramified and attached to $x_1 = \sqrt{\epsilon}$ and $x_2 = -\sqrt{\epsilon}$. For $\epsilon = 0, \mu(m) \neq 0$, it splits in to a pair of sectors $I^\pm(\mu(m), 0)$ at the origin of opening $> \pi$, in which case $T_I(\cdot, m) = T_{I,m}^\pm$ of Remark 2.2.10. For $(\mu, \epsilon) = (0, 0)$ the domain shrinks to a single point $I(0, 0) = \{0\}$.

The domains O, I are constructed in section 2.3.6.

As a corollary, we obtain the following result on convergence of the normalizing transformations of Remark 2.2.10, (b) $T_{I,m}^\pm$ and (c) $T_{i,m}$ to (a) $T_{O,m}$.

Theorem IV. *Following the notation of Remark 2.2.10.*

- (i) The normalizing transformations $T_{I,m}^+$ (resp. $T_{I,m}^-$) converge to $T_{O,m}$, as $\mu(m) \rightarrow 0$ radially, for each m with $0 < \arg \mu(m) < 2\pi$ (resp. $0 > \arg \mu(m) > -2\pi$). The convergence is uniform on compact sets in $S_{I,m}^+$ (resp. $S_{I,m}^-$).
- (ii) The normalizing transformation $T_{2,m}$, analytic on a neighborhood of $x_2 = -\sqrt{\epsilon(m)}$, converges to $T_{O,m}$, when $\epsilon(m) \rightarrow 0$ radially and $\mu(m) = O(\epsilon(m))$, if $\arg x_2 \in (\frac{\pi}{2}, \frac{3\pi}{2})$, i.e. $|\arg \sqrt{\epsilon(m)}| < \frac{\pi}{2}$. The convergence is uniform on compact sets in $S_{2,m}$.

The second statement was originally established by A. Glutsyuk [G3] in a more general setting.

2.3. PROOFS

Without loss of generality, we can always assume that the parametric system $\Delta(x, m)$ has the reduced form of Definition 2.2.9 with formal invariants equal to

$$h(x, m) = x^2 - \epsilon(m), \quad \lambda(x, m) = 0, \quad \alpha(x, m) = \mu(m) + x. \quad (2.3.1)$$

Our strategy will be the following. In Section 2.3.1 we will bring the system by an analytic gauge transformation to a simple prenormal form and prove Proposition 2.2.7. Theorem II follows from Theorem I (a) by an easy calculation of the invariants of the two families $\tilde{\Delta}, \tilde{\Delta}'$, done in Section 2.3.2. And part (b) of Theorem I is a direct consequence of Theorem II. To prove part (a) of Theorem I, we will first construct the normalizing transformations of Theorem III, together with their natural domains $\Omega = O, I$, and provide a canonical set of fundamental matrix solutions defined on these domains. The analytic equivalence of two parametric systems with the same analytic invariant γ is established after expressing all the connection matrices (Stokes matrices) between the canonic fundamental solutions.

It turns out that it is better to do all this in a new ramified coordinate

$$s = \sqrt{\mu + x}.$$

The lifting to this s -coordinate produces a two-fold symmetry of the systems as well as their normalizing transformations. After establishing the analytic equivalence of the lifted systems in the s -coordinate, one uses this symmetry to push it down to the x -coordinate.

While everything, all the transformations and connection matrices, will depend on the parameter m , we will often drop it from our notation, and think of it as implicitly present; for example, we will sometimes write (μ, ϵ) rather than $(\mu(m), \epsilon(m))$.

2.3.1. Prenormal form.

Proposition 2.3.1 (Prenormal form). *A germ of a parametric system $\Delta(x, m)$, with formal invariants (2.3.1), is analytically equivalent to*

$$\Delta'(x, m) = (x^2 - \epsilon) \frac{d}{dx} - \begin{pmatrix} 0 & 1 \\ \mu + x + (x^2 - \epsilon)r(x, m) & 0 \end{pmatrix}. \quad (2.3.2)$$

PROOF. We will bring the system Δ into the demanded form in four steps.

1) There exists an analytic germ of an invertible matrix $C(m)$, constant in x , such that

$$\Delta_1 =: C^* \Delta = (x^2 - \epsilon) \frac{d}{dx} - A(x, m), \quad \text{with} \quad A(x, m) = \sum_{l=0}^{\infty} A^{(l)} x^l$$

and $A^{(0)} = \begin{pmatrix} 0 & 1 \\ a_{21}^{(0)} & a_{22}^{(0)} \end{pmatrix}$, see [Ar].

2) We look for a transformation in the form of a convergent series

$$T(x, m) = I + \sum_{l=1}^{\infty} T^{(l)}(m) x^l, \quad \text{with} \quad T^{(l)} = \begin{pmatrix} 0 & 0 \\ t_{21}^{(l)} & t_{22}^{(l)} \end{pmatrix},$$

analytic in m , such that $\Delta_2 =: T^* \Delta_1 = (x^2 - \epsilon) \frac{d}{dx} - B(x, m)$,

$$B(x, m) = \sum_{l=0}^{\infty} B^{(l)} x^l, \quad \text{with} \quad B^{(0)} = A^{(0)} \quad \text{and} \quad B^{(l)} = \begin{pmatrix} 0 & 0 \\ b_{21}^{(l)} & b_{22}^{(l)} \end{pmatrix}. \quad (2.3.3)$$

This means that

$$B^{(l)} = [A^{(0)}, T^{(l)}] + A^{(l)} + \sum_{j=1}^{l-1} A^{(j)} T^{(l-j)} - \sum_{j=1}^{l-1} T^{(l-j)} B^{(j)} - (l-1) T^{(l-1)} + \epsilon(l+1) T^{(l+1)},$$

with elements in the first line equal to

$$0 = t_{2,i}^{(l)} + a_{1i}^{(l)} + \sum_{j=1}^{l-1} a_{12}^{(j)} t_{2i}^{(l-j)}, \quad i = 1, 2,$$

giving a recursive formula for the coefficients of T . Knowing that $A(x)$ is convergent, i.e. $|a_{ki}^{(l)}| \leq K^l$ for some $K > 0$, we shall find inductively that $|t_{2,i}^{(l)}| \leq (2K)^l$: indeed, $|t_{2,i}^{(l)}| \leq \sum_{j=1}^l 2^{l-j} K^l \leq 2^l K^l$.

3) Let $b_{22}(x, m) = \sum_{l=0}^{\infty} b_{22}^{(l)} x^l$ (2.3.3), and put $S(x, m) = \begin{pmatrix} 1 & 0 \\ \frac{1}{2} b_{22} & 1 \end{pmatrix}$, then

$$\Delta_3 =: S^* \Delta_2 = (x^2 - \epsilon) \frac{d}{dx} - \begin{pmatrix} \frac{1}{2} b_{22}(x, m) & 1 \\ f(x, m) & \frac{1}{2} b_{22}(x, m) \end{pmatrix},$$

for some $f(x, m)$. By the assumption (2.3.1) we know that we can write $b_{22}(x, m) = (x^2 - \epsilon)g(x, m)$ with an analytic germ g , and that $f(x, m) = \mu + x + (x^2 - \epsilon)r(x, m)$ for some germ r .

4) Finally use $R(x, m) = e^{-\int_0^x \frac{1}{2} g(t, m) dt} I$, to get rid of the diagonal term: $R^* \Delta_3 = \Delta'$ is in the demanded form. \square

PROOF OF PROPOSITION 2.2.7. Let $\Delta(x, m)$ be a germ of parametric system in the prenormal form (2.3.2). We will show that there exists a formal transformation $\hat{T}(x, m)$ in form of a power series in (x, μ, ϵ) whose coefficients depends analytically on m , that brings $\Delta(x, m)$ to the reduced formal normal form $\hat{\Delta}(x, m)$ (2.2.12). We shall be looking for \hat{T} written as

$$\hat{T}(x, m) = a(x, m) I + b(x, m) \begin{pmatrix} 0 & 1 \\ \mu + x & 0 \end{pmatrix} + (x^2 - \epsilon) \begin{pmatrix} 0 & 0 \\ c(x, m) & d(x, m) \end{pmatrix}.$$

We want that $\widehat{\Delta} = \widehat{T}^* \Delta$, which means

$$\left[\begin{pmatrix} 0 & 1 \\ \mu + x & 0 \end{pmatrix}, \begin{pmatrix} 0 & 0 \\ c(x, m) & d(x, m) \end{pmatrix} \right] + \begin{pmatrix} 0 & 0 \\ r(x, m) & 0 \end{pmatrix} \cdot \widehat{T}(x, m) = \frac{d\widehat{T}(x, m)}{dx},$$

where $[\cdot, \cdot]$ stands for the commutator of matrices. This gives a system of equations

$$c = a', \quad (2.3.4)$$

$$d = b', \quad (2.3.5)$$

$$-(\mu + x)d + ar = b + (\mu + x)b' + 2xc + (x^2 - \epsilon)c', \quad (2.3.6)$$

$$-c + br = a' + 2xd + (x^2 - \epsilon)d', \quad (2.3.7)$$

where $'$ stands for the (formal) derivative w.r.t. x . Substituting (2.3.4) and (2.3.5) in (2.3.6) and (2.3.7) gives

$$b + 2(\mu + x)b' = ar - 2xa' - (x^2 - \epsilon)a'', \quad (2.3.8)$$

$$2a' = br - 2xb' - (x^2 - \epsilon)b''. \quad (2.3.9)$$

Writing $a(x, m) = \sum_{(j,k,l)} a_{j,k,l}(m) \mu^j \epsilon^k x^l$, $b(x, m) = \sum_{(j,k,l)} b_{j,k,l}(m) \mu^j \epsilon^k x^l$, $r(x, m) = \sum_l r_l(m) x^l$, and identifying the coefficients of the term $\mu^j \epsilon^k x^l$ in (2.3.8) and (2.3.9) shows that

$$(2l + 1) b_{j,k,l} + 2(l + 1) b_{j-1,k,l+1} \quad \text{is a finite linear combination of} \\ a_{\tilde{j}, \tilde{k}, \tilde{l}}, \quad (\tilde{j}, \tilde{k}, \tilde{l}) \leq_{LEX} (j, k, l),$$

$$2(l + 1) a_{j,k,l+1} \quad \text{is a finite linear combination of} \\ b_{\tilde{j}, \tilde{k}, \tilde{l}}, \quad (\tilde{j}, \tilde{k}, \tilde{l}) \leq_{LEX} (j, k, l),$$

where \leq_{LEX} is the lexicographic ordering on \mathbb{N}^3 . There is no constraint on the coefficients $a_{(j,k,0)}$, which we choose 0 for $(j, k) \neq (0, 0)$, and $a_{(0,0,0)} = 1$. All the coefficients are now uniquely determined through a transfinite recursion with respect to the \leq_{LEX} -ordering on $(j, k, l) \in \mathbb{N}^3$. \square

2.3.2. Proof of Theorem II.

Lemma 2.3.2. *The analytic invariant γ defined by (2.2.4) of a system*

$$h(z) \frac{d}{dz} - [A^{(0)} + A^{(1)}z] = 0, \quad \text{with} \quad A^{(k)} = \begin{pmatrix} a_{11}^{(k)} & a_{12}^{(k)} \\ a_{21}^{(k)} & a_{22}^{(k)} \end{pmatrix} \quad (2.3.10)$$

and $h(z) = z^2 + h^{(1)}z + h^{(0)}$, is equal to

$$\gamma = 2 \cos 2\pi \sqrt{\left(\frac{a_{11}^{(1)} - a_{22}^{(1)}}{2} \right)^2 + a_{12}^{(1)} a_{21}^{(1)}}. \quad (2.3.11)$$

PROOF. This system considered on the Riemann sphere \mathbb{CP}^1 has singularities only at the zero points of $h(z)$ and at the point $z = \infty$. Therefore in the formula (2.2.4)

$$\gamma = e^{-2\pi i \lambda^{(1)}} \operatorname{tr} M, \quad \text{with} \quad \lambda^{(1)} = \frac{a_{11}^{(1)} + a_{22}^{(1)}}{2},$$

M is a matrix of monodromy around $z = \infty$ in the negative direction. In the coordinate $t = z^{-1}$ the system (2.3.10) is equivalent to

$$t(1 + h^{(1)}t + h^{(0)}t^2) \frac{d}{dt} + [A^{(1)} + A^{(0)}t] = 0, \quad (2.3.12)$$

which has only a regular singularity at $t = 0$. The eigenvalues of its principal matrix $-A^{(1)}$ are $-\lambda^{(1)} \pm \sqrt{D}$ where $D := (\frac{a_{11}^{(1)} - a_{22}^{(1)}}{2})^2 + a_{12}^{(1)} a_{21}^{(1)}$. Suppose first that the singularity is non-resonant, i.e. that $2\sqrt{D} \notin \mathbb{Z}$, in which case there exists a local analytic transformation $T(t)$ near $t = 0$, that brings (2.3.12) to the diagonal system

$$t(1 + h^{(1)}t + h^{(0)}t^2) \frac{d}{dt} + \begin{pmatrix} \lambda^{(1)} + \sqrt{D} & 0 \\ 0 & \lambda^{(1)} - \sqrt{D} \end{pmatrix} = 0,$$

for which an associated diagonal fundamental solution has its monodromy matrix around $t = 0$ in the negative direction equal to

$$M = e^{2\pi i \lambda^{(1)}} \begin{pmatrix} e^{2\pi i \sqrt{D}} & 0 \\ 0 & e^{-2\pi i \sqrt{D}} \end{pmatrix}.$$

Therefore $\gamma = 2 \cos 2\pi \sqrt{D}$.

The resonant case is a limit of non-resonant cases, and the formula (2.3.11) for γ remains valid, because the trace of monodromy depends analytically on the coefficients of A . \square

PROOF OF THEOREM II. Use (2.2.3) to verify that $h(z)$, $\lambda(z)$ and $\alpha(z)$ are indeed the formal invariants of the system $\tilde{\Delta}(h, \lambda, \alpha, q)$ (resp. $\tilde{\Delta}'(h, \lambda, \alpha, b)$).

To verify (2.2.6), set $Q := \frac{1}{2}(-1 \pm \sqrt{1 + 4q})$, so that $q = Q^2 + Q$, and $T(z) := \begin{pmatrix} 1 & 0 \\ Qz & 1 \end{pmatrix}$, then

$$T^* \tilde{\Delta}(h, \lambda, \alpha, q) = h(z) \frac{d}{dz} - \begin{pmatrix} \lambda(z) + Qz & 1 \\ \alpha(z) + (h^{(0)} + h^{(1)}z)Q^2 & \lambda(z) - Qz \end{pmatrix}.$$

Now $\gamma = 2 \cos 2\pi Q = -2 \cos \pi \sqrt{1 + 4q}$ (2.2.6) using (2.3.11).

Also, (2.2.9) follows directly from the formula (2.3.11). If $\gamma(0) \neq -2$, then the equation (2.2.9) with $\beta^{(1)}(m) = \alpha^{(1)}(0) + O(m)$ given by (2.2.8), $\alpha^{(1)}(0) \neq 0$, has an analytic solution $b(m)$ for small m . \square

2.3.3. Systems in the s -coordinate.

Let $\Delta(x, m)$ be a germ of parametric system in the prenormal form of Proposition 2.3.1. The problem of Theorem I(a) is that of proving that two such systems with the same μ, ϵ are analytically equivalent if and only if they have the same trace of monodromy.

Let s be a new coordinate defined by

$$x = s^2 - \mu, \quad (2.3.13)$$

and let

$$S(s) = \begin{pmatrix} 1 & 0 \\ 0 & s \end{pmatrix}, \quad V = \begin{pmatrix} 1 & 1 \\ 1 & -1 \end{pmatrix}. \quad (2.3.14)$$

Then the transformed parametric system $\Delta^s := \frac{1}{s} \cdot (SV)^* \Delta$ in the s -coordinate is equal to

$$\Delta^s(s, m) = \frac{x^2 - \epsilon}{2s^2} \frac{d}{ds} - \left[\begin{pmatrix} 1 & 0 \\ 0 & -1 \end{pmatrix} - \frac{x^2 - \epsilon}{4s^3} \begin{pmatrix} 1 & -1 \\ -1 & 1 \end{pmatrix} + \frac{x^2 - \epsilon}{2s^2} r \begin{pmatrix} 1 & 1 \\ -1 & -1 \end{pmatrix} \right]. \quad (2.3.15)$$

We will be looking for *normalizing transformations* $F_\Omega(s, m)$, defined on some domains Ω in the (s, m) -space, bringing it to a diagonal system $F_\Omega^* \Delta^s = \overline{\Delta}^s$ for

$$\overline{\Delta}^s(s, m) = \frac{x^2 - \epsilon}{2s^2} \frac{d}{ds} - \left[\begin{pmatrix} 1 & 0 \\ 0 & -1 \end{pmatrix} - \frac{x^2 - \epsilon}{4s^3} I \right]. \quad (2.3.16)$$

This diagonal system $\overline{\Delta}^s$ is a *model system* in the s -coordinate. However, the corresponding system $\overline{\Delta} = s \cdot (V^{-1}S^{-1})^* \overline{\Delta}^s$ in the x coordinate,

$$\overline{\Delta}(x, m) = (x^2 - \epsilon) \frac{d}{dx} - \left[\begin{pmatrix} 0 & 1 \\ \mu + x & 0 \end{pmatrix} + \frac{x^2 - \epsilon}{4(\mu + x)} \begin{pmatrix} -1 & 0 \\ 0 & 1 \end{pmatrix} \right],$$

has an additional singularity at the point $x = -\mu$, hence does not belong to the considered class of systems. So instead, in the x -coordinate, we take the *formal normal form* $\widehat{\Delta}(x, m)$ (2.2.12) as the model. Now, if $E_\Omega(s, m)$ is the diagonalizing transformation “ $F_\Omega(s, m)$ ” for the transform $\widehat{\Delta}^s = s^{-1} \cdot (SV)^* \widehat{\Delta}$ of (2.2.12) on a domain Ω , then the composed transformation

$$T_\Omega(x, m) = S(s)VF_\Omega(s, m)E_\Omega(s, m)^{-1}V^{-1}S(s)^{-1}, \quad (2.3.17)$$

defined on the ramified projection of the domain Ω into the x -coordinate, will be non-singular at the point $x = -\mu$ and will bring Δ to $T_\Omega^* \Delta = \widehat{\Delta}$.

The diagonal model system (2.3.16) serves as an intermediate through which to compare systems, and for which one knows an explicit canonical fundamental matrix solution, denoted Ψ (see below). Hence the advantage of the s -coordinate. The lifted system $\Delta^s(s, m)$ then has a canonical fundamental matrix solution $F_\Omega \Psi_\Omega$ on the domain Ω , where Ψ_Ω is a restriction of Ψ on Ω .

Fundamental solution of $\overline{\Delta}^s(s, m)$.

On a neighborhood of ∞ on the Riemann sphere $\mathbb{CP}^1 = \mathbb{C} \cup \{\infty\}$, define the function $\theta(s, \mu, \epsilon)$ by

$$\frac{d}{ds}\theta(s, \mu, \epsilon) = \frac{2s^2}{x^2 - \epsilon} = \frac{2s^2}{(s^2 - \mu)^2 - \epsilon}, \quad \theta(\infty, \mu, \epsilon) = 0. \quad (2.3.18)$$

We have

$$\theta(s, \mu, \epsilon) = \begin{cases} \frac{\sqrt{\mu+\sqrt{\epsilon}}}{2\sqrt{\epsilon}} \log \frac{s-\sqrt{\mu+\sqrt{\epsilon}}}{s+\sqrt{\mu+\sqrt{\epsilon}}} - \frac{\sqrt{\mu-\sqrt{\epsilon}}}{2\sqrt{\epsilon}} \log \frac{s-\sqrt{\mu-\sqrt{\epsilon}}}{s+\sqrt{\mu-\sqrt{\epsilon}}}, & \text{if } \epsilon(\mu^2 - \epsilon) \neq 0, \\ -\frac{s}{s^2 - \mu} - \frac{1}{2\sqrt{\mu}} \log \frac{s+\sqrt{\mu}}{s-\sqrt{\mu}}, & \text{if } \epsilon = 0, \\ -\frac{1}{\sqrt{2\mu}} \log \frac{s-\sqrt{2\mu}}{s+\sqrt{2\mu}}, & \text{if } \mu^2 = \epsilon, \\ -\frac{2}{s}, & \text{if } \mu, \epsilon = 0. \end{cases} \quad (2.3.19)$$

which is analytic in $s \in \mathbb{CP}^1 \setminus \bigcup_{i=1}^4 [0, s_i]$, if each $[0, s_i]$ denotes the closed segment between the origin and a zero point $s_i(\mu, \epsilon)$ of $x^2(s) - \epsilon = (s^2 - \mu)^2 - \epsilon$. The function $\theta(s, \mu, \epsilon)$ is continuous in $(\mu, \epsilon) \in \mathbb{C}^2$ and analytic for $(\mu, \epsilon) \in \mathbb{C}^2 \setminus \{\epsilon(\mu^2 - \epsilon) \neq 0\}$. It is odd in s

$$\theta(-s, \mu, \epsilon) = -\theta(s, \mu, \epsilon),$$

and it satisfies

$$\theta(s, \mu, \epsilon) = \theta(s, e^{2\pi i} \mu, \epsilon) = \theta(s, \mu, e^{2\pi i} \epsilon)$$

for each s in its domain. The function $\theta(s, \mu, \epsilon)$ has a ramified analytic extension $\theta(\check{s}, \check{\mu}, \check{\epsilon})$ defined on a ramified covering of the (s, μ, ϵ) -space with ramification at the zero points $s_i(\check{\mu}, \check{\epsilon})$ of $(s^2 - \mu)^2 - \epsilon$. We will use the notation $(\check{s}, \check{\mu}, \check{\epsilon})$ for the points on this ramified cover that project to (s, μ, ϵ) .

A simple calculation shows that the matrix function

$$\Psi(s, \mu, \epsilon) = \frac{\sqrt{2}}{2} i s^{-\frac{1}{2}} \begin{pmatrix} e^{\theta(s, \mu, \epsilon)} & 0 \\ 0 & e^{-\theta(s, \mu, \epsilon)} \end{pmatrix} \quad (2.3.20)$$

is a *fundamental solution* for the diagonal model system $\overline{\Delta}^s$ (2.3.16).

Fundamental solutions of $\Delta(x, m)$ (resp. $\widehat{\Delta}(x, m)$).

If F_Ω (resp. E_Ω) are normalizing transformations for $\Delta^s(s, m)$ (resp. $\widehat{\Delta}^s(s, m)$) as above, on some domain Ω , and Ψ_Ω is a restriction of Ψ on Ω , then the matrix functions

$$SVF_\Omega \Psi_\Omega, \quad (\text{resp. } SVE_\Omega \Psi_\Omega) \quad (2.3.21)$$

are *fundamental solutions* for the parametric systems $\Delta(x, m)$ (resp. $\widehat{\Delta}(x, m)$).

2.3.4. \mathbb{Z}_2 -symmetry.

Let us remark that if $\Psi_\Omega(s, \mu, \epsilon)$ is a fundamental solution of Δ^s , or $\overline{\Delta}^s$, on a domain $\Omega(m)$ in the s -plane, then $\Psi_\Omega^P(s, m) = \begin{pmatrix} 0 & 1 \\ 1 & 0 \end{pmatrix} \Psi_\Omega(-s, m) \begin{pmatrix} 0 & 1 \\ 1 & 0 \end{pmatrix}$ is a fundamental solution of the same system, this time on a rotated domain $\Omega(m)^P = -\Omega(m)$. Consequently, if F_Ω is a normalizing transformation for Δ^s on a domain Ω , $F_\Omega^* \Delta^s = \overline{\Delta}^s$, then so is F_Ω^P on Ω^P .

The following definition gives the $()^P$ notation precise meaning.

Definition 2.3.3 (Rotation action of \mathbb{Z}_2). If $g(s)$ is a function on some domain Y in the s -space, denote

$$g^P(s) := g(e^{-\pi i} s), \quad s \in Y^P := e^{\pi i} Y$$

the rotated function on the rotated domain. For a 2×2 -matrix function $G(s)$, denote

$$G^P(s) := \begin{pmatrix} 0 & 1 \\ 1 & 0 \end{pmatrix} G(e^{-\pi i} s) \begin{pmatrix} 0 & 1 \\ 1 & 0 \end{pmatrix},$$

and for a constant matrix C ,

$$C^P := \begin{pmatrix} 0 & 1 \\ 1 & 0 \end{pmatrix} C \begin{pmatrix} 0 & 1 \\ 1 & 0 \end{pmatrix}.$$

Equation of the normalizing transformation F_Ω .

We will be looking for F_Ω written as

$$F_\Omega(s, \check{m}) = P_\Omega(s, \check{m}) D_\Omega(s, \check{m}) \tag{2.3.22}$$

with $P_\Omega = \begin{pmatrix} 1 & p_i \\ p_j^P & 1 \end{pmatrix}$ that diagonalizes Δ^s :

$$(P_\Omega)^* \Delta^s = \frac{x^2 - \epsilon}{2s^2} \frac{d}{ds} - \left[\begin{pmatrix} 1 & 0 \\ 0 & -1 \end{pmatrix} - \frac{x^2 - \epsilon}{4s^3} I + \frac{x^2 - \epsilon}{s^2} \begin{pmatrix} \beta_j^P(s) & 0 \\ 0 & -\beta_i(s) \end{pmatrix} \right],$$

and

$$D_\Omega(s, \check{m}) = \begin{pmatrix} e^{\int 2\beta_j^P(s) ds} & 0 \\ 0 & e^{-\int 2\beta_i(s) ds} \end{pmatrix}.$$

This means that the transformation P_Ω needs to satisfy

$$\frac{x^2 - \epsilon}{2s^2} \frac{d}{ds} P_\Omega = \left[\begin{pmatrix} 1 & 0 \\ 0 & -1 \end{pmatrix}, P_\Omega \right] + \frac{x^2 - \epsilon}{4s^3} \begin{pmatrix} 0 & 1 \\ 1 & 0 \end{pmatrix} P_\Omega + r \frac{x^2 - \epsilon}{2s^2} \begin{pmatrix} 1 & 1 \\ -1 & -1 \end{pmatrix} P_\Omega - \frac{x^2 - \epsilon}{s^2} P_\Omega \begin{pmatrix} \beta_j^P & 0 \\ 0 & -\beta_i \end{pmatrix},$$

i.e.

$$\frac{x^2 - \epsilon}{2s^2} \frac{d}{ds} \begin{pmatrix} 0 & p_i \\ p_j^P & 0 \end{pmatrix} = 2 \begin{pmatrix} 0 & p_i \\ -p_j^P & 0 \end{pmatrix} + \frac{x^2 - \epsilon}{4s^3} \begin{pmatrix} p_j^P & 1 \\ 1 & p_i \end{pmatrix} + r \frac{x^2 - \epsilon}{2s^2} \begin{pmatrix} 1+p_j^P & 1+p_i \\ -1-p_j^P & -1-p_i \end{pmatrix} + \frac{x^2 - \epsilon}{s^2} \begin{pmatrix} -\beta_j^P & p_i \beta_i \\ -p_j^P \beta_j^P & \beta_i \end{pmatrix}.$$

The diagonal terms give:

$$\begin{aligned} -\beta_i &= \frac{1}{4s}p_i - \frac{r}{2}(1 + p_i) \\ \beta_j^{\text{P}} &= \frac{1}{4s}p_j^{\text{P}} + \frac{r}{2}(1 + p_j^{\text{P}}). \end{aligned} \quad (2.3.23)$$

The anti-diagonal terms after substitution of (2.3.23) and division by $\frac{x^2-\epsilon}{2s^2}$ are:

$$\begin{aligned} \frac{d}{ds} p_i &= \frac{4s^2}{x^2-\epsilon} p_i + \frac{1}{2s}(1 - p_i^2) + (1 + p_i)^2 r, \\ -\frac{d}{ds} p_j^{\text{P}} &= \frac{4s^2}{x^2-\epsilon} p_j^{\text{P}} - \frac{1}{2s}(1 - (p_j^{\text{P}})^2) + (1 + p_j^{\text{P}})^2 r. \end{aligned}$$

Therefore both p_i, p_j are solutions of the same ODE

$$\frac{d}{ds} p = \frac{4s^2}{x^2-\epsilon} p + \frac{1}{2s}(1 - p^2) + (1 + p)^2 r. \quad (2.3.24)$$

2.3.5. *Solution p_i of (2.3.24) on a ramified domain D_i .*

For each zero $s_i(\check{\mu}, \check{\epsilon})$ of the function $h(x, m) = (s^2 - \mu)^2 - \epsilon$, we construct a ramified domain $D_i(\check{\mu}, \check{\epsilon})$ in the s -space adherent to it, on which there exists a unique bounded solution $p_i(s, \check{m})$ to the equation (2.3.24), obtained as a fixed point of an integral operator associated to the equation. Each domain D_i will be constructed as a ramified union of integration paths of this operator: real trajectories of the vector field $\omega\chi$, with

$$\chi(s, \mu, \epsilon) := \frac{(s^2 - \mu)^2 - \epsilon}{4s^2} \partial_s, \quad (2.3.25)$$

and some $\omega \in \mathbb{C}$. The complex vector field χ is defined on the Riemann sphere $\mathbb{CP}^1 = \mathbb{C} \cup \{\infty\}$, and is polynomial in s^{-1} .

Let the three constants $\delta_s, \delta_\mu, \delta_\epsilon > 0$ determine small discs

$$\mathbb{S} = \{|s| < \delta_s\}, \quad \mathcal{M} = \{|\mu| < \delta_\mu\}, \quad \mathcal{E} = \{|\epsilon| < \delta_\epsilon\}. \quad (2.3.26)$$

And let $s_i(\check{\mu}, \check{\epsilon})$, $i = 1, \dots, 4$, be zeros of $(s^2 - \mu)^2 - \epsilon$ depending continuously on a ramified coordinate $(\check{\mu}, \check{\epsilon})$ from a covering space of $\mathcal{M} \times \mathcal{E}$ (this covering is ramified over the set $\{\epsilon(\mu^2 - \epsilon) = 0\}$ and includes it). The projection map $m \mapsto (\mu(m), \epsilon(m))$ from the parameter space to $\mathcal{M} \times \mathcal{E}$ lifts to a map $\check{m} \mapsto (\check{\mu}(\check{m}), \check{\epsilon}(\check{m}))$ from a covering of the parameter space. We shall suppose that $\delta_\mu, \delta_\epsilon$ are small enough so that all the zero points $s_i(\check{\mu}, \check{\epsilon})$ fall inside \mathbb{S} .

Definition 2.3.4 (Domains D_i). Let a constant $L \geq 2$, determining an annular region in the s -plane

$$|s| < \delta_s, \quad \left| \frac{(s^2 - \mu)^2 - \epsilon}{s^4} \right| < L, \quad (2.3.27)$$

and an angular constant $0 < \eta < \frac{\pi}{2}$ be given. For each value of $(\check{\mu}, \check{\epsilon})$, and a zero point $s_i(\check{\mu}, \check{\epsilon})$ of $(s^2 - \mu)^2 - \epsilon$, we define a *ramified simply connected set* $D_i(\check{\mu}, \check{\epsilon})$ (see Figure 2.2) as the union of real positive trajectories of the vector fields $\omega\chi$,

with continuously varying $-\eta < \arg \omega < \eta$, that end in the point $s_i(\check{\mu}, \check{\epsilon})$ and never leave the annular region (2.3.27). Hence $\check{s} \in D_i(\check{\mu}, \check{\epsilon})$ if there exists $\omega = \omega(\check{s})$, with $\arg \omega \in (-\eta, \eta)$ depending continuously on \check{s} , and a real positive trajectory $\sigma(\xi)$, $\xi \in \mathbb{R}^+$, of the vector field $\omega\chi$, such that

- $\check{s} = \sigma(0)$, $s_i(\check{\mu}, \check{\epsilon}) = \lim_{\xi \rightarrow +\infty} \sigma(\xi)$,
 - $|\sigma(\xi)| < \delta_s$, $|\frac{(\sigma(\xi)^2 - \mu)^2 - \epsilon}{\sigma(\xi)^4}| < L$, for all $\xi \in \mathbb{R}^+$,
 - $\frac{d\sigma}{d\xi} = \omega \frac{(\sigma(\xi)^2 - \mu)^2 - \epsilon}{4\sigma(\xi)^2}$, i.e.
- $$\omega \xi = 2\theta(\sigma(\xi), \mu, \epsilon) - 2\theta(s, \mu, \epsilon), \quad (2.3.28)$$

for the function θ (2.3.19). In particular $s_i(\check{\mu}, \check{\epsilon}) \in D_i(\check{\mu}, \check{\epsilon})$.

For some values of $(\check{\mu}, \check{\epsilon})$ the interior $\mathring{D}_i(\check{\mu}, \check{\epsilon})$ of $D_i(\check{\mu}, \check{\epsilon})$ can be empty. This is the case when $s_i(\check{\mu}, \check{\epsilon})$ is a repulsive point of the real vector field $\omega\chi$ for all admissible ω , or when $s_i(\check{\mu}, \check{\epsilon}) = 0$ and $\mu \neq 0$, in which case s_i is not a singular point of $\omega\chi$.

We set

$$D_i = \bigcup_{\check{m}} D_i(\check{\mu}(\check{m}), \check{\epsilon}(\check{m})) \times \{\check{m}\}.$$

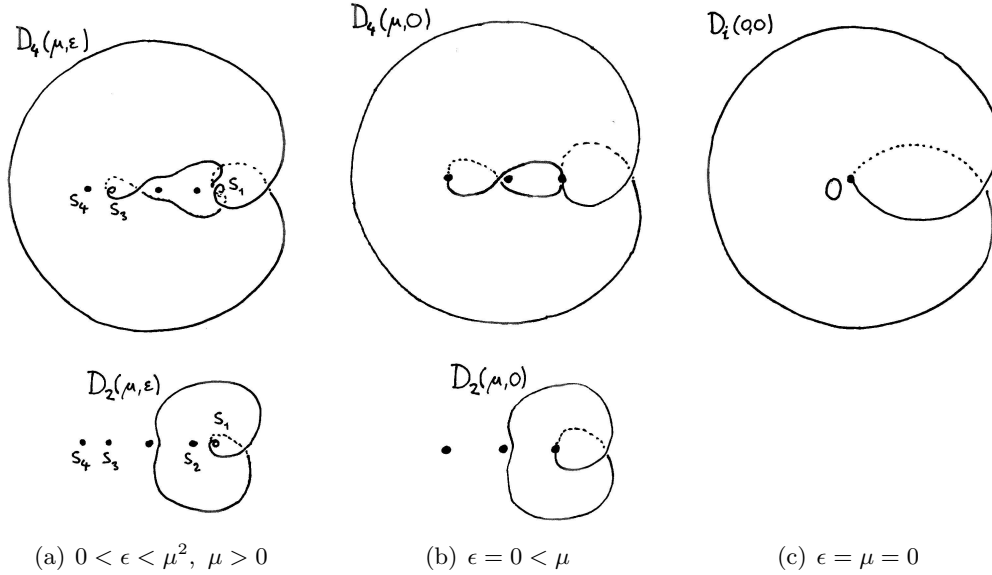

FIGURE 2.2. The domains $D_i(\mu, \epsilon)$ for selected values of μ, ϵ

Lemma 2.3.5. *Let the constants L, η from Definition 2.3.4 satisfy*

$$L\delta_s(1 + 4 \sup_{|s| < \delta_s} |sr|) \leq 2 \cos \eta, \quad (2.3.29)$$

where $r = r(x(s, m), m)$ is as in (2.3.24). Then the equation (2.3.24) possesses a unique solution $p_i \in \mathcal{B}(D_i)$ that is bounded in the domain D_i and satisfies $p_i(s_i(\check{\mu}, \check{\epsilon}), \check{m}) = 0$.

PROOF OF LEMMA 2.3.5. We are looking for a solution $p_i \in \mathcal{B}(D_i)$ of (2.3.24) satisfying $p_i(s_i) = 0$. From the definition of the function θ (2.3.18) and from (2.3.24) we have

$$e^{2\theta} \frac{d}{ds} (e^{-2\theta} p_i) = \frac{dp_i}{ds} - \frac{4s^2}{x^2 - \epsilon} p_i = \frac{1}{2s} (1 - p^2) + (1 + p)^2 r,$$

which we use to rewrite (2.3.24) as an integral equation

$$p_i(s) = \int_{s_i}^s e^{2\theta(s) - 2\theta(\sigma)} \left(\frac{1 - p_i^2(\sigma)}{2\sigma} + (1 + p_i(\sigma))^2 \cdot r(\sigma^2 - \mu) \right) d\sigma := \mathcal{K}_i p_i(s).$$

Taking the real trajectories $\sigma(\xi)$, $\xi \in \mathbb{R}^+$, of the field $\omega\chi$ (2.3.25), $|\omega| = 1$, $|\arg \omega| < \eta$, as the integration trajectories and substituting ξ as in (2.3.28), we obtain

$$\mathcal{K}_i p_i(s) = -\omega \int_0^{+\infty} e^{-\omega\xi} \frac{(\sigma^2 - \mu)^2 - \epsilon}{4\sigma^2} \left(\frac{1 - p_i^2}{2\sigma} + (1 + p_i)^2 \cdot r \right) d\xi$$

We are looking for a fixed point p_i of \mathcal{K}_i in the space of the functions $f \in \mathcal{B}(D_i)$ bounded by 1

$$\|f\| := \sup_{s \in D_i} |f(s)| \leq 1.$$

Using (2.3.27) and (2.3.29) we have

$$\left| \frac{(s^2 - \mu)^2 - \epsilon}{4s^2} \left(\frac{(1 - f(s)^2)}{2s} + (1 + f(s))^2 \cdot r \right) \right| \leq \frac{1}{4} L \delta_s (1 + 4\|sr\|) \leq \frac{1}{2} \cos \eta.$$

Therefore

$$\|\mathcal{K}_i f\| \leq \frac{1}{2} \cos \eta \cdot \int_0^{+\infty} e^{-\operatorname{Re}(\omega)\xi} d\xi \leq \frac{1}{2} \frac{\cos \eta}{\operatorname{Re}(\omega)} \leq \frac{1}{2}.$$

Similarly

$$\begin{aligned} \left| \frac{(s^2 - \mu)^2 - \epsilon}{4s^2} \left(-\frac{f_1 + f_2}{2s} + (2 + f_1 + f_2) \cdot r \right) (f_1 - f_2) \right| &\leq \frac{1}{4} L \delta_s (1 + 4\|sr\|) \|f_1 - f_2\| \\ &\leq \frac{1}{2} \cos \eta \cdot \|f_1 - f_2\|, \end{aligned}$$

and hence

$$\|\mathcal{K}_i f_1 - \mathcal{K}_i f_2\| < \frac{1}{2} \|f_1 - f_2\|.$$

So \mathcal{K}_i is a contraction and the solution p_i of (2.3.24) on D_i exists, and is unique and bounded by 1. \square

2.3.6. Domains Ω and normalizing transformations F_Ω .

If p_i is defined on D_i and p_j^P is defined on D_j^P , then the diagonalizing transformation $F_\Omega(s, \check{m})$ is well defined on a component $\mathring{\Omega}(\check{\mu}, \check{\epsilon})$ of the intersection $D_i(\check{\mu}, \check{\epsilon}) \cap D_j^P(\check{\mu}, \check{\epsilon})$, which is attached to the points $s_i(\check{\mu}, \check{\epsilon})$ and $s_j^P(\check{\mu}, \check{\epsilon}) = -s_j(\check{\mu}, \check{\epsilon})$. We set

$$\Omega(\check{\mu}, \check{\epsilon}) = \mathring{\Omega}(\check{\mu}, \check{\epsilon}) \cup \{s_i(\check{\mu}, \check{\epsilon}), -s_j(\check{\mu}, \check{\epsilon})\},$$

and show that $F_\Omega(\cdot, \check{m})$ extends to $\Omega(\check{\mu}, \check{\epsilon})$.

In order to understand such domains Ω better, we need to understand first the vector field χ (2.3.25).

Remark 2.3.6 (Rotated vector field.). The change of coordinates $(s', \mu', \epsilon') = (\omega s, \omega^2 \mu, \omega^4 \epsilon)$, $\omega \in \mathbb{C}$, transforms the vector field χ to $\omega \chi$:

$$\omega \chi(s, \mu, \epsilon) = \frac{(s'^2 - \mu')^2 - \epsilon'}{s'^2} \partial_{s'}.$$

Bifurcations of the vector field χ .

If in Definition 2.3.4 $\omega = 1$ was fixed, then $D_i(\check{\mu}, \check{\epsilon})$ would be just the attractive basin of the point $s_i(\check{\mu}, \check{\epsilon})$ relative to the annular region (2.3.27). To simplify things further, supposing that $\delta_s = L = +\infty$, i.e. that the annular region is the whole $\mathbb{C} \setminus \infty$, then the interior $\mathring{\Omega}(\check{\mu}, \check{\epsilon})$ of $\Omega(\check{\mu}, \check{\epsilon})$ would be exactly the regions in \mathbb{CP}^1 bounded by the real separatrices of the singularity at the origin of the vector field $\chi(s, \mu, \epsilon)$ and by its unique real trajectory passing through the point at infinity. For a generic value of the parameters $(\check{\mu}, \check{\epsilon})$, this gives 4 different regions: a symmetric pair of inner regions that are bounded solely by the separatrices of the origin, and a symmetric pair of outer regions bounded by the trajectory through ∞ and the separatrices of the origin, see Figure 2.4. When $\epsilon = 0$, each of the inner regions splits in two parts; when $\mu^2 = \epsilon$, the inner regions become empty.

Let us take a better look to how these regions evolve depending on the parameters $(\check{\mu}, \check{\epsilon})$. There are two possibilities for a bifurcation:

Σ_I : when the stability of a zero point s_i of χ changes between attractive and repulsive through a center: the dashed lines in Figure 2.3,

Σ_O : when the trajectory passing by infinity changes its end points: the solid curve in Figure 2.3.

Both of the bifurcations Σ_I, Σ_O are instances of a same phenomenon: appearance of a homoclinic orbit through the origin in \mathbb{CP}^1 .

The bifurcation Σ_I occurs when the multiplier $\frac{\sqrt{\epsilon}}{s_i}$ of the linearization $\frac{\sqrt{\epsilon}}{s_i}(s - s_i)\partial_s$ of vector field χ at the point $s_i = \pm\sqrt{\mu \pm \sqrt{\epsilon}}$ becomes purely imaginary: $\frac{\sqrt{\epsilon}}{\sqrt{\mu \pm \sqrt{\epsilon}}} \in i\mathbb{R}$, which is equivalent to

$$\mu \in \mp\sqrt{\epsilon} - \epsilon\mathbb{R}^+ =: \Sigma_I(\epsilon). \quad (2.3.30)$$

It is well known that a holomorphic vector field in \mathbb{C} is analytically equivalent to its linearization near each simple zero (see e.g. [IY]). As a consequence, if $\mu \in \Sigma_I(\epsilon)$ then the real phase portrait of χ near the point s_i with purely imaginary multiplier is that of a center.

The bifurcation Σ_O occurs when the trajectory through infinity passes by the origin, or equivalently when a separatrix of the origin passes through infinity. This

means that $\theta(0) - \theta(\infty) \in \mathbb{R}$, where θ is as in (2.3.19), i.e. $\pm \frac{\sqrt{\mu+\sqrt{\epsilon}} \pm \sqrt{\mu-\sqrt{\epsilon}}}{2\sqrt{\epsilon}} \pi i \in \mathbb{R}$, which is equivalent to $-\frac{\mu \pm \sqrt{\mu^2 - \epsilon}}{\epsilon} = a \in \mathbb{R}^+$ or

$$\mu \in \left\{ -\frac{1}{2}(a^{-1} + \epsilon a) \mid a > 0 \right\} =: \Sigma_O(\epsilon). \quad (2.3.31)$$

The set $\Sigma_O(\epsilon)$ is a branch of a hyperbola.

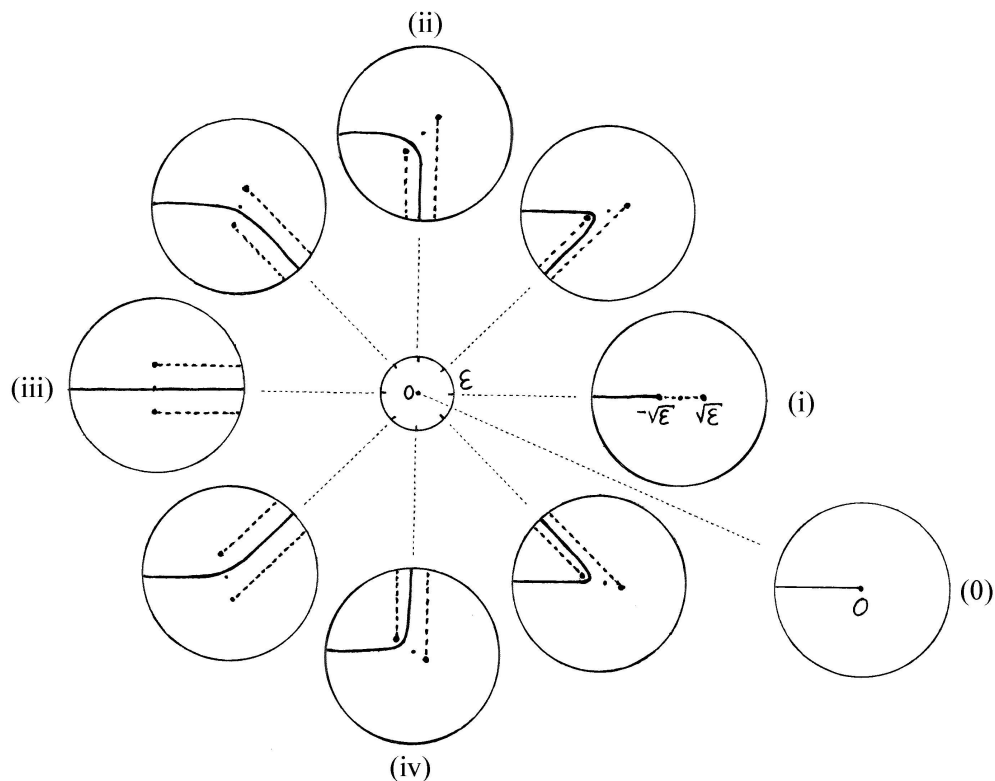
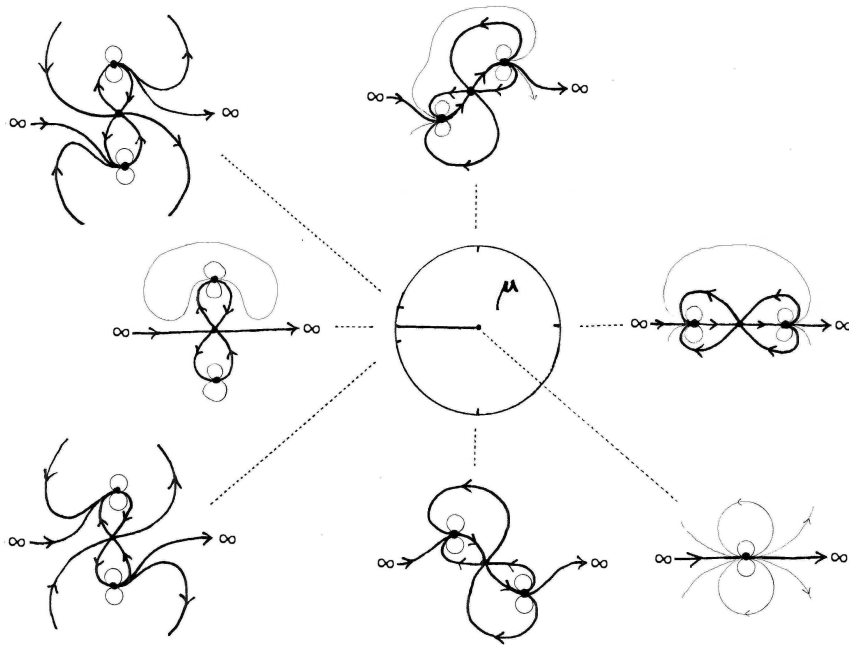
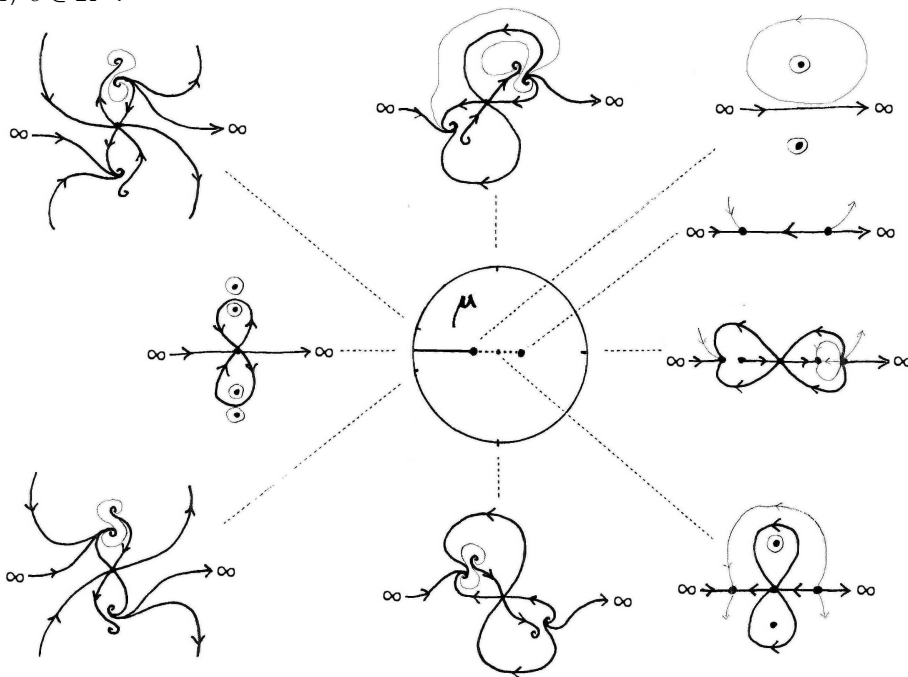

FIGURE 2.3. Bifurcation curves in the μ -plane for the vector field $\chi(s, \mu, \epsilon)$ according to values of ϵ : dashed lines $\Sigma_I(\epsilon)$ correspond to change of stability of a singular point, solid line curve $\Sigma_O(\epsilon)$ corresponds to bifurcation of the trajectory passing through ∞ .

(0) $\epsilon = 0$:



(i) $\epsilon \in \mathbb{R}^+$:



(ii) $\epsilon \in -i\mathbb{R}^+$:

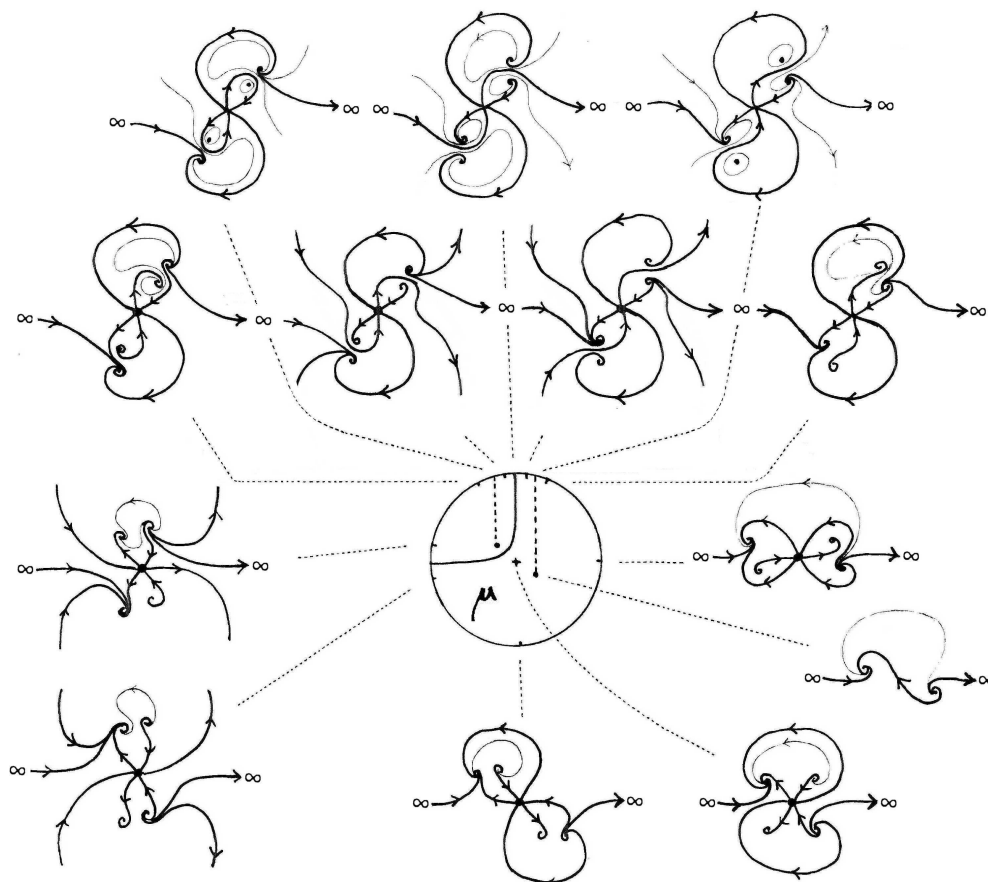

(iii) $\epsilon \in -\mathbb{R}^+$:

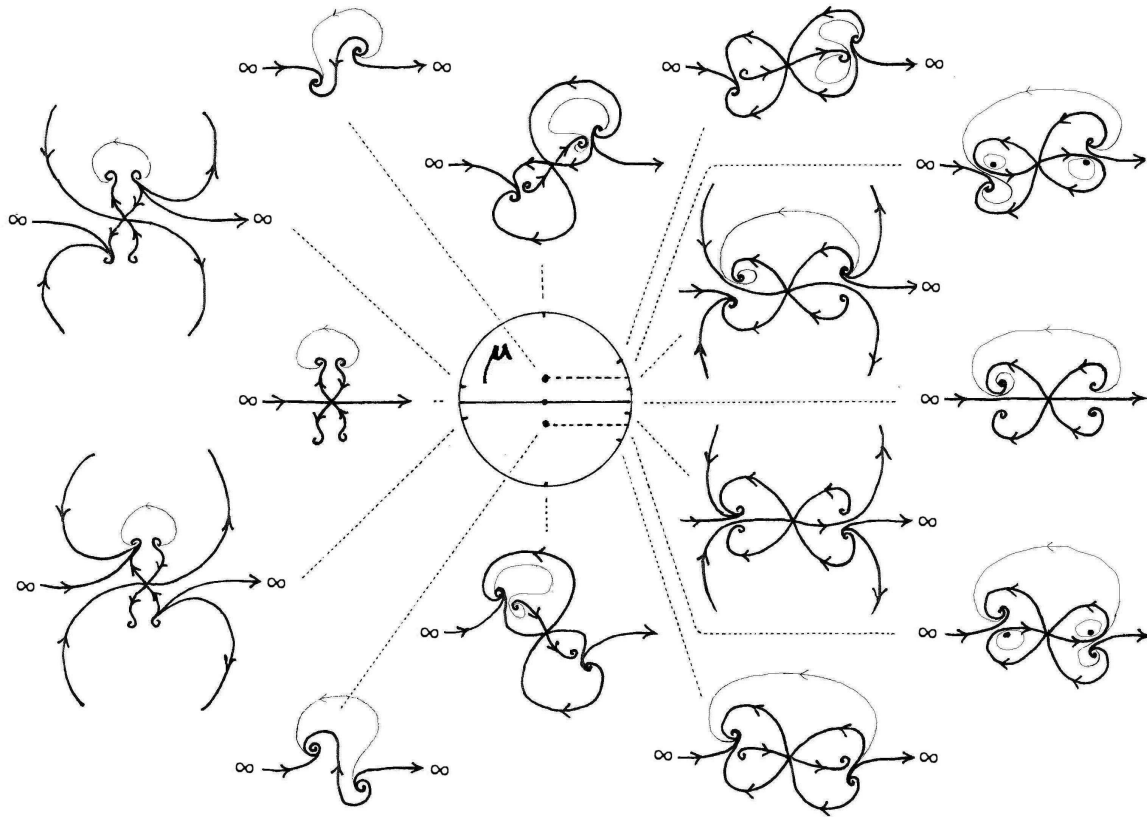

(iv) $\epsilon \in i\mathbb{R}^+$:

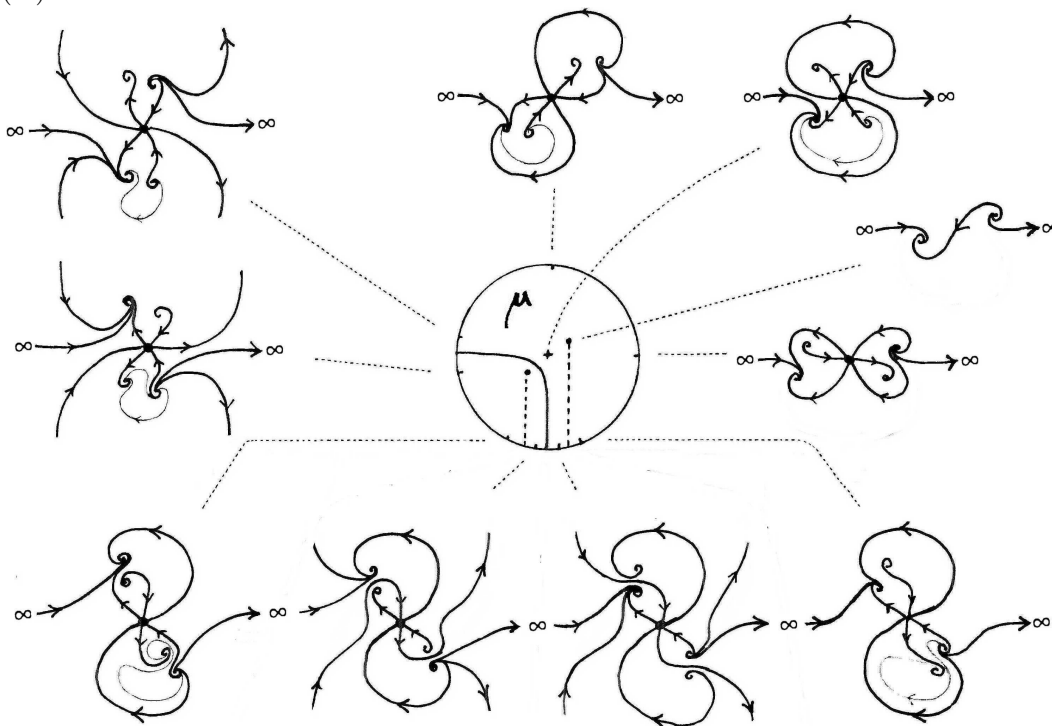

FIGURE 2.4. The real phase portrait of the vector field χ according to μ for selected values of ϵ .

The ramified domains Ω .

From the construction, a point \check{s} belongs to $\mathring{\Omega}(\check{\mu}, \check{\epsilon})$ if there exists ω_+ (resp. ω_-) for which the positive trajectory of $\omega_+\chi$ (resp. negative trajectory of $\omega_-\chi$) starting at \check{s} stays within the annular region (2.3.27) and connects to the point $s_i(\check{\mu}, \check{\epsilon})$ (resp. $-s_j(\check{\mu}, \check{\epsilon})$). We will not lose much by restricting $\mathring{\Omega}(\check{\mu}, \check{\epsilon})$ only to the points for which the same $\omega_+ = \omega_- =: \omega$ is admissible, in another words, the whole real trajectory of $\omega\chi$ through \check{s} stays inside the annular region. Let us take a closer look at such domains Ω .

For each ω , $|\omega| = 1$, and a generic value of (μ, ϵ) the vector field $\omega\chi(s, \mu, \epsilon)$ has 4 connected zones consisting of complete real trajectories inside the annulus (2.3.27): a symmetric pair of inner regions, denote them $R_{I,\omega}(\check{\mu}, \check{\epsilon})$, $R_{I,\omega}^P(\check{\mu}, \check{\epsilon})$, and a symmetric pair of outer regions, denote them $R_{O,\omega}(\check{\mu}, \check{\epsilon})$, $R_{O,\omega}^P(\check{\mu}, \check{\epsilon})$, see Figure 2.5 (a).

Depending on (μ, ϵ) the following can happen: When $\omega^2\mu \in \Sigma_I(\omega^4\epsilon) \cup \{\pm\omega^2\sqrt{\epsilon}\}$, the inner regions $R_{I,\omega}(\check{\mu}, \check{\epsilon})$ become empty, and they split in two components when $\epsilon = 0$, $\mu \neq 0$. The outer regions $R_{O,\omega}(\check{\mu}, \check{\epsilon})$ are empty whenever a separatrix of the origin of the field $\omega\chi(s, \mu, \epsilon)$ leaves the disc of radius δ_s (2.3.27): this happens for values of (μ, ϵ) close to the bifurcation set Σ_O (2.3.31), see Figure 2.5 (b). Therefore a bifurcation of the region $R_{O,\omega}$ occurs when a separatrix of the origin touches the boundary of the disc of radius δ_s from inside for the first time: at that moment the region ceases to exist as no outer points can be joined to both s_i and $-s_j$ inside the annulus.

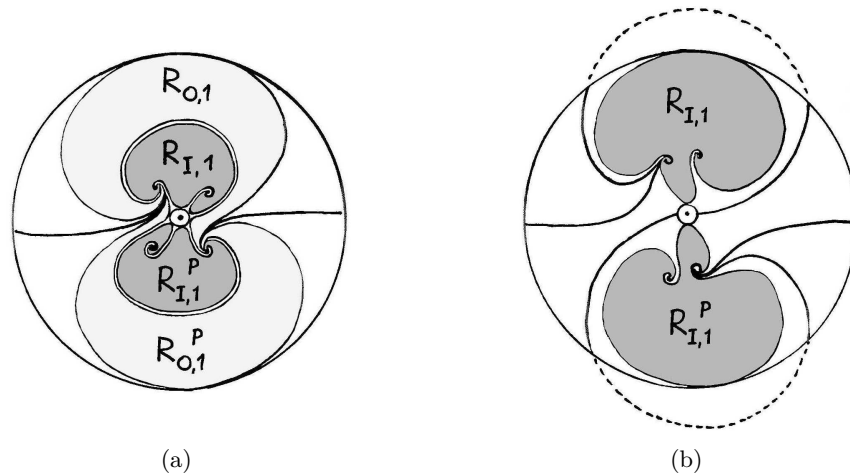

FIGURE 2.5. The outer and inner regions $R_{O,1}(\check{\mu}, \check{\epsilon})$ and $R_{I,1}(\check{\mu}, \check{\epsilon})$ (with $\omega = 1$) inside the annulus (2.3.27) for (a) $\epsilon \in i\mathbb{R}^+$, $\mu = 0$, (b) $\epsilon \in i\mathbb{R}^+$, μ close to $\Sigma_I(\epsilon)$: $R_{O,1} = R_{O,1}^P = \emptyset$. Compare with the corresponding vector fields in Figure 2.4 (ii).

Corresponding to the inner and outer regions of the vector field χ there are four domains Ω : a symmetric pair of inner domains Ω_I, Ω_I^P , and a symmetric pair of outer domains Ω_O, Ω_O^P , obtained as ramified unions of the regions $R_{I,\omega}, R_{I,\omega}^P$ and $R_{O,\omega}, R_{O,\omega}^P$ over varying ω . They experience the same kind of bifurcations as their corresponding regions $R_{\bullet,\omega}$, but this time it is delayed by the effect of the variation of $\arg \omega \in (-\eta, \eta)$. This will determine the set of ramified parameters $(\check{\mu}, \check{\epsilon})$ for which they exist.

Let \mathcal{M}, \mathcal{E} (2.3.26) be small discs of radii $\delta_\mu, \delta_\epsilon$ in the μ - and ϵ -spaces, and let η be as in Definition 2.3.4. Define a ramified sectorial cover $\check{\mathcal{E}}$ of \mathcal{E} as

$$\check{\mathcal{E}} = \{\check{\epsilon} \mid |\check{\epsilon}| < \delta_\epsilon \ \& \ |\arg \check{\epsilon}| < 2\pi + \eta\},$$

with each $\check{\epsilon}$ being projected to $\epsilon \in \mathcal{E}$. For each value of ω and $\check{\epsilon} \in \check{\mathcal{E}}$, let $\mathcal{M}_\omega(\check{\epsilon})$ denote the connected component of the set $\{\mu \in \mathcal{M} \mid R_{O,\omega}(\check{\mu}, \check{\epsilon}) \neq \emptyset\} \setminus \Sigma_1(\epsilon)$ that contains the point $\mu = \sqrt{\check{\epsilon}}$. By Remark 2.3.6

$$R_{\bullet,\omega}(\check{\mu}, \check{\epsilon}) = \omega^{-1} R_{\bullet,1}(\omega^2 \check{\mu}, \omega^4 \check{\epsilon}), \quad \bullet = O, I,$$

hence $\mathcal{M}_\omega(\check{\epsilon}) = \omega^{-2} \mathcal{M}_1(\omega^4 \check{\epsilon})$. Define the domain $\check{\mathcal{M}}(\check{\epsilon})$ of ramified parameter $\check{\mu}$ as a ramified union

$$\check{\mathcal{M}}(\check{\epsilon}) = \bigcup_{\substack{|\omega|=1 \\ |\arg \omega| < \eta}} \mathcal{M}_\omega(\check{\epsilon}) = \bigcup_{\substack{|\omega|=1 \\ |\arg \omega| < \eta}} \omega^{-2} \mathcal{M}_1(\omega^4 \check{\epsilon}),$$

with $\check{\mu} = \sqrt{\check{\epsilon}}$ as the ramification point included in $\check{\mathcal{M}}(\check{\epsilon})$. See Figure 2.6.

To fix the notation, from now on, let

$$s_1(\check{\mu}, \check{\epsilon}) := \sqrt{\check{\mu} + \sqrt{\check{\epsilon}}}, \quad s_2(\check{\mu}, \check{\epsilon}) := \sqrt{\check{\mu} - \sqrt{\check{\epsilon}}} \quad (2.3.32)$$

such that for $\arg \epsilon = 0$ and $\mu > \sqrt{\epsilon} > 0$ they are given by the usual square root. Let's agree that out of the two inner regions, $R_{I,\omega}(\check{\mu}, \check{\epsilon})$ is the one consisting of trajectories from $s_1(\check{\mu}, \check{\epsilon})$ to $s_2(\check{\mu}, \check{\epsilon})$, and that out of the two outer regions (both consisting of trajectories from $s_1(\check{\mu}, \check{\epsilon})$ to $-s_1(\check{\mu}, \check{\epsilon})$), $R_{O,\omega}(\check{\mu}, \check{\epsilon})$ is the upper one (Figure 2.5).

For each $\check{m} \in \check{\mathcal{M}}$ let

$$\mathring{\Omega}_{\bullet}(\check{\mu}, \check{\epsilon}) = \bigcup_{\substack{\omega \text{ such that} \\ \mu \in \mathcal{M}_\omega(\check{\epsilon})}} R_{\bullet,\omega}(\check{\mu}, \check{\epsilon}), \quad \bullet = O, I \quad (2.3.33)$$

be a ramified union of the regions in the s -plane, and let

$$\Omega_I(\check{\mu}, \check{\epsilon}) \quad (\text{resp. } \Omega_O(\check{\mu}, \check{\epsilon}))$$

be $\mathring{\Omega}_I(\check{\mu}, \check{\epsilon})$ (resp. $\mathring{\Omega}_O(\check{\mu}, \check{\epsilon})$) with the corresponding zero points $s_1(\check{\mu}, \check{\epsilon}), s_2(\check{\mu}, \check{\epsilon})$ (resp. $s_1(\check{\mu}, \check{\epsilon}), -s_1(\check{\mu}, \check{\epsilon})$) of $(s^2 - \mu)^2 - \epsilon$ from its adherence added as in Proposition 2.3.7.

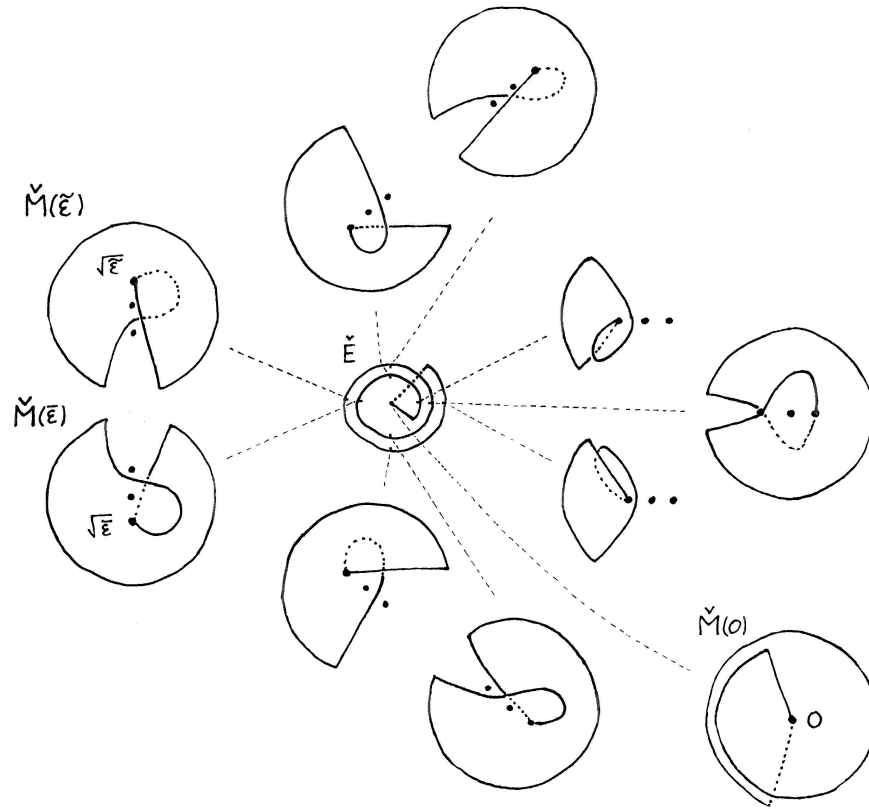

FIGURE 2.6. The ramified domains $\check{M}(\check{\epsilon})$ for the parameter $\check{\mu}$ depending on $\check{\epsilon} \in \check{\mathcal{E}}$.

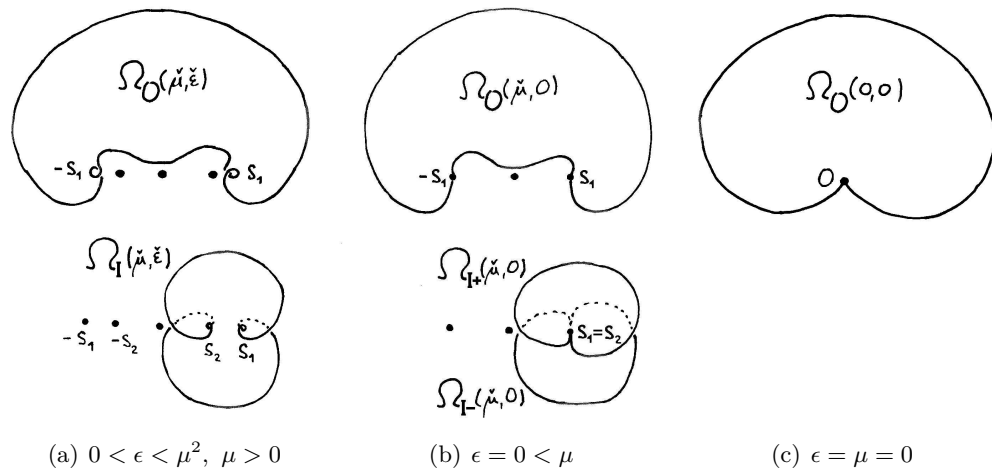

FIGURE 2.7. The domains $\Omega_O(\check{\mu}, \check{\epsilon})$ and $\Omega_I(\check{\mu}, \check{\epsilon})$ for selected values of μ, ϵ .

While the outer domain $\Omega_O(\check{\mu}, \check{\epsilon})$ is connected nonempty for all $\check{\epsilon} \in \check{\mathcal{M}}, \check{\mu} \in \check{M}(\check{\epsilon})$, following from its construction, the inner domain becomes empty whenever $\mu^2 = \epsilon$, and splits into two components if $\epsilon = 0$: $\Omega_I(\check{\mu}, 0) = \Omega_{I^+}(\check{\mu}, 0) \cup \Omega_{I^-}(\check{\mu}, 0)$, with a common point $s_1(\check{\mu}, 0) = s_2(\check{\mu}, 0) = \sqrt{\check{\mu}}$ (see Figure 2.7).

If $\bar{\epsilon} \in \check{\mathcal{E}} \cap e^{-2\pi i} \check{\mathcal{E}}$ and $\tilde{\epsilon} = e^{2\pi i} \bar{\epsilon} \in \check{\mathcal{E}} \cap e^{2\pi i} \check{\mathcal{E}}$ are two ramified parameters in $\check{\mathcal{E}}$ that correspond to the same ϵ , then the two domains $\check{\mathcal{M}}(\bar{\epsilon})$, $\check{\mathcal{M}}(\tilde{\epsilon})$ form together a ramified cover of the μ -space \mathcal{M} (if δ_μ , δ_ϵ in (2.3.26) are sufficiently small), see Figure 2.6.

The union of $\check{\mathcal{M}}(\check{\epsilon})$ in the $(\check{\mu}, \check{\epsilon})$ -space

$$\bigcup_{\check{\epsilon} \in \check{\mathcal{E}}} \check{\mathcal{M}}(\check{\epsilon}) \times \{\check{\epsilon}\}$$

is a single simply connected ramified cover of $\mathcal{M} \times \mathcal{E}$.

We define the ramified domain $\check{\mathcal{M}}$ in the \check{m} -space, covering a neighborhood \mathbf{M} of 0 in the m -space, by lifting this ramified cover $(\mu(m), \epsilon(m)) : \mathbf{M} \rightarrow \mathcal{M} \times \mathcal{E}$

$$\begin{array}{ccc} \check{\mathcal{M}} \ni \check{m} & \longmapsto & (\check{\mu}(\check{m}), \check{\epsilon}(\check{m})) \in \bigcup_{\check{\epsilon} \in \check{\mathcal{E}}} \check{\mathcal{M}}(\check{\epsilon}) \times \{\check{\epsilon}\} \\ \downarrow & & \downarrow \\ \mathbf{M} \ni m & \longmapsto & (\mu(m), \epsilon(m)) \in \mathcal{M} \times \mathcal{E} \end{array}$$

Finally let Ω_\bullet be the union of all $\Omega_\bullet(\check{\mu}, \check{\epsilon})$ \check{m} -fibered over $\check{\mathcal{M}}$

$$\Omega_\bullet := \bigcup_{\check{m} \in \check{\mathcal{M}}} \Omega_\bullet(\check{\mu}(\check{m}), \check{\epsilon}(\check{m})) \times \{\check{m}\}.$$

Proposition 2.3.7. *Let a parametric system $\Delta^s(s, m)$ be as in (2.3.15) and its diagonal model $\bar{\Delta}^s(s, m)$ be as in (2.3.16). On the domains Ω_\bullet and $\Omega_\bullet^P = e^{\pi i} \Omega_\bullet$, $\bullet = O, I$, defined above, there exists unique diagonalizing transformations*

$$\begin{aligned} F_\bullet &\in \mathrm{GL}_2(\mathcal{B}(\Omega_\bullet)), & (F_\bullet)^* \Delta^s &= \bar{\Delta}^s \\ F_\bullet^P &\in \mathrm{GL}_2(\mathcal{B}(\Omega_\bullet^P)), & (F_\bullet^P)^* \Delta^s &= \bar{\Delta}^s \end{aligned}$$

(see Definition 2.2.11 and Notation 2.3.3), such that

$$\begin{aligned} F_I(s_1, \check{\mu}, \check{\epsilon}) &= \begin{pmatrix} 1 & 0 \\ 0 & \kappa_I(\check{\mu}, \check{\epsilon}) \end{pmatrix}, & F_I(s_2, \check{\mu}, \check{\epsilon}) &= \begin{pmatrix} \kappa_I(\check{\mu}, \check{\epsilon}) & 0 \\ 0 & 1 \end{pmatrix}, \\ F_O(s_1, \check{\mu}, \check{\epsilon}) &= \begin{pmatrix} 1 & 0 \\ 0 & \kappa_O(\check{\mu}, \check{\epsilon}) \end{pmatrix}, & F_O(s_2, \check{\mu}, \check{\epsilon}) &= \begin{pmatrix} \kappa_O(\check{\mu}, \check{\epsilon}) & 0 \\ 0 & 1 \end{pmatrix}, \end{aligned} \tag{2.3.34}$$

where the functions $\kappa_O, \kappa_I \in \mathcal{C}(\check{\mathcal{M}}) \cap \mathcal{O}(\mathrm{int} \check{\mathcal{M}})$ are uniquely determined by Δ^s .

PROOF. By construction,

$$F_\Omega(s, \check{m}) = \begin{pmatrix} 1 & p_i \\ p_j^P & 1 \end{pmatrix} \begin{pmatrix} e^{\int_{s_j^P}^s 2\beta_j^P(\sigma) d\sigma} & 0 \\ 0 & e^{-\int_{s_i}^s 2\beta_i(\sigma) d\sigma} \end{pmatrix}$$

with $\beta_k = -\frac{1}{4s}p_k + \frac{r}{2}(1 + p_k)$, so it is well defined and bounded on the component $\mathring{\Omega}$ of the intersection $D_i \cap D_j^P$. We need to show that the limits

$$F_\Omega(s_k, \check{m}) = \lim_{s \rightarrow s_k} F_\Omega(s, \check{m}), \quad s_k = s_i, -s_j$$

exist and are diagonal. In fact, for each \check{m} fixed and $s_k(\check{\mu}, \check{\epsilon})$ a singular point of Δ_m^s , it is well known from the non-parametric theory that there exists a diagonalizing transformation defined on the restriction of $\Omega(\check{\mu}, \check{\epsilon})$ to a small neighborhood of the point, which extends continuously as I to $s_k(\check{\mu}, \check{\epsilon})$ (cf. Remark 2.2.10). Therefore $F_\Omega(\cdot, \check{m})$ is related to such a transformation by right side multiplication by a bounded automorphism of $\overline{\Delta}_m^s$. Lemma 2.3.8 below shows that this automorphism extends continuously to the point s_k as a diagonal matrix, therefore $F_\Omega(s_k(\check{\mu}, \check{\epsilon}), \check{\mu}, \check{\epsilon})$ exist and is diagonal. The unicity of F_Ω follows from Corollary 2.3.9 below.

Using the Liouville–Ostrogradski formula we know that the determinant of the fundamental solution $\Phi_\Omega = SVF_\Omega\Psi_\Omega$ (2.3.21) of $\Delta(x, m)$ is constant for each $(\check{\mu}, \check{\epsilon})$ fixed since the trace of the matrix of this system is null; therefore

$$\det F_\Omega(s, m) = \det \Phi_\Omega(x, m) = \kappa_\Omega(m) \in \mathbb{C}^*.$$

If $F_\Omega(s_i)$ is diagonal, then we also know from the construction that $F_\Omega(s_i)$ has 1 at the second diagonal position, and similarly that $F_\Omega(-s_j)$ has 1 at the first diagonal position, so we obtain (2.3.34). \square

Automorphisms of $\overline{\Delta}^s$

Lemma 2.3.8. *For m fixed, let U be a simply connected open subset of $\mathbb{C} \setminus \{s \mid (s^2 - \mu(m)) - \epsilon(m) = 0\}$ and let $A_U(s)$ be an automorphism of the diagonal system $\overline{\Delta}_m^s$ (2.3.16): $(A_U)^* \overline{\Delta}_m^s = \overline{\Delta}_m^s$. If $\Psi(s)$ is a fundamental solution (2.3.20) of $\overline{\Delta}_m^s$, we have*

$$A_U(s) = \Psi(s)C\Psi(s)^{-1}$$

for some constant invertible matrix $C = (c_{kl})$. If A_U is bounded on U , and if U contains a real-positive trajectory $\sigma_+(\xi)$ of $\omega_+\chi$ (resp. a real-negative trajectory $\sigma_-(\xi)$ of $\omega_-\chi$) for some ω_\pm , $|\arg \omega_\pm| < \frac{\pi}{2}$, then necessarily $c_{12} = 0$ (resp. $c_{21} = 0$) and

$$\lim_{\xi \rightarrow +\infty} A_U(\sigma_+(\xi)) = \begin{pmatrix} c_{11} & 0 \\ 0 & c_{22} \end{pmatrix} \quad \left(\text{resp.} \quad = \lim_{\xi \rightarrow -\infty} A_U(\sigma_-(\xi)) \right).$$

PROOF. Let $\theta(s)$ be a branch of the function $\theta(s, \mu, \epsilon)$ in (2.3.19) on U . We have

$$A_U(s) = \begin{pmatrix} c_{11} & e^{2\theta(s)}c_{12} \\ e^{-2\theta(s)}c_{21} & c_{22} \end{pmatrix}.$$

If $|\arg \omega_{\pm}| < \frac{\pi}{2}$, then it follows from (2.3.28) that $\operatorname{Re}(\theta(\sigma_+(\xi))) \rightarrow +\infty$ as $\xi \rightarrow +\infty$ (resp. $\operatorname{Re}(\theta(\sigma_-(\xi))) \rightarrow -\infty$ as $\xi \rightarrow -\infty$), which implies that $c_{12} = 0$ (resp. $c_{21} = 0$), else $A_U(\sigma_{\pm})$ would not be bounded. \square

Corollary 2.3.9. *An automorphism A_{Ω} of $\overline{\Delta}^s$ (2.3.16) on a domain Ω of Proposition 2.3.7 is just a diagonal matrix constant w.r.t. s .*

Proof of Theorem III

PROOF OF THEOREM III. Let $\check{x}(\check{s}, m) = \check{s}^2 - \check{\mu}(m)$, a one-to-one map from the ramified coordinate \check{s} to a ramified coordinate \check{x} (projecting on x), be a lifting of the map $x(s, m) = s^2 - \mu(m)$ (2.3.13). Then the ramified images of Ω_O, Ω_I in the \check{x} -coordinate: $\check{x}(\Omega_O(\check{\mu}, \check{\epsilon})) \cap \check{X}, \check{x}(\Omega_I(\check{\mu}, \check{\epsilon})) \cap \check{X}$, cover for each $(\check{\mu}, \check{\epsilon})$ a full neighborhood of each singular point $x = \pm\sqrt{\epsilon}$. Define

$$O(\check{\mu}, \check{\epsilon}), \quad I(\check{\mu}, \check{\epsilon}),$$

depending continuously on $\check{m} \in \mathbb{M}$, as simply connected ramified extensions of these images, in such a way that they agree with them near each singularity, are open away of the singularities, and the union of their projections covers all \mathbb{X} for each \check{m} . In particular, we want to cover the points $x = \mu$ corresponding to $s = 0$, which was not covered by $\Omega_O \cup \Omega_I$. Since the fundamental solutions $SVF_{\bullet}\Psi_{\bullet}$ of $\Delta(x, m)$ and $SVE_{\bullet}\Psi_{\bullet}$ of $\widehat{\Delta}(x, m)$ (see Section 2.3.3) are analytic away from the singularities $x = \pm\sqrt{\epsilon}$, the transformations (2.3.17)

$$T_{\bullet}(\check{x}, \check{m}) = S(s)VF_{\bullet}(\check{s}, \check{m})E_{\bullet}(\check{s}, \check{m})^{-1}V^{-1}S(s)^{-1}, \quad \bullet = O, I$$

extend then on $\bullet = O, I$ as normalizing transformation for the parametric system $\Delta(x, m)$:

$$T_{\bullet} \in \operatorname{GL}_2(\mathcal{B}(\bullet)), \quad T_{\bullet}^* \Delta = \widehat{\Delta}.$$

\square

2.3.7. Connection matrices and proof of Theorem I (a).

For the following discussion we will want to fix a branch Ψ_{\bullet} of the fundamental solution Ψ (2.3.20) of the diagonal system $\overline{\Delta}^s$ on each of the domains Ω_{\bullet} . In order to do so, we need to split the inner domain $\Omega_I(\check{\mu}, \check{\epsilon})$ in two parts: $\Omega_{I+}(\check{\mu}, \check{\epsilon})$ and $\Omega_{I-}(\check{\mu}, \check{\epsilon})$, corresponding to the two components of $\mathring{\Omega}_I(\check{\mu}, 0)$ when $\check{\epsilon} = 0$.

First we divide each inner region $R_{I,\omega}(\check{\mu}, \check{\epsilon})$ of the field ω_{χ} into two parts by cutting it along a chosen trajectory going from the repelling point $s_1(\check{\mu}, \check{\epsilon})$ to the attracting point $s_2(\check{\mu}, \check{\epsilon})$: If θ is the function (2.3.19), one knows that the imaginary

part of $\omega^{-1}\theta$ stays constant along each trajectory. Using (2.3.32), we can write θ as

$$\theta(\check{s}, \check{\mu}, \check{\epsilon}) = \frac{s_1(\check{\mu}, \check{\epsilon})}{2\sqrt{\check{\epsilon}}} \log \frac{s-s_1(\check{\mu}, \check{\epsilon})}{s+s_1(\check{\mu}, \check{\epsilon})} - \frac{s_2(\check{\mu}, \check{\epsilon})}{2\sqrt{\check{\epsilon}}} \log \frac{s-s_2(\check{\mu}, \check{\epsilon})}{s+s_2(\check{\mu}, \check{\epsilon})},$$

and we know (by setting $s = \infty$) that points on the unique trajectory from s_1 through ∞ satisfy

$$\operatorname{Im} \left(\frac{\theta(\check{s}, \check{\mu}, \check{\epsilon})}{\omega} \right) = 0.$$

To cut $R_{I,\omega}$ we will use the “opposite” outgoing trajectory from s_1 , that is the trajectory, whose points s satisfy

$$\operatorname{Im} \left(\frac{\theta(\check{s}, \check{\mu}, \check{\epsilon})}{\omega} \right) = \pm \operatorname{Im} \left(\frac{s_1(\check{\mu}, \check{\epsilon})}{\omega 2\sqrt{\check{\epsilon}}} \pi i \right)$$

(the sign depends on from which side does one extend the function θ , the both correspond to the same trajectory in the s -plane).

For each ω this trajectory divides $R_{I,\omega}$ into: $R_{I+,\omega}$ and $R_{I-,\omega}$, see Figure 2.8 (a).

We define $\Omega_{I+}(\check{\mu}, \check{\epsilon})$ and $\Omega_{I-}(\check{\mu}, \check{\epsilon})$ in the same way as in (2.3.33) for each $\check{\mu}^2 \neq \check{\epsilon}$. Hence

$$\Omega_I = \Omega_{I+} \cup \Omega_{I-}, \quad (\text{see Figure 2.8 (b)})$$

and we set $F_{I+} = F_I|_{I+}$ and $F_{I-} = F_I|_{I-}$.

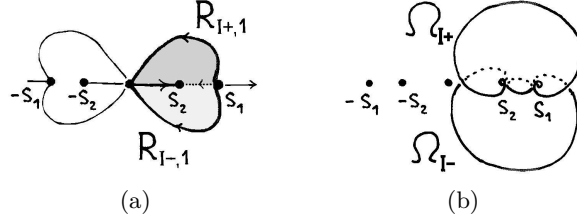

FIGURE 2.8. (a) The regions $R_{I\pm,1}(\check{\mu}, \check{\epsilon})$ of the vector field χ with the dividing trajectory from s_1 to s_2 dotted. (Picture with $\epsilon, \mu \in \mathbb{R}^+$, $\mu^2 > \epsilon$, compare to Figure 2.4 (i).) (b) The corresponding domains $\Omega_{I+}(\check{\mu}, \check{\epsilon})$ and $\Omega_{I-}(\check{\mu}, \check{\epsilon})$, where $\Omega_I(\check{\mu}, \check{\epsilon}) = \Omega_{I+}(\check{\mu}, \check{\epsilon}) \cup \Omega_{I-}(\check{\mu}, \check{\epsilon})$ is as in Figure 2.7 (a).

Definition 2.3.10. Let Φ_1, Φ_2 be two fundamental matrix solutions of a linear system on two domains U_1, U_2 with connected non-empty intersection $U_1 \cap U_2$. We call the matrix $C = \Phi_1^{-1}\Phi_2$ a *connection matrix* between Φ_1 and Φ_2 and represent it schematically as

$$\Phi_1 \xrightarrow{C} \Phi_2.$$

Choice of fundamental solutions Ψ_\bullet .

On the interior $\mathring{\Omega}_\bullet$ of each of the domains Ω_\bullet , $\bullet = O, I+, I-$, we fix a branch $\Psi_\bullet(\check{s}, \check{\mu}, \check{\epsilon})$ of the fundamental solution $\Psi(\check{s}, \check{\mu}, \check{\epsilon})$ (2.3.20) of the diagonal system $\overline{\Delta}^s$ so that the connection matrices between them are as in Figure 2.9.

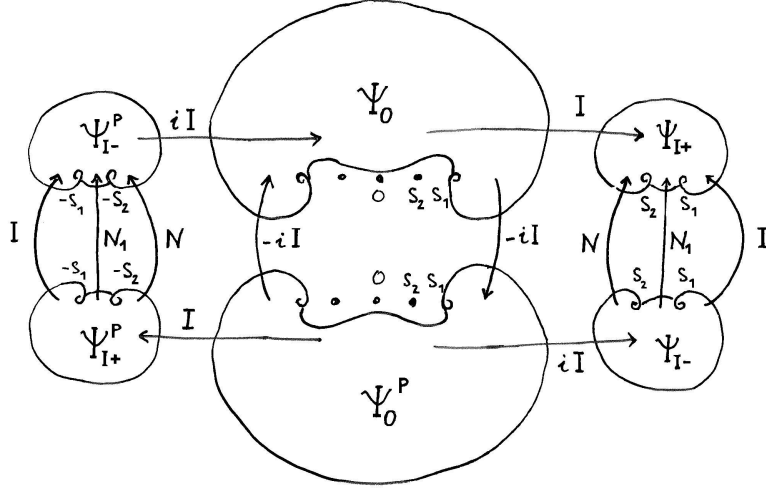

FIGURE 2.9. The connection matrices between the fundamental solutions Ψ_\bullet for each fixed parameter $(\check{\mu}, \check{\epsilon})$, with $\check{\mu}^2 \neq \check{\epsilon} \neq 0$, where N_1 and N are given by (2.3.35) and (2.3.36). If $\check{\epsilon} = 0$ then $s_1(\check{\mu}, 0) = s_2(\check{\mu}, 0)$ and the matrices N_1 are missing from the picture. If $\check{\mu}^2 = \check{\epsilon}$ then only the fundamental solutions Ψ_O and Ψ_O^P persist together with the two connection matrices $-iI$.

The monodromy matrices of $\Psi(s, \check{\mu}, \check{\epsilon})$ around the points $s_1(\check{\mu}, \check{\epsilon})$, resp. $s_2(\check{\mu}, \check{\epsilon})$, in the positive direction are independent of the choice of the branch, and are given by

$$N_1(\check{\mu}, \check{\epsilon}) = \begin{pmatrix} e^{\frac{s_1(\check{\mu}, \check{\epsilon})\pi i}{\sqrt{\check{\epsilon}}}} & 0 \\ 0 & e^{-\frac{s_1(\check{\mu}, \check{\epsilon})\pi i}{\sqrt{\check{\epsilon}}}} \end{pmatrix}, \quad N_2(\check{\mu}, \check{\epsilon}) = \begin{pmatrix} e^{-\frac{s_2(\check{\mu}, \check{\epsilon})\pi i}{\sqrt{\check{\epsilon}}}} & 0 \\ 0 & e^{\frac{s_2(\check{\mu}, \check{\epsilon})\pi i}{\sqrt{\check{\epsilon}}}} \end{pmatrix}, \quad (2.3.35)$$

They satisfy

$$N_i^P = N_i^{-1}, \quad i = 1, 2.$$

The monodromy matrix of Ψ around both of the points $s_1(\check{\mu}, \check{\epsilon})$, $s_2(\check{\mu}, \check{\epsilon})$ is equal to

$$N(\check{\mu}, \check{\epsilon}) = N_1(\check{\mu}, \check{\epsilon})N_2(\check{\mu}, \check{\epsilon}) = \begin{pmatrix} e^{\frac{s_1-s_2}{\sqrt{\check{\epsilon}}}\pi i} & 0 \\ 0 & e^{-\frac{s_1-s_2}{\sqrt{\check{\epsilon}}}\pi i} \end{pmatrix}. \quad (2.3.36)$$

At the limit when $\check{\epsilon} \rightarrow 0$ we get $N(\check{\mu}, 0) = \begin{pmatrix} e^{\frac{1}{\sqrt{\check{\mu}}}\pi i} & 0 \\ 0 & e^{-\frac{1}{\sqrt{\check{\mu}}}\pi i} \end{pmatrix}$, which is for $\mu \neq 0$ the monodromy matrix of Ψ around the double zero $s_1(\check{\mu}, 0) = s_2(\check{\mu}, 0)$, while none of the matrices $N_1(\check{\mu}, \check{\epsilon})$, $N_2(\check{\mu}, \check{\epsilon})$ has a limit. This is the reason for splitting the domain Ω_I into Ω_{I+} , Ω_{I-} and choosing Ψ_{I+} , Ψ_{I-} in the way we did. Therefore, the fundamental solution $\Psi_{I\pm}$ are well defined on the whole $\mathring{\Omega}_{I\pm}$ and Ψ_O is well defined on the whole $\mathring{\Omega}_O$.

Considering now the fundamental solutions $F_\bullet \Psi_\bullet$ of Δ^s (2.3.15) on the ramified (\check{s}, \check{m}) -space, there is a connection matrix whenever a point $(s, m) \in \mathbf{S} \times \mathbf{M}$ is covered more than once: Either there can be two domains $\Omega(\check{\mu}, \check{\epsilon})$ with the same $(\check{\mu}, \check{\epsilon})$, or with two different ramified parameters $(\check{\mu}, \check{\epsilon})$ corresponding to the same (μ, ϵ) . The collection of all these connection matrices carries all the information about the analytic equivalence class of the system Δ .

Proposition 2.3.11. *Let $\Delta(x, m)$, $\Delta'(x, m)$ be two families of parametric systems and let $\Delta^s(s, m)$, $\Delta'^s(s, m)$ be their transforms as in (2.3.15). Let F_\bullet , F'_\bullet be normalizing transformations for Δ^s , Δ'^s :*

$$(F_\bullet)^* \Delta^s = \overline{\Delta}^s = (F'_\bullet)^* \Delta'^s$$

on the domains $\bullet = O, I+, I-$ defined above. If all the connection matrices associated to the fundamental solutions $F_\bullet \Psi_\bullet$ of Δ^s agree with those associated to the fundamental solutions $F'_\bullet \Psi_\bullet$ of Δ'^s , then the two parametric families of systems Δ , Δ' are analytically equivalent.

PROOF. Let $H(s, m) := F'_\bullet(\check{s}, \check{m}) F_\bullet(\check{s}, \check{m})^{-1}$. Since all the connection matrices are equal, H is a well defined non-ramified invertible matrix function defined on the union of the projections of the domains Ω_\bullet to (s, m) -space, $\bullet = O, I+, I-$. It is bounded on a neighborhood of each singularity s_i , hence H can be analytically extended on $(\mathbf{S} \setminus \{0\}) \times \mathcal{M} \times \mathcal{E}$, where $\mathbf{S}, \mathcal{M}, \mathcal{E}$ are as in (2.3.26). It satisfies $H = H^P$: if s is in the projection of $\Omega_\bullet(\check{\mu}, \check{\epsilon})$ and $H(s, \check{m}) = F'_\bullet(\check{s}, \check{m}) F_\bullet(\check{s}, \check{m})^{-1}$ then $-s$ is in the projection of Ω_\bullet^P and

$$\begin{aligned} H(-s, \check{m}) &= F_\bullet^P(e^{\pi i} \check{s}, \check{m}) (F_\bullet^P(e^{\pi i} \check{s}, \check{m}))^{-1} = \\ &= \begin{pmatrix} 0 & 1 \\ 1 & 0 \end{pmatrix} F'_\bullet(\check{s}, \check{m}) F_\bullet(\check{s}, \check{m})^{-1} \begin{pmatrix} 0 & 1 \\ 1 & 0 \end{pmatrix} = \\ &= \begin{pmatrix} 0 & 1 \\ 1 & 0 \end{pmatrix} H(\check{s}, \check{m}) \begin{pmatrix} 0 & 1 \\ 1 & 0 \end{pmatrix}. \end{aligned}$$

Hence the function

$$G(x, m) := S(s, m) V H(s, m) V^{-1} S^{-1}(s, m),$$

with S, V as in (2.3.14), is well defined. The fundamental solutions $\Phi_\bullet(\check{x}, \check{m}) = S(s) V F_\bullet(\check{s}, \check{m}) \Psi_\bullet(\check{s}, \check{m})$ (resp. $\Phi'_\bullet(\check{x}, \check{m}) = S(s) V F'_\bullet(\check{s}, \check{m}) \Psi_\bullet(\check{s}, \check{m})$) of the systems $\Delta(x, m)$ (resp. $\Delta'(x, m)$) can for $\mu^2 \neq \epsilon$ be analytically extended on a neighborhood of the point $x = -\mu$ (i.e. $s = 0$) which is non-singular for these systems. As $G = \Phi'_\bullet \Phi_\bullet^{-1}$, it means that $G^* \Delta' = \Delta$ and that G is an invertible analytic matrix function on $(\mathbf{X} \times \mathbf{M}) \setminus \{x = -\mu, \epsilon = \mu^2\}$, where

$$\mathbf{X} := \{|x| \leq \delta_s^2 - \delta_\mu\}.$$

Since the problematic points are in a set of codimension 2, G is analytic on the whole neighborhood $X \times M$ of 0. \square

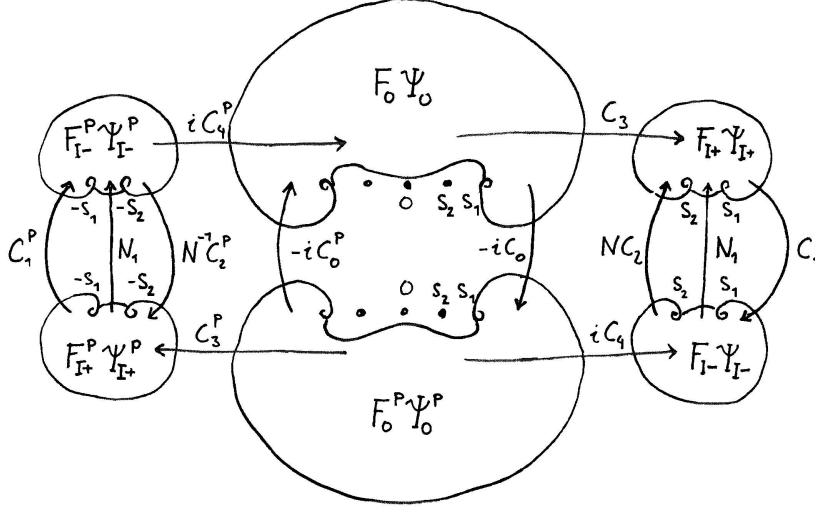

FIGURE 2.10. The connection matrices between the fundamental solutions $F_{\bullet} \Psi_{\bullet}$ for a fixed parameter $(\check{\mu}, \check{\epsilon})$, $\check{\mu}^2 \neq \check{\epsilon}$. For $\check{\mu}^2 = \check{\epsilon}$, only the fundamental solutions $F_O \Psi_O$ and $F_O^P \Psi_O^P$ persist, with the two corresponding connection matrices $-iC_0, -iC_0^P$. (Picture with $(\check{\mu}, \check{\epsilon})$ as in Figures 2.9 and 2.7(a)).

Lemma 2.3.12. *Let F_{\bullet} be the normalizing transformations from Proposition 2.3.7 satisfying (2.3.34) with the uniquely determined functions κ_{\bullet} , and let Ψ_{\bullet} be as Figure 2.9. Then for each fixed $\check{m} \in M$ the connection matrices between the solutions $F_{\bullet} \Psi_{\bullet}$ on the domains $\Omega_{\bullet}(\check{\mu}, \check{\epsilon})$ are given in Figure 2.10 with the matrices $C_0(\check{m}), \dots, C_4(\check{m})$ equal to*

$$\begin{aligned} C_0 &= \begin{pmatrix} 1 & i\gamma \\ 0 & 1 \end{pmatrix}, & C_3 &= \begin{pmatrix} 1 & i\kappa^{-1}e^{-2a\pi i} \\ 0 & \kappa^{-1} \end{pmatrix}, \\ C_1 &= \begin{pmatrix} 1 & i\kappa^{-1}(\gamma - e^{2a\pi i} - e^{-2a\pi i}) \\ 0 & 1 \end{pmatrix}, & C_4 &= \begin{pmatrix} 1 & -i\kappa^{-1}e^{2a\pi i} \\ 0 & \kappa^{-1} \end{pmatrix}, \\ C_2 &= \begin{pmatrix} 1 & 0 \\ -i\kappa e^{2a\pi i} & 1 \end{pmatrix}, \end{aligned} \quad (2.3.37)$$

where

$$a(\check{m}) := \begin{cases} \frac{s_1(\check{\mu}, \check{\epsilon}) - s_2(\check{\mu}, \check{\epsilon})}{2\sqrt{\check{\epsilon}}} & \text{if } \check{\epsilon} \neq 0, \\ \frac{1}{2\sqrt{\check{\mu}}} & \text{if } \check{\epsilon} = 0 \text{ and } \check{\mu} \neq 0, \end{cases} \quad (2.3.38)$$

$$\kappa(\check{m}) := \frac{\kappa_O(\check{m})}{\kappa_I(\check{m})} \quad (2.3.39)$$

and $\gamma(m)$, the analytic invariant of the system $\Delta(x, m)$, is the trace of monodromy.

PROOF. From Lemma 2.3.8 we know that a connection matrix on an intersection domain that is adjacent to point $s_1(\check{\mu}, \check{\epsilon})$ (resp. $s_2(\check{\mu}, \check{\epsilon})$) must be upper triangular (resp. lower triangular), with the diagonal terms determined by the values of the corresponding pair of transformations $F_{\bullet}(s_1(\check{\mu}, \check{\epsilon}), \check{m})$ (resp. $F_{\bullet}(s_2(\check{\mu}, \check{\epsilon}), \check{m})$). Hence we have

$$C_0 = \begin{pmatrix} 1 & c_0 \\ 0 & 1 \end{pmatrix}, \quad C_1 = \begin{pmatrix} 1 & c_1 \\ 0 & 1 \end{pmatrix}, \quad C_2 = \begin{pmatrix} 1 & 0 \\ c_2 & 1 \end{pmatrix}, \quad C_3 = \begin{pmatrix} 1 & c_3 \\ 0 & \kappa^{-1} \end{pmatrix}, \quad C_4 = \begin{pmatrix} 1 & c_4 \\ 0 & \kappa^{-1} \end{pmatrix},$$

for some $c_0(\check{m}), \dots, c_4(\check{m})$.

Let $M(\check{m})$ be the monodromy matrix of the fundamental solution

$$\Phi_O(\check{x}, \check{m}) = S(s) V F_O(\check{s}, \check{m}) \Psi_O(\check{s}, \check{\mu}, \check{\epsilon})$$

of the system Δ around the two singular points $x = \pm\sqrt{\check{\epsilon}}$ in the positive direction. On the one hand we have

$$\begin{aligned} M &= \Psi_O(\check{s})^{-1} F_O(\check{s})^{-1} V^{-1} S(s)^{-1} \cdot S(-s) V F_O(e^{\pi i} \check{s}) \Psi_O(e^{\pi i} \check{s}) \\ &= \Psi_O(\check{s})^{-1} F_O(\check{s})^{-1} V^{-1} S(s)^{-1} \cdot S(s) V F_O^P(\check{s}) \Psi_0^P(\check{s}) \begin{pmatrix} 0 & 1 \\ 1 & 0 \end{pmatrix} = -i C_0 \begin{pmatrix} 0 & 1 \\ 1 & 0 \end{pmatrix}. \end{aligned}$$

On the other hand, as apparent from Figure 2.10,

$$M = C_3 C_1 N C_2 C_3^{-1},$$

where $N = \begin{pmatrix} e^{2a\pi i} & 0 \\ 0 & e^{-2a\pi i} \end{pmatrix}$. Therefore

$$\begin{aligned} -i C_0 \begin{pmatrix} 0 & 1 \\ 1 & 0 \end{pmatrix} &= C_3 C_1 N C_2 C_3^{-1} = M, \\ \begin{pmatrix} -i c_0 & -i \\ -i & 0 \end{pmatrix} &= \begin{pmatrix} e^{2a\pi i} + e^{-2a\pi i} c_2 (c_1 + c_3) & \kappa e^{-2a\pi i} (c_1 + c_3) (1 - c_2 c_3) - \kappa e^{2a\pi i} c_3 \\ \kappa^{-1} e^{-2a\pi i} c_2 & e^{-2a\pi i} (1 - c_2 c_3) \end{pmatrix}, \end{aligned}$$

which implies that

$$\gamma = \text{tr} M = -i c_0 = e^{2a\pi i} + e^{-2a\pi i} + e^{-2a\pi i} c_1 c_2, \quad (2.3.40)$$

$$c_2 c_3 = 1, \quad \text{and} \quad c_2 = -i \kappa e^{2a\pi i}, \quad c_3 = i \kappa^{-1} e^{-2a\pi i}.$$

From Figure 2.10 one also sees that

$$C_3 C_1 = C_0 C_4,$$

which gives the matrix C_4 . □

The matrices $C_0(\check{m}), \dots, C_4(\check{m})$ of Lemma 2.3.12 determine for each fixed $\check{m} \in \check{M}$ all the relations between the set of fundamental solutions $F_{\bullet}(\cdot, \check{m})$, $\bullet = O, I+, I-$ and their symmetric counterparts $F_{\bullet}^P(\cdot, \check{m})$. We will now look at the situation of two

different $\check{m} \in \check{\mathbb{M}}$ corresponding to the same value of m . One finds that the corresponding connection matrices can be expressed in terms of the values of C_0, \dots, C_4 for the two ramified parameters, while certain cocycle relations must be satisfied.

Lemma 2.3.13. *Let F_\bullet, Ψ_\bullet be as in Lemma 2.3.12. We will use the following kind of notation: If $\bar{m}, \bar{\bar{m}} \in \check{\mathbb{M}}$ (resp. $\tilde{m}, \tilde{\tilde{m}} \in \check{\mathbb{M}}$) are two values of the ramified parameter \check{m} , we write $\bar{X} = X(\bar{m})$, $\bar{\bar{X}} = X(\bar{\bar{m}})$ (resp. $\tilde{X} = X(\tilde{m})$, $\tilde{\tilde{X}} = X(\tilde{\tilde{m}})$) for any object X depending on \check{m} .*

(a) *Let $\bar{m}, \bar{\bar{m}} \in \check{\mathbb{M}}$ be two values of the ramified parameter that project to the same m , such that*

$$\bar{\epsilon} = \bar{\bar{\epsilon}} =: \check{\epsilon} \quad \text{and} \quad \bar{\mu} - \sqrt{\check{\epsilon}} = e^{2\pi i}(\bar{\mu} - \sqrt{\check{\epsilon}}),$$

i.e. $\bar{\mu}$ is $\bar{\mu}$ plus one positive turn around the ramification point $\sqrt{\check{\epsilon}}$ in $\check{\mathcal{M}}(\check{\epsilon})$. So

$$\bar{\bar{s}}_1 = \bar{s}_1, \quad \bar{\bar{s}}_2 = e^{\pi i} \bar{s}_2.$$

Hence

$$\bar{\bar{\Omega}}_O = \bar{\Omega}_O, \quad \bar{\bar{F}}_O = \bar{F}_O, \quad \bar{\bar{\Psi}}_O = \bar{\Psi}_O,$$

and we have

$$\bar{\bar{\kappa}}_O = \bar{\kappa}_O = \frac{\bar{\bar{\kappa}} \bar{\kappa}}{1 - e^{-2\frac{\bar{s}_2}{\sqrt{\check{\epsilon}}}\pi i}}. \quad (2.3.41)$$

(b) *Let $\tilde{m}, \tilde{\tilde{m}} \in \check{\mathbb{M}}$ be two values of the ramified parameter that project to the same m such that*

$$(\tilde{\mu}, \tilde{\epsilon}) = e^{2\pi i}(\tilde{\mu}, \tilde{\epsilon}),$$

or more precisely, for $|\mu| \gg \sqrt{|\epsilon|}$, $(\tilde{\mu}, \tilde{\epsilon})$ is obtained from (μ, ϵ) by simultaneously turning both $\check{\epsilon}$ and $\check{\mu}$. So

$$\tilde{\bar{s}}_1 = e^{\pi i} \bar{s}_2, \quad \tilde{\bar{s}}_2 = e^{\pi i} \bar{s}_1, \quad \text{and} \quad \tilde{\bar{N}} = \bar{N}^{-1}.$$

Hence

$$\begin{aligned} \tilde{\bar{\Omega}}_{I+} &= \tilde{\bar{\Omega}}_{I-}^P, & \tilde{\bar{F}}_{I+} &= \tilde{\bar{F}}_{I-}^P, & \tilde{\bar{\Psi}}_{I+} &= -i \tilde{\bar{\Psi}}_{I-}^P, \\ \tilde{\bar{\Omega}}_{I-} &= \tilde{\bar{\Omega}}_{I+}^P, & \tilde{\bar{F}}_{I-} &= \tilde{\bar{F}}_{I+}^P, & \tilde{\bar{\Psi}}_{I-} &= -i \tilde{\bar{\Psi}}_{I+}^P \tilde{\bar{N}}^{-1}. \end{aligned}$$

Therefore

$$\tilde{\bar{C}}_1 = \tilde{\bar{N}}^{-1} \tilde{\bar{C}}_2^P \tilde{\bar{N}}, \quad \tilde{\bar{C}}_2 = \tilde{\bar{C}}_1^P, \quad (2.3.42)$$

and we have

$$\tilde{\bar{\kappa}}_I = \tilde{\bar{\kappa}}_I, \quad (2.3.43)$$

$$\gamma = e^{2\check{a}\pi i} + e^{-2\check{a}\pi i} - \tilde{\bar{\kappa}} \tilde{\bar{\kappa}} e^{-2\check{a}\pi i}, \quad (2.3.44)$$

where \check{a} and $\check{\kappa}$ are defined in (2.3.38) and (2.3.39), and $\check{a} = -\check{a}$.

PROOF. (a) For each $\check{\epsilon} \in \check{\mathcal{E}}$ the ramification of the $\check{\mu}$ -parameter domain $\check{\mathcal{M}}(\check{\epsilon})$ corresponds to the bifurcation $\Sigma_I(\epsilon)$: the difference between $(\bar{\mu}, \check{\epsilon})$ and $(\check{\mu}, \check{\epsilon})$ is that of crossing the line $\Sigma_I(\epsilon)$. Since this bifurcation affects only the inner regions of the field χ , it therefore affects only the internal domains $\Omega_{I\pm}$, $\Omega_{I\pm}^P$, while the outer domains are not affected. Therefore $\bar{\bar{\Omega}}_O = \bar{\Omega}_O$ and consequently $\bar{\bar{F}}_O = \bar{F}_O$.

To obtain the assertion (2.3.41), it is enough to prove it for generic values of (μ, ϵ) , and extend it to the other values by continuity. So we can assume that $\epsilon \neq 0$, $\mu^2 \neq \epsilon$ and moreover that both of the points $s_1(\check{\mu}, \check{\epsilon})$, $s_2(\check{\mu}, \check{\epsilon})$ are non-resonant. In that case, aside from the transformations $F_\bullet(\check{s}, \check{m})$, $\bullet = O, I+, I-$, we have also unique local normalizing transformations $F_i(\check{s}, \check{m})$ defined on a neighborhood $\Omega_i(\check{\mu}, \check{\epsilon})$, $i = 1, 2$, of $s_i(\check{\mu}, \check{\epsilon})$ not containing any other singularity $s_j(\check{\mu}, \check{\epsilon})$ nor the origin, with $F_i(\check{s}_i(\check{\mu}, \check{\epsilon}), \check{m}) = I$. They satisfy

$$\bar{\bar{F}}_1 = \bar{F}_1, \quad \bar{\bar{F}}_2 = \bar{F}_2^P.$$

Let A_i be the connection matrix between $F_i\Psi_{I+}$ and $F_{I+}\Psi_{I+}$:

$$F_{I+}\Psi_{I+} = F_i\Psi_{I+}A_i,$$

see Figure 2.11. It is easy to see that the monodromy of $F_{I+}\Psi_{I+}$ around the point s_1 (resp. s_2) is equal to

$$C_1N_1 = A_1^{-1}N_1A_1, \quad (\text{resp. } N_2C_2 = A_2^{-1}N_2A_2),$$

from which one can calculate using Lemma 2.3.12 that

$$A_1 = \begin{pmatrix} 1 & \frac{1}{e_1^2-1}c_1 \\ 0 & \kappa_I \end{pmatrix}, \quad A_2 = \begin{pmatrix} \kappa_I & 0 \\ \frac{1}{1-e_2^{-2}}c_2 & 1 \end{pmatrix}, \quad (2.3.45)$$

with

$$e_1(\check{\mu}, \check{\epsilon}) := e^{\frac{s_1(\check{\mu}, \check{\epsilon})}{\sqrt{\check{\epsilon}}}\pi i}, \quad e_2(\check{\mu}, \check{\epsilon}) := e^{\frac{s_2(\check{\mu}, \check{\epsilon})}{\sqrt{\check{\epsilon}}}\pi i},$$

and $c_1 = i\kappa^{-1}(\gamma - \frac{e_1}{e_2} - \frac{e_2}{e_1})$, and $c_2 = -i\kappa\frac{e_1}{e_2}$.

Knowing that $\bar{\bar{F}}_2 = \bar{F}_2^P$ one can see from Figure 2.11 that

$$\bar{\bar{A}}_2\bar{\bar{C}}_3^{-1} = \bar{N}_1^{-1}\bar{A}_2^P(\bar{N}_1^P)^{-1}(\bar{C}_4^P)^{-1},$$

where $(\bar{N}_1^P)^{-1} = \bar{N}_1$, i.e.

$$\begin{pmatrix} \bar{\kappa}_I & -i\bar{\kappa}_I\frac{\bar{e}_2}{\bar{e}_1} \\ i\bar{\kappa}\frac{\bar{e}_1\bar{e}_2}{1-\bar{e}_2} & \bar{\kappa}\frac{1}{1-\bar{e}_2} \end{pmatrix} = \begin{pmatrix} \bar{\kappa}\frac{\bar{e}_2}{\bar{e}_2-\bar{e}_2^{-1}} & -i\bar{\kappa}\frac{\bar{e}_1^{-1}}{\bar{e}_2-\bar{e}_2^{-1}} \\ i\bar{\kappa}_I\frac{\bar{e}_1}{\bar{e}_2} & \bar{\kappa}_I \end{pmatrix} \quad (2.3.46)$$

This is satisfied if and only if

$$\bar{\kappa}_I\bar{\kappa}_I = \kappa_O\frac{\bar{e}_2}{\bar{e}_2-\bar{e}_2^{-1}},$$

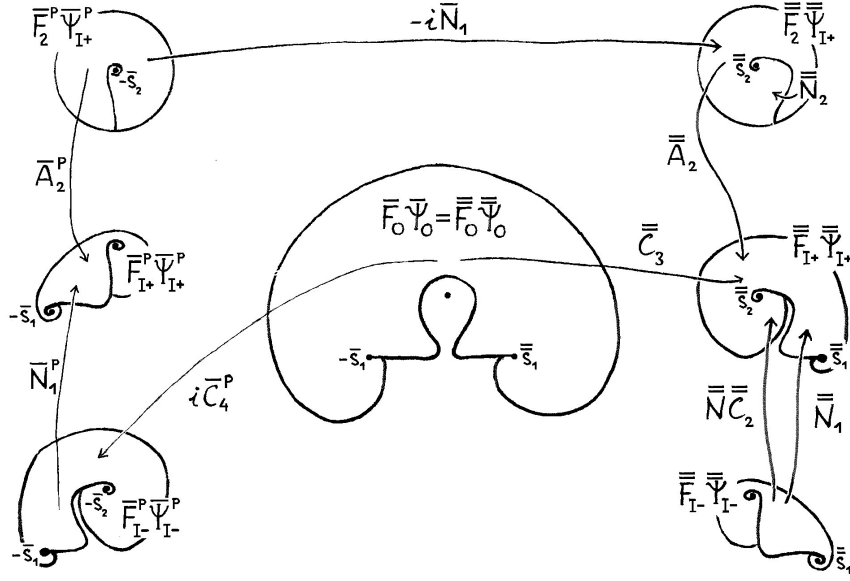

FIGURE 2.11. Connection matrices between fundamental solutions $F_\bullet \Psi_\bullet$ of Lemma 2.3.12, with $\check{\epsilon}$ fixed and $\check{\mu} \neq \bar{\mu}$. (Picture with $\arg \check{\epsilon} = 0$.) The corresponding diagram for the diagonal solutions Ψ_\bullet of $\bar{\Delta}^s$ is obtained by erasing all the F 's and replacing the matrices A_i, C_i by identity matrices. The top arrow in the diagram here $\bar{F}_2^P \bar{\Psi}_{I+}^P \xrightarrow{-i\bar{N}_1} \bar{F}_2^P \bar{\Psi}_{I+}^P$ follows from the corresponding arrow $\bar{\Psi}_{I+}^P \xrightarrow{-i\bar{N}_1} \bar{\Psi}_{I+}^P$ which one can easily read in the corresponding diagram for the diagonal solutions.

which is equivalent to (2.3.41). Similarly, one would find that

$$\bar{A}_1 \bar{C}_3^{-1} = \bar{A}_1 \bar{C}_3^{-1},$$

which is satisfied without imposing any new condition, since

$$A_1 C_3^{-1} = \begin{pmatrix} 1 & \frac{i\gamma e_1^{-1} - ie_2 - ie_2^{-1}}{e_1 - e_1^{-1}} \\ 0 & \kappa_O \end{pmatrix}.$$

(b) Similarly to (a), the passage between $(\check{\mu}, \check{\epsilon})$, $\check{\mu} \in \check{\mathcal{M}}(\check{\epsilon})$, and $(\tilde{\mu}, \tilde{\epsilon}) = e^{2\pi i}(\check{\mu}, \check{\epsilon})$, $\tilde{\mu} \in \check{\mathcal{M}}(\tilde{\epsilon})$, is that of crossing the curve $\Sigma_O(\epsilon)$, which affects only the outer regions, and hence the outer domains. The inner domains rotate together with their vertices $s_1(\check{\mu}, \check{\epsilon})$, $s_2(\check{\mu}, \check{\epsilon})$, therefore $\tilde{\Omega}_{I+} = \tilde{\Omega}_{I-}^P$ and $\tilde{\Omega}_{I-} = \tilde{\Omega}_{I+}^P$. So we have

$$\tilde{F}_{I+} = \tilde{F}_{I-}^P, \quad \tilde{F}_{I-} = \tilde{F}_{I+}^P.$$

One can see from Figure 2.12 that the fundamental solutions $\Psi_{I\pm}$ of the diagonal system $\bar{\Delta}^s$ satisfy

$$\tilde{\Psi}_{I+} = -i \tilde{\Psi}_{I-}^P, \quad \tilde{\Psi}_{I-} = -i \tilde{\Psi}_{I+}^P \tilde{N}.$$

This then implies (2.3.42), i.e.

$$\begin{aligned}\tilde{C}_1 &= \begin{pmatrix} 1 & -i\tilde{\kappa}e^{-2\tilde{a}\pi i} \\ 0 & 1 \end{pmatrix}, & \tilde{\tilde{C}}_1 &= \begin{pmatrix} 1 & -i\tilde{\kappa}e^{2\tilde{a}\pi i} \\ 0 & 1 \end{pmatrix}, \\ \tilde{C}_2 &= \begin{pmatrix} 1 & 0 \\ -i\tilde{\kappa}e^{2\tilde{a}\pi i} & 1 \end{pmatrix}, & \tilde{\tilde{C}}_2 &= \begin{pmatrix} 1 & 0 \\ -i\tilde{\kappa}e^{-2\tilde{a}\pi i} & 1 \end{pmatrix},\end{aligned}$$

as $\tilde{\tilde{a}} = -\tilde{a}$. Then (2.3.44) follows from (2.3.40).

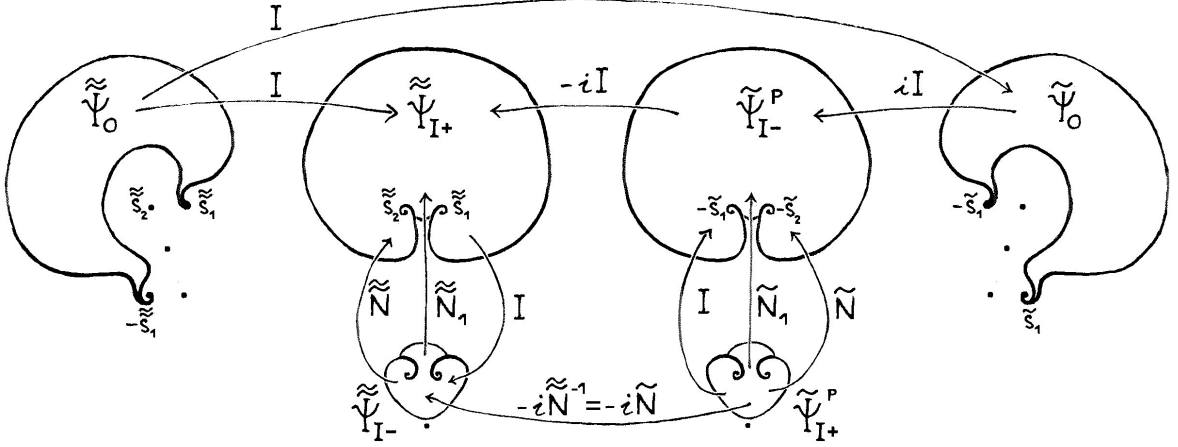

FIGURE 2.12. Connection matrices between fundamental solutions Ψ_\bullet of Lemma 2.3.12 with $(\tilde{\mu}, \tilde{\epsilon}) = e^{2\pi i}(\mu, \epsilon)$.

□

All the connection matrices between the fundamental solutions $F_\bullet \Psi_\bullet$ can now be determined from Lemmas 2.3.12 and 2.3.13.

Proposition 2.3.14. (a) Let Δ be a parametric system, Δ^s its transform (2.3.15), let F_\bullet be the normalizing transformations from Proposition 2.3.7 determined by the condition (2.3.34) and let Ψ_\bullet be as in Figure 2.9. The collection of all the connection matrices between the fundamental solutions $F_\bullet \Psi_\bullet$ is uniquely determined by $\kappa = \frac{\kappa_O}{\kappa_I}$ and by the invariant γ , satisfying the relation (2.3.44).

(b) Let $\gamma(m)$ be a germ of analytic function and assume that there exists an analytic germ $Q(m)$ such that $\gamma = 2 \cos 2\pi Q$. Let $a(\check{\mu}, \check{\epsilon})$ be as in (2.3.38) and

$$b(\check{\mu}, \check{\epsilon}) := \frac{s_1 + s_2}{2\sqrt{\check{\epsilon}}}.$$

Then any triple of functions $\kappa_I, \kappa_O, \kappa = \frac{\kappa_O}{\kappa_I} \in \mathcal{B}(\check{M})$ with $\kappa_O(\check{m}) = 1$ if $(\check{\mu}, \check{\epsilon}) = 0$ and $\kappa_I(\check{m}) = 1$ if $\check{\epsilon} = 0, \check{\mu} \in \check{M}(0)$, satisfying the relations (2.3.41), (2.3.43) and (2.3.44) of Lemma 2.3.13 are equal to

$$\kappa_I = \frac{\sqrt{\frac{s_1 s_2}{\check{\epsilon}}} \Gamma\left(\frac{s_1}{\sqrt{\check{\epsilon}}}\right) \Gamma\left(\frac{s_2}{\sqrt{\check{\epsilon}}}\right)}{\Gamma(1+b-Q) \Gamma(b+Q)} e^{2b \log b - \frac{s_1}{\sqrt{\check{\epsilon}}} \log \frac{s_1}{\sqrt{\check{\epsilon}}} - \frac{s_2}{\sqrt{\check{\epsilon}}} \log \frac{s_2}{\sqrt{\check{\epsilon}}} + f_I}, \quad (2.3.47)$$

$$\kappa_O = 2\pi \frac{\Gamma(\frac{s_1}{\sqrt{\epsilon}}) \Gamma(1 + \frac{s_1}{\sqrt{\epsilon}})}{\Gamma(1+a-Q) \Gamma(1+b-Q) \Gamma(a+Q) \Gamma(b+Q)} e^{2a \log a + 2b \log b - 2\frac{s_1}{\sqrt{\epsilon}} \log \frac{s_1}{\sqrt{\epsilon}} + f_O}, \quad (2.3.48)$$

$$\kappa = 2\pi \frac{\sqrt{\frac{s_1}{s_2}} \Gamma(\frac{s_1}{\sqrt{\epsilon}}) \Gamma(\frac{s_2}{\sqrt{\epsilon}})^{-1}}{\Gamma(1+a-Q) \Gamma(a+Q)} e^{2a \log a - \frac{s_1}{\sqrt{\epsilon}} \log \frac{s_1}{\sqrt{\epsilon}} + \frac{s_2}{\sqrt{\epsilon}} \log \frac{s_2}{\sqrt{\epsilon}} + f}, \quad (2.3.49)$$

where Γ is the gamma function and

$$f = (s_1 + s_2) g(s_1 s_2, s_1^2 + s_2^2), \quad f_I = (s_1 - s_2) g(-s_1 s_2, s_1^2 + s_2^2), \quad f_O = f + f_I,$$

for a unique analytic germ g .

PROOF. (a) All the connection matrices between the fundamental solutions $F_\bullet \Psi_\bullet$ can be determined from Lemmas 2.3.12 and 2.3.13.

(b) Denote $\sigma : \tilde{m} \mapsto \bar{\tilde{m}}$ the continuation map from Lemma 2.3.13 (a), and $\rho : \tilde{m} \mapsto \tilde{\tilde{m}}$ the continuation map from Lemma 2.3.13 (b). Hence,

$$s_1 \circ \sigma = s_1, \quad s_2 \circ \sigma = e^{\pi i} s_2, \quad a \circ \sigma = b, \quad b \circ \sigma = a,$$

$$s_1 \circ \rho = e^{\pi i} s_2, \quad s_2 \circ \rho = e^{\pi i} s_1, \quad a \circ \rho = e^{-\pi i} a, \quad b \circ \rho = b.$$

One can easily verify that the functions $\kappa_I, \kappa_O, \kappa$ of (2.3.47)–(2.3.49) satisfy $\kappa = \frac{\kappa_O}{\kappa_I}$ and the identities

$$(2.3.41) : \quad \kappa_O \circ \sigma = \kappa_O = \frac{\kappa(\kappa \circ \sigma) e^{\frac{s_2}{\sqrt{\epsilon}} \pi i}}{2i \sin \frac{s_2}{\sqrt{\epsilon}} \pi},$$

$$(2.3.43) : \quad \kappa_I \circ \rho = \kappa_I,$$

$$(2.3.44) : \quad 2 \cos 2\pi Q = 2 \cos 2\pi a - \kappa(\kappa \circ \rho) e^{-2a\pi i},$$

using the standard reflection formula $\Gamma(z)\Gamma(1-z) = \frac{\pi}{\sin \pi z}$. It follows from the Stirling formula:

$$\Gamma(1+z) \sim \sqrt{2\pi z} \left(\frac{z}{e}\right)^z \left(1 + O\left(\frac{1}{z}\right)\right) \quad \text{in the sector at infinity where} \\ |\arg z| < \eta \quad \text{for any } 0 < \eta < \pi,$$

that $\lim_{\epsilon \rightarrow 0} \kappa_I(\tilde{m}) = 1$ and $\lim_{(\tilde{m}, \epsilon) \rightarrow 0} \kappa_O(\tilde{m}) = 1$ with the limits being inside \tilde{M} .

On the other hand if $\kappa_I, \kappa_O, \kappa$ are some functions satisfying the assumptions of the proposition, let $\kappa'_I, \kappa'_O, \kappa'$ be given by (2.3.47)–(2.3.49) with $f_I = f_O = f = 0$, then it follows that the functions

$$f_I := \log \frac{\kappa_I}{\kappa'_I}, \quad f_O := \log \frac{\kappa_O}{\kappa'_O}, \quad f := \log \frac{\kappa}{\kappa'},$$

satisfy

$$f_O = f + f_I, \quad f \circ \sigma = f_I, \quad f_O \circ \sigma = f_O, \quad f_I \circ \rho = f_I, \quad f \circ \rho = -f.$$

This implies, in particular, that $f_O \circ \sigma^2 = f_O = f_O \circ \rho^2$, hence that f_O is non-ramified as a function of (s_1, s_2) , and therefore f_O is an analytic function of (s_1, s_2) . Since one can express $f = \frac{1}{2}(f - f \circ \rho) = \frac{1}{2}(f_O - f_O \circ \rho)$ and $f_I = \frac{1}{2}(f_O + f_O \circ \rho)$, they too are analytic functions of (s_1, s_2) . Moreover $0 = \lim_{\check{\epsilon} \rightarrow 0} f_I = \lim_{s_1 - s_2 \rightarrow 0} f_I$, so we can write

$$f_I = (s_1 - s_2) \cdot g, \quad \text{and} \quad f = (s_1 + s_2) \cdot (g \circ \sigma), \quad f_O = f_I + f,$$

with g that is ρ -invariant, thus an analytic function of $s_1 s_2 = \sqrt{\check{\mu}^2 - \check{\epsilon}}$ and of $s_1^2 + s_2^2 = 2\check{\mu}$, which are algebraically independent and form a Hilbert basis of the space of polynomials of (s_1, s_2) that are invariant to the action of ρ . \square

Corollary 2.3.15. *Two germs of parametric families of systems $\Delta(x, m)$ and $\Delta'(x, m)$ are analytically equivalent by means of a germ of analytic transformation $G(x, m)$ satisfying*

$$G(x, m) = I \quad \text{whenever} \quad x^2 - \epsilon = 0, \quad (2.3.50)$$

if and only if they have the same κ .

PROOF. If G satisfying (2.3.50) is such that $G^* \Delta' = \Delta$, and if $F_\bullet, \bullet = O, I$, are the uniquely determined diagonalizing transformations of Proposition 2.3.7 for Δ^s (2.3.15): $F_\bullet^* \Delta^s = \overline{\Delta}^s$, then $F'_\bullet = V^{-1} S^{-1} G S V F_\bullet$ must be the uniquely determined transformations for Δ'^s , and therefore

$$\kappa_\bullet = \det F_\bullet = \det F'_\bullet = \kappa'_\bullet.$$

Conversely, if $\kappa = \kappa'$, then also $\kappa_O = \kappa'_O$, $\kappa_I = \kappa'_I$ and $\gamma = \gamma'$, which are determined by (2.3.41), (2.3.39) and (2.3.44). Therefore the collections of connection matrices are the same for the two systems (Proposition 2.3.14), and the transformation $G(x, m)$ of the proof of Proposition 2.3.11 has the property (2.3.50). \square

Everything is now ready to finish the proof of Theorem I.

PROOF OF THEOREM I (A). Let $\Delta(x, m), \Delta'(x, m)$ be two parametric families of systems, $\Delta^s(s, m), \Delta'^s(s, m)$ their transforms (2.3.15) and F_\bullet, F'_\bullet be the normalizing transformations from Proposition (2.3.7) determined by the condition (2.3.34) with $\kappa_\bullet, \kappa'_\bullet$. Suppose that their invariants $\gamma = \gamma'$ are the same. We want to show that the two families of systems Δ, Δ' are then analytically equivalent. We know that $\kappa_I(\check{m}) = 1 = \kappa'_I(\check{m})$ when $\check{\epsilon} = 0$, and $\kappa_O(\check{m}) = 1 = \kappa'_O(\check{m})$ when $(\check{\mu}, \check{\epsilon}) = 0$. Let

$\delta(\check{m})$ depending continuously on the parameter $\check{m} \in \check{M}$ be such that

$$\frac{\kappa'_O}{\kappa'_I} = \delta^2 \frac{\kappa_O}{\kappa_I}, \quad \delta(0) = 1.$$

The relation (2.3.44) implies that $\delta(\check{m}) \delta(\tilde{m}) = 1$. Put

$$F''_O = \delta^{-1} F'_O, \quad F''_I = F'_I \begin{pmatrix} \delta^{-1} & 0 \\ 0 & \delta \end{pmatrix}.$$

They are also normalizing transformations for the system Δ'^s : $(F''_\bullet)^* \Delta'^s = \Delta'^s$. It is easily verified that the connection matrices between the fundamental solutions $F''_\bullet \Psi_\bullet$ are exactly the same as those between the fundamental solutions $F_\bullet \Psi_\bullet$ (with Ψ_\bullet as in Figure 2.10), hence one concludes by Proposition 2.3.11. \square

PROOF OF THEOREM IV. (i) For $\epsilon(m) = 0$, the transformation $T_{I,m}^+$ converges to $T_{O,m}$, i.e. $|T_{I,m}^+(s) - T_{O,m}(s)| \rightarrow 0$, $s \in S_{I,m}^+$, if and only if $F_I(\cdot, m)$ converges to $F_O(\cdot, m)$, which happens if and only if the matrix $C_3(m) \rightarrow I$.

(ii) To show that the transformation $T_{2,m}$ converges to $T_{O,m}$, we need to show that the corresponding transformation $F_2(\cdot, m)$ converges to $F_O(\cdot, m)$. It will be enough to show that the difference of fundamental solutions $F_2 \Psi_O - F_O \Psi_O$ converges to 0 for each fixed s . We know from the proof of Lemma 2.3.13 (a), Figure 2.11, that $F_O \Psi_O = F_2 \Psi_O A_2 C_3^{-1}$, where A_2 is given by (2.3.45) and $A_2 C_3^{-1}$ has been calculated in (2.3.46)

$$A_2 C_3^{-1} = \begin{pmatrix} \kappa_I & -i\kappa_I \frac{e_2}{e_1} \\ i\kappa \frac{e_1 e_2}{1-e_2} & \kappa \frac{1}{1-e_2} \end{pmatrix}, \quad \text{where } e_j = e^{\frac{s_j \pi i}{\sqrt{\epsilon}}}, \quad j = 1, 2.$$

We need that $A_2 C_3^{-1} \rightarrow I$, which happens if and only if $\frac{e_2}{e_1} \rightarrow 0$ and $e_1 e_2 \rightarrow 0$ as $\epsilon(m) \rightarrow 0$, i.e. $\text{Im}\left(\frac{s_2 - s_1}{\sqrt{\epsilon}}\right) > 0$ and $\text{Im}\left(\frac{s_2 + s_1}{\sqrt{\epsilon}}\right) > 0$. For $\mu = O(\epsilon)$, we have $s_1 = \epsilon^{\frac{1}{4}} + O(\epsilon^{\frac{3}{4}})$, $s_2 = \pm i\epsilon^{\frac{1}{4}} + O(\epsilon^{\frac{3}{4}})$, hence $\frac{s_2 - s_1}{\sqrt{\epsilon}} = \frac{-1 \mp i}{s_2} + O(\epsilon^{\frac{1}{4}})$, $\frac{s_2 + s_1}{\sqrt{\epsilon}} = \frac{-1 \pm i}{s_2} + O(\epsilon^{\frac{1}{4}})$. Therefore the condition of convergence is satisfied if $\arg s_2 \in (\frac{\pi}{4}, \frac{3\pi}{4})$, i.e. if $\arg x_2 \in (\frac{\pi}{2}, \frac{3\pi}{2})$. \square

Chapter 3

CONFLUENCE OF SINGULARITIES OF NON-LINEAR DIFFERENTIAL EQUATIONS VIA BOREL-LAPLACE TRANSFORMATIONS

Abstract. Borel summable divergent series usually appear when studying solutions of analytic ODE near a multiple singular point. Their sum, uniquely defined in certain sectors of the complex plane, is obtained via the Borel–Laplace transformation. This article shows how to generalize the Borel–Laplace transformation in order to investigate bounded solutions of parameter dependent non-linear differential systems with two simple (regular) singular points unfolding a double (irregular) singularity. We construct parametric solutions on domains attached to both singularities, that converge locally uniformly to the sectoral Borel sums. Our approach provides a unified treatment for all values of the complex parameter.

3.1. INTRODUCTION

When studying solutions of complex analytic ODE near a multiple singular point, it is the general rule to find divergent series. This is explained when considering generic parameter depending deformations which split the multiple singular point into several simple singularities: the local analytic solutions at each singular point of the deformed equation do not match, thus explaining why solutions with nice asymptotic behavior at the limit when the singular points coalesce only exist in sectors. The solutions in these sectors can be found, using the Borel and Laplace transformations, as the Borel sums of the divergent formal solution. Examples of Borel summable (1-summable) divergent power series usually arise as formal solutions of systems of ODEs at a double singular point.

When investigating families of analytic systems of ODEs depending on a complex parameter, that unfold a multiple singularity, we are faced with the problem that the Borel–Laplace method as such does not allow to deal with several singularities and their confluence.

The goal of this article is to show how one can generalize (unfold) the corresponding Borel–Laplace transformations in order to investigate bounded solutions of first order non-linear parametric systems with an unfolded double singularity of the form

$$(x^2 - \epsilon) \frac{dy}{dx} = M(\epsilon)y + f(x, y, \epsilon), \quad (x, y, \epsilon) \in \mathbb{C} \times \mathbb{C}^m \times \mathbb{C}, \quad (3.1.1)$$

with $M(0)$ an invertible $m \times m$ -matrix and $f(x, y, \epsilon) = O(\|y\|^2) + x O(\|y\|) + (x^2 - \epsilon) O(1)$. Such solutions correspond to ramified center manifolds of an unfolded codimension 1 saddle-node singularity in a family of complex vector fields

$$\dot{x} = x^2 - \epsilon, \quad \dot{y} = M(\epsilon)y + f(x, y, \epsilon).$$

It is well known that for generic (non-resonant) values of the parameter $\epsilon \neq 0$, there exists a local analytic solution on a neighborhood of each simple singularity $x = \pm\sqrt{\epsilon}$. Previous studies of the confluence phenomenon (see [SS], [G2]) have focused at the limit behavior of these local solutions when $\epsilon \rightarrow 0$. Because the resonant values of ϵ accumulate at 0 in a finite number of directions, these directions of resonance in the parameter space could not be covered in those studies.

We will construct a new kind of parametric solutions of systems (3.1.1) which are defined and bounded on certain ramified domains attached to both singularities $x = \pm\sqrt{\epsilon}$ (at which they possess a limit) in a spiraling manner. They depend analytically on the parameter ϵ taken from a ramified sector of opening $> 2\pi$ (or $\sqrt{\epsilon}$ from a sector of opening $> \pi$), thus covering a full neighborhood of the origin in the parameter space (including those parameters values for which the unfolded system is resonant), and they converge uniformly when ϵ tends radially to 0 to a pair of the classical sectoral solutions: Borel sums of the formal power series solution of the limit system, defined on two sectors covering a full neighborhood of the double singularity at the origin. In fact, each such pair of the sectoral Borel sums for $\epsilon = 0$ unfolds to a unique above mentioned parametric solution. We state these results in Section 3.2.2, and illustrate them in Section 3.2.3 on the problem of existence of normalizing transformations for families of linear differential systems unfolding a non-resonant irregular singularity of Poincaré rank 1.

While these solutions can also be obtained by other methods, the advantage of our approach is that it provides a unified treatment for all values of the parameter ϵ and elucidates the form of natural domains on which the solutions exist and are bounded. Most importantly, it gives an insight to intrinsic properties of the singularity and to the source of the divergence similar to that provided by the classical Borel–Laplace approach.

3.2. STATEMENT OF RESULTS

Notation 3.2.1. Throughout the text (a, b) (resp. $[a, b]$) denotes the open (resp. closed) oriented segment between two points $a, b \in \mathbb{C}$; $e^{i\alpha}\mathbb{R}^+ = [0, +\infty e^{i\alpha})$ is an oriented ray, and $c + e^{i\alpha}\mathbb{R} = (c - \infty e^{i\alpha}, c + \infty e^{i\alpha})$, with $\alpha \in \mathbb{R}$, $c \in \mathbb{C}$, is an oriented line.

3.2.1. Borel–Laplace transformations and their unfolding

The *Borel method of summation of (1-summable) divergent series* is used to construct their sectoral Borel sums: unique analytic functions that are *asymptotic* to the series in certain sectors of opening $> \pi$ at the singular point and satisfy the same differential relations.

The *formal Borel transform* of a formal power series $\hat{y}(x) = \sum_{k=1}^{+\infty} y_k x^k$ is a series

$$\widehat{B}[\hat{y}](\xi) = \sum_{k=1}^{+\infty} \frac{y_k}{(k-1)!} \xi^{k-1}. \quad (3.2.1)$$

The plane of ξ is also called the *Borel plane*. If the coefficients of $\hat{y}(x)$ have at most factorial growth ($|y_k| \leq c^k k!$ for some $c > 0$), then the series $\widehat{B}[\hat{y}](\xi)$ is convergent on a neighborhood of 0 with a sum $\phi(\xi)$. Now, if ϕ has an analytic extension to a half-line $e^{i\alpha}\mathbb{R}^+$, and has at most exponential growth there ($|\phi(x)| \leq K e^{\Lambda|x|}$, $\xi \in e^{i\alpha}\mathbb{R}^+$, for some $K, \Lambda > 0$), then its *Laplace transform in the direction α*

$$L_\alpha[\phi](x) = \int_0^{+\infty e^{i\alpha}} \phi(\xi) e^{-\frac{\xi}{x}} d\xi \quad (3.2.2)$$

is convergent for x in a small open disc of diameter $\frac{1}{\Lambda}$ centered at $\frac{e^{i\alpha}}{2\Lambda}$ and extends to 0 (which lies on the boundary of the disc), defining there the *Borel sum* of $\hat{y}(x)$ in direction α . A series $\hat{y}[x]$ is called *Borel summable* (or *1-summable*) if its Borel sum exists in all but finitely many directions $0 \leq \alpha < 2\pi$. When varying continuously the direction in which the series is summable, the corresponding Borel sums are analytic extensions one of the other, yielding a function defined on a sector of opening $> \pi$.

Let us remark that $\hat{y}[x]$ is convergent if and only if it is Borel summable in all directions. This means that the Borel sums of divergent series can only exist on sectors. This is also known as the Stokes phenomenon.

Each Borel sum of $\hat{y}(x)$ is asymptotic to the formal series $\hat{y}(x)$ at the origin, and most importantly, if $\hat{y}(x)$ is a formal solution to some analytic differential equation, then so are the Borel sums. More detailed information on the Borel summability can be found, for example, in [MR2] and [Ma2].

A typical source of Borel summable power series are formal solutions of generic ODEs at a double irregular singular point.

Example 3.2.2. A non-linear analytic ODE with a double singularity at the origin

$$x^2 \frac{dy}{dx} = y + f(x, y), \quad (x, y) \in \mathbb{C} \times \mathbb{C}, \quad (3.2.3)$$

where $f(x, y) = O(x) + O(\|y\|^2)$ is a germ of analytic function, possesses a unique formal solution $\hat{y}(x)$. Generically, this series is divergent (for instance if $f(x, y) = -x$ then $\hat{y}(x) = \sum_{n=1}^{+\infty} (n-1)!x^n$ is the Euler series). The reason for the divergence of $\hat{y}(x)$ is materialized by a singularity of the Borel transform $\widehat{B}[\hat{y}](\xi)$ at $\xi = 1$. The Borel sum $y(x) = L_\alpha[\widehat{B}[\hat{y}]](x)$ of $\hat{y}(x)$, $\alpha \in (0, 2\pi)$, is a solution to (3.2.3), well defined in a ramified sector $\arg x \in (-\frac{\pi}{2}, \frac{5\pi}{2})$. The set $(x, y(x))$ is a *center manifold of a saddle-node* singularity of the vector field

$$\dot{x} = x^2, \quad \dot{y} = y + f(x, y).$$

Hence, this example shows that in general an analytic center manifold does not exist, but instead there are “sectoral center manifolds”.

The *analytic Borel transformation in direction α* of a germ of function $y(x)$, which is analytic in a closed sector of opening $\geq \pi$ bisected by $e^{i\alpha}\mathbb{R}^+$ and vanishes at 0 as $O(x^\lambda)$ uniformly in the sector for some $\lambda > 0$, is defined as the “Cauchy principal value” (*V.P.*) of the integral

$$B_\alpha[y](\xi) = \frac{1}{2\pi i} V.P. \int_\gamma y(x) e^{\frac{\xi}{x}} \frac{dx}{x^2}, \quad \text{for } \xi \in e^{i\alpha}\mathbb{R}, \quad (3.2.4)$$

over a circle $\gamma = \{\operatorname{Re}(\frac{e^{i\alpha}}{x}) = C\}$, $C > 0$, inside the sector.

The formal Borel transform (3.2.1) of an analytic germ y vanishing at 0 is related to the analytic one by

$$B_\alpha[y](\xi) = \chi_\alpha^+(\xi) \cdot \widehat{B}[y](\xi), \quad \text{for } \xi \in e^{i\alpha}\mathbb{R}, \quad (3.2.5)$$

where

$$\chi_\alpha^+(\xi) = \begin{cases} 1, & \text{if } \xi \in (0, +\infty e^{i\alpha}), \\ 0, & \text{if } \xi \in (-\infty e^{i\alpha}, 0). \end{cases}$$

The idea of unfolding the Borel–Laplace operators in order to generalize the methods of Borel summability and resurgent analysis to systems with several confluent singularities was initially brought up by Sternin and Shatalov in [SS]. The key lies in appropriate unfolding of the “kernels” $e^{\frac{\xi}{x}} \frac{dx}{x^2}$ and $e^{-\frac{\xi}{x}} d\xi$ of the transformations (3.2.2) and (3.2.4), and in right determination of the paths of integration. The Borel

transformation is designed so that it converts the derivation $x^2 \frac{d}{dx}$ to multiplication by ξ , and we will want to preserve this property.

The complex vector field $x^2 \frac{\partial}{\partial x}$ with a double singularity at the origin is naturally (and universally) unfolded as

$$(x^2 - \epsilon) \frac{\partial}{\partial x}, \quad \epsilon \in \mathbb{C}. \quad (3.2.6)$$

We will associate to it the *unfolded Borel* and *Laplace transformations*

$$\begin{aligned} \mathcal{B}_\alpha^+[y](\xi, \sqrt{\epsilon}) &= \frac{1}{2\pi i} \int_{\operatorname{Re} e^{i\alpha} t(x, \epsilon) = C} y(x) e^{t(x, \epsilon)\xi} dt(x), \quad 0 < C < \operatorname{Re} \left(e^{i\alpha} \frac{\pi i}{\sqrt{\epsilon}} \right), \\ \mathcal{L}_\alpha[\phi](x, \sqrt{\epsilon}) &= \int_{-\infty e^{i\alpha}}^{+\infty e^{i\alpha}} \phi(\xi) e^{-t(x, \epsilon)\xi} d\xi, \end{aligned} \quad (3.2.7)$$

where $t(x, \epsilon)$ is the negative complex time of the vector field (3.2.6),

$$\frac{dx}{dt} = -(x^2 - \epsilon). \quad (3.2.8)$$

Let us remark that the (unilateral) Laplace transformation $L_\alpha[\phi]$ in (3.2.2) is equal to the (bilateral) Laplace transformation $\mathcal{L}_\alpha[\phi]$ with $\epsilon = 0$ and $t(x, 0) = \frac{1}{x}$, if one extends the integrand by 0 for $\xi \in (-\infty e^{i\alpha}, 0)$:

$$L_\alpha[\phi] = \mathcal{L}_\alpha[\chi_\alpha^+ \phi].$$

In Sections 3.3 and 3.4 we will establish some general properties of these transformations based on the classical theory of Fourier and Laplace integrals, and in Section 3.5 we will apply them to study solutions of (3.1.1) in the vicinity of the singular points.

3.2.2. *Center manifold of an unfolded codimension 1 saddle-node type singularity*

An isolated singular point of a holomorphic vector field in \mathbb{C}^{m+1} is of *saddle-node* type if its linearization matrix has exactly one zero eigenvalue; it is of *codimension 1* if the multiplicity of the singular point is 2. In convenient coordinates, such singularity can be written as

$$\dot{x} = x^2, \quad \dot{y} = M_0 y + f_0(x, y), \quad (x, y) \in (\mathbb{C} \times \mathbb{C}^m, 0), \quad (3.2.9)$$

with M_0 an invertible $m \times m$ -matrix and $f_0(x, y) = O(x) + O(\|y\|^2)$ a germ of analytic vector function. We consider a generic family of vector fields in \mathbb{C}^{m+1} depending analytically on a parameter $\epsilon \in (\mathbb{C}, 0)$ unfolding (3.2.9). Such a family is locally

orbitally analytically equivalent to a family of vector fields¹

$$\dot{x} = x^2 - \epsilon, \quad \dot{y} = M(\epsilon)y + f(x, y, \epsilon), \quad (x, y, \epsilon) \in (\mathbb{C} \times \mathbb{C}^m \times \mathbb{C}, 0), \quad (3.2.10)$$

with $M(0) = M_0$ invertible and $f(x, y, \epsilon) = O(\|y\|^2) + xO(\|y\|) + (x^2 - \epsilon)O(1)$ a germ of analytic vector function at the origin of $\mathbb{C} \times \mathbb{C}^m \times \mathbb{C}$, $f(x, y, 0) = f_0(x, y)$.

The vector field (3.2.9) possesses a ramified 1-dimensional center manifold consisting of several sectoral pieces tangent to the x -axis. We will study its parametric unfolding in the family (3.2.10): It is given as a graph of a function $y = y(x, \sqrt{\epsilon})$, ramified at $x = \pm\sqrt{\epsilon}$, satisfying the singular non-linear system of m ordinary differential equations

$$(x^2 - \epsilon) \frac{dy}{dx} = M(\epsilon)y + f(x, y, \epsilon), \quad (x, y, \epsilon) \in \mathbb{C} \times \mathbb{C}^m \times \mathbb{C}. \quad (3.2.11)$$

Proposition 3.2.3 (Formal solution). *The system (3.2.11) possesses a unique solution in terms of a formal power series in (x, ϵ) :*

$$\hat{y}(x, \epsilon) = (x^2 - \epsilon) \sum_{k,j=0}^{+\infty} y_{kj} x^k \epsilon^j, \quad y_{kj} \in \mathbb{C}^m. \quad (3.2.12)$$

PROOF. Write $\hat{y}(x, \epsilon) = (x^2 - \epsilon) \sum_{k,j} y_{kj} x^k \epsilon^j$ and $f(x, y, \epsilon) = (x^2 - \epsilon) \sum_{k,j} f_{0,kj} x^k \epsilon^j + \sum_{|l| \geq 1} \sum_{k,j} f_{l,kj} x^k \epsilon^j y^l$, with $y_{kj}, f_{l,kj} \in \mathbb{C}^m$, and $M(\epsilon) = \sum_j M_j \epsilon^j$. Substituting $\hat{y}(x, \epsilon)$ for y in f and writing $\frac{dy}{dx} = \sum_{k,j} (k+1)(y_{k-1,j} - y_{k+1,j-1}) x^k \epsilon^j$ in (3.2.11), one can then divide by $(x^2 - \epsilon)$ and compare the coefficients of $x^k \epsilon^j$, obtaining a set of equations

$$M_0 y_{kj} = -f_{0,kj} + P_{kj} \{y_{k'j'} \mid k' \leq k, j' \leq j, k' + j' \leq k + j - 1\} - (k+1)y_{k+1,j-1},$$

where P_{kj} is a polynomial in $y_{k'j'}$ without constant term whose coefficients are linear combinations of columns of $M_{j''}$ and $f_{l,k''j''}$, $j'', j''' \leq j$, $k'' \leq k$, $k'' + 2j'' + 2|l| \leq k + 2j$. Recursively with respect to the linear ordering of the indices (k, j) given by:

$$(k', j') < (k, j) \text{ if } k' + j' < k + j \text{ or if } k' + j' = k + j \text{ and } j' < j$$

this uniquely determines all the coefficient vectors y_{kj} . □

Sectoral center manifold and its unfolding.

For $\epsilon = 0$ it is known that the equation (3.2.11) has a unique solution in terms of a 1-summable formal power series $\hat{y}_0(x) = \hat{y}(x, 0)$ (cf. [Br], or [MR1] for $m = 1$). Its formal Borel transform $\widehat{B}[\hat{y}_0](\xi)$ extends analytically on $\Xi_0 := \mathbb{C} \setminus \bigcup_{\lambda \in \text{Spec}(M_0)} [\lambda, +\infty\lambda)$ with singularities at the eigenvalues of M_0 . The series $\hat{y}_0(x)$ is Borel 1-summable

¹See [RT], Proposition 3.1; it is stated and proved for planar vector fields ($m = 1$), but it stays valid for any dimension $m \geq 1$.

in each direction α with $e^{i\alpha}\mathbb{R}^+ \subset \Xi_0$. To each connected component Ω of $\mathbb{C} \setminus \bigcup_{\lambda \in \text{Spec}(M_0)} \lambda\mathbb{R}^+$ in the Borel plane (Figure 3.1) corresponds a unique Borel sum of $\hat{y}_0(x)$, a solution of the equation, defined on a sector in the x -plane of opening $> \pi$ asymptotic to $\hat{y}_0(x)$ (cf. [Mlm]). For each *two opposite components* Ω^+, Ω^- of the Borel plane (i.e. such that $\Omega^+ \cup \Omega^- \cup \{0\}$ contains some straight line $e^{i\alpha}\mathbb{R}$), the two corresponding sectors of summability form a covering of a neighborhood of the origin in the x -plane.

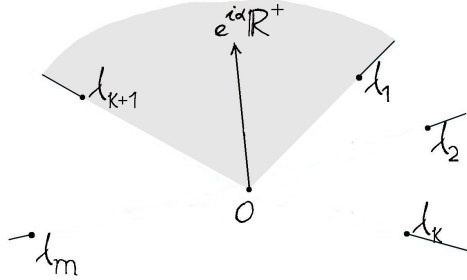

FIGURE 3.1. The rays $\lambda\mathbb{R}^+$, $\lambda \in \text{Spec } M(0)$ divide the Borel plane in sectors. The integration path $e^{i\alpha}\mathbb{R}^+$ of the Laplace transform $L_\alpha[\hat{B}[\hat{y}_0]]$ varies in such sectors.

Theorem 3.2.4 will show that each such covering pair of sectors $\{Z^+(0), Z^-(0)\}$ unfolds for $\epsilon \neq 0$ to a single ramified domain $Z(\sqrt{\epsilon})$, adherent to both singular points $x = \pm\sqrt{\epsilon}$ (see Figure 3.2), on which there exists a unique bounded solution $y(x, \sqrt{\epsilon})$ of (3.2.11), depending analytically on $\sqrt{\epsilon}$ taken from a sector S of opening $> \pi$, that converge uniformly to the two respective Borel sums of $\hat{y}_0(x)$ on $Z^+(0), Z^-(0)$, when $\sqrt{\epsilon} \rightarrow 0$.

Theorem 3.2.4. *Consider a system (3.2.11) with $M(\epsilon)$ a germ of an invertible $m \times m$ -matrix and $f(x, y, \epsilon) = O(\|y\|^2) + xO(\|y\|) + (x^2 - \epsilon)O(1)$ a germ of an analytic function at the origin of $\mathbb{C} \times \mathbb{C}^m \times \mathbb{C}$.*

(i) *To each pair $\{\Omega^+, \Omega^-\}$ of opposite sectoral components of $\mathbb{C} \setminus \bigcup_{\lambda \in \text{Spec}(M(0))} \lambda\mathbb{R}^+$ (i.e. such that $\Omega^+ \cup \Omega^- \cup \{0\}$ contains some straight line $e^{i\alpha}\mathbb{R}$), there exists an associated family of ramified domains $Z(\sqrt{\epsilon})$ parametrized by $\sqrt{\epsilon}$ from a sector S of opening $> \pi$ (see Figure 3.2), and a unique bounded analytic solution $y(x, \sqrt{\epsilon})$ to (3.2.11) that is uniformly continuous on*

$$Z = \{(x, \sqrt{\epsilon}) \mid x \in Z(\sqrt{\epsilon})\}$$

and analytic on the interior of Z and vanishes (is uniformly $O(x^2 - \epsilon)$) at the singular points.

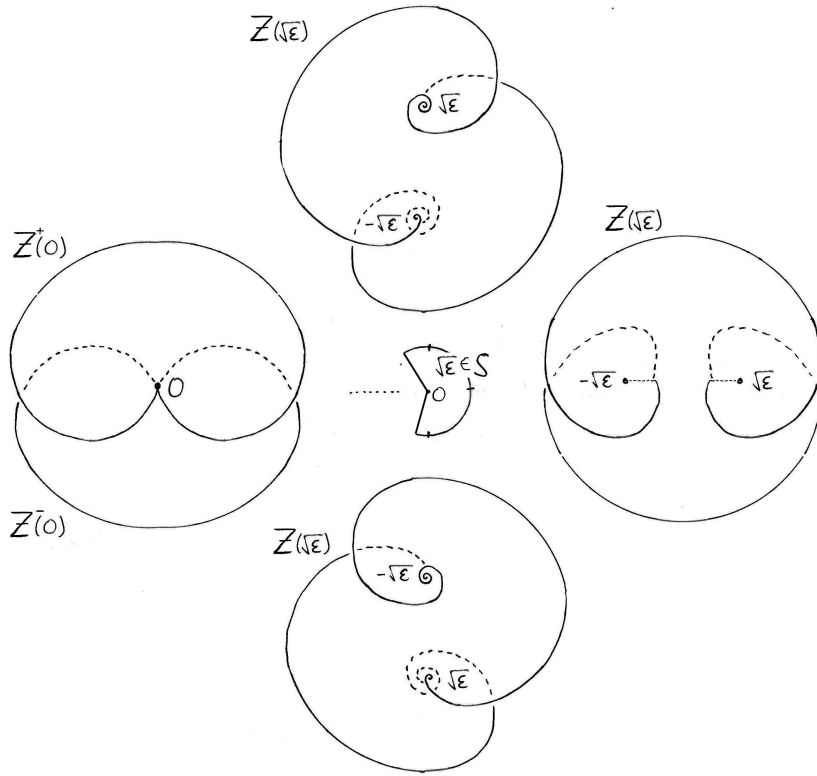

FIGURE 3.2. Example of the spiraling domains $Z(\sqrt{\epsilon})$ of Theorem 3.2.4 (i) according to $\sqrt{\epsilon} \in S$.

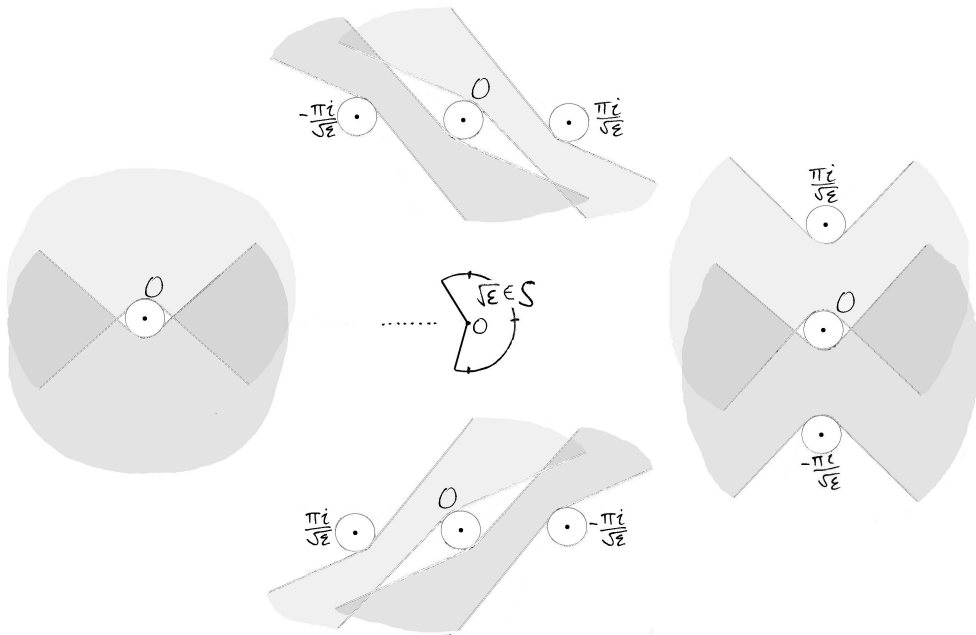

FIGURE 3.3. The domains $Z(\sqrt{\epsilon})$ of Theorem 3.2.4(i) in the time t -coordinate (3.4.1). They are obtained as unions of strips of convergence of the unfolded Laplace transforms $\mathcal{L}_\alpha[\tilde{y}^+](x(t), \sqrt{\epsilon})$ (3.5.21) with varying $\alpha \in (\beta_1, \beta_2) \cap (\arg \sqrt{\epsilon} + \eta, \arg \sqrt{\epsilon} + \pi - \eta)$ (here $\beta_1 \sim \frac{\pi}{4}$, $\beta_2 \sim \frac{3\pi}{4}$).

To be more precise:

- S is a simply connected sectoral domain such that $\nu S \subseteq S$ for any $\nu \in [0, 1]$, and $S \setminus \{0\}$ is open.
- Each $Z(\sqrt{\epsilon})$ is a simply connected ramified set in the x -plane, whose ramification points $\pm\sqrt{\epsilon}$ belong to $Z(\sqrt{\epsilon})$ and are approached from within its interior $Z(\sqrt{\epsilon}) \setminus \{\sqrt{\epsilon}, -\sqrt{\epsilon}\}$ following a logarithmic spiral. The domain $Z(0)$ is composed of two opposing sectoral domains $Z^\pm(0)$ of opening $> \pi$ intersecting at the origin.
- The domains $Z(\sqrt{\epsilon})$ depend continuously on $\sqrt{\epsilon} \in S \setminus \{0\}$ and converge radially to a sub-domain $\lim_{\nu \rightarrow 0^+} Z(\nu\sqrt{\epsilon}) \subseteq Z(0)$, while $Z(0)$ is the union of these radial limits.
- There exists a fixed neighborhood of the origin in the x -plane covered by each domain $Z(\sqrt{\epsilon})$, for each $\sqrt{\epsilon}$ small enough.
- When $\sqrt{\epsilon}$ tends radially to 0, the solution $y(x, \sqrt{\epsilon})$ converges to $y(x, 0)$ uniformly on compact sets of the sub-domain $\lim_{\nu \rightarrow 0^+} Z(\nu\sqrt{\epsilon})$ of $Z(0)$. The restriction of $y(x, 0)$ to $Z^\pm(0)$ is the Borel sum of the formal series $\hat{y}(x, 0)$ (3.2.12) in directions α with $e^{i\alpha}\mathbb{R}^+ \subset \Omega^\pm \cup \{0\}$.
- In the t -coordinate (3.2.8), the domains $Z(\sqrt{\epsilon})$ are simply unions of slanted strips that pass in between discs of radius $\Lambda > 0$ (independent of $\sqrt{\epsilon}$) centered at the points $k\frac{\pi i}{\sqrt{\epsilon}}$, $k \in \mathbb{Z}$, of continuously varying directions $-\alpha + \frac{\pi}{2}$, with $\alpha \in (\beta_1, \beta_2) \cap (\arg \sqrt{\epsilon} + \eta, \arg \sqrt{\epsilon} + \pi - \eta)$, for $\eta > 0$ arbitrarily small and $\beta_1 < \beta_2$ such that the cone $\bigcup_{\beta \in (\beta_1, \beta_2)} e^{i\beta}\mathbb{R}$ is contained in $\Omega^+ \cup \Omega^- \cup \{0\}$ (and hence it does not contain any eigenvalue of $M(\epsilon)$). See Figure 3.3.

The solution $y(x, \sqrt{\epsilon})$, and its domain Z , associated to each pair $\{\Omega^+, \Omega^-\}$ are unique up to the reflection $(x, \sqrt{\epsilon}) \rightarrow (x, -\sqrt{\epsilon})$, and an analytic extension.

(ii) If, moreover, the spectrum of the matrix $M(0)$ is of Poincaré type (the convex hull of $\text{Spec } M(0)$ does not contain 0 inside or on the boundary), i.e. if there exists a (unique) component Ω_1 of $\mathbb{C} \setminus \bigcup_{\lambda \in \text{Spec}(M(0))} \lambda\mathbb{R}^+$ of opening $> \pi$, then the solution $y_1(x, \sqrt{\epsilon})$ on the domain $Z_1(\sqrt{\epsilon})$, $\sqrt{\epsilon} \in S_1$, associated to the pair $\{\Omega_1, \Omega_1\}$ is ramified only at one of the singular points, and analytic at the other (see Figure 3.4).

Such is the case in dimension $m = 1$.

The solutions $y(x, \sqrt{\epsilon})$ will be constructed in Section 3.5.

Remark 3.2.5 (Hadamard–Perron interpretation for $\epsilon \neq 0$). The linearization of the vector field (3.2.10) at $x = \pm\sqrt{\epsilon}$ is equal to

$$\dot{x} = \pm 2\sqrt{\epsilon} \cdot (x \mp \sqrt{\epsilon}), \quad \dot{y} = M(\epsilon) \cdot y. \quad (3.2.13)$$

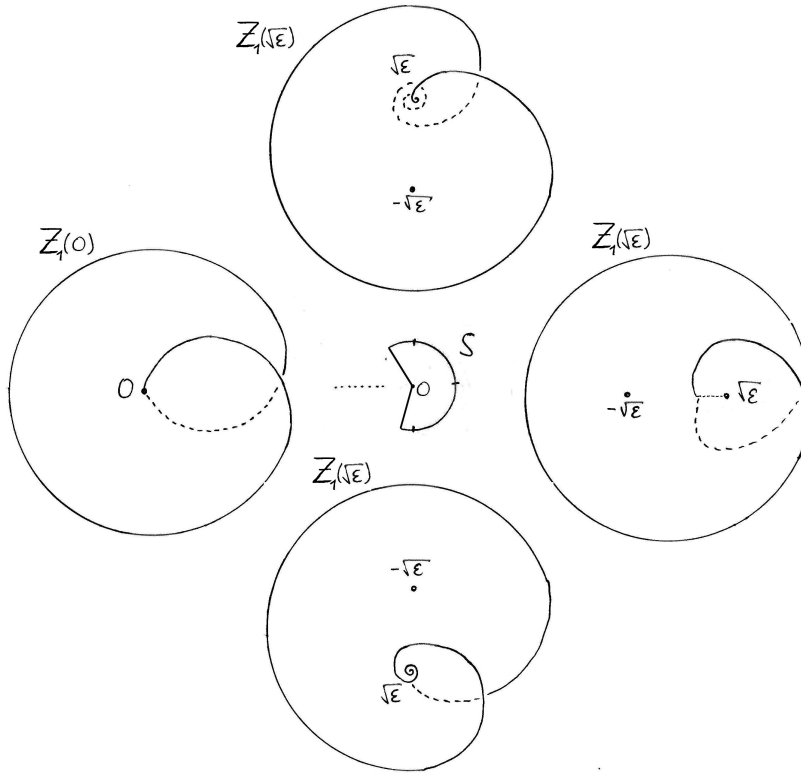

FIGURE 3.4. Example of the spiraling domains $Z_1(\sqrt{\epsilon})$ of Theorem 3.2.4 (ii) according to $\sqrt{\epsilon} \in S_1$.

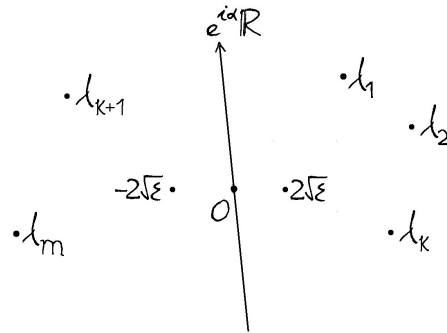

FIGURE 3.5. The spectrum of $M(\epsilon)$ in the Borel plane; the line $e^{i\alpha}\mathbb{R}$ is the dividing line of the Hadamard–Perron theorem and also the integration path of the Laplace transform \mathcal{L}_α (3.5.21).

(i) Let a line $e^{i\alpha}\mathbb{R}$ separate the point $2\sqrt{\epsilon}$ and k of the eigenvalues of $M(\epsilon)$ from the point $-2\sqrt{\epsilon}$ and the other $m - k$ eigenvalues ($0 \leq k \leq m$), see Figure 3.5. Then by the Hadamard–Perron theorem the vector field (3.2.10) has a unique $(k + 1)$ -dimensional local invariant manifold at $(\sqrt{\epsilon}, 0)$, tangent to the x -axis and the corresponding k eigenvectors, and a unique $(m - k + 1)$ -dimensional local invariant manifold at $(-\sqrt{\epsilon}, 0)$, tangent to the x -axis and the corresponding $m - k$ eigenvectors.

They intersect transversally as the graph of the solution $y(x, \sqrt{\epsilon})$ of Theorem 3.2.4. Since the root parameter $\sqrt{\epsilon}$ can vary within the half-plane bounded by the line $e^{i\alpha}\mathbb{R}$, whose angle α can also vary a bit, this gives a sector S of opening $> \pi$. We see that one cannot continue this description in $\sqrt{\epsilon}$ beyond such maximal sector S .

(ii) If all the eigenvalues of $M(\epsilon)$ are in a same open sector of opening $< \pi$ (i.e. $\text{Spec}(M(0))$ is of Poincaré type), and $-2\sqrt{\epsilon}$ lies in the interior of the complementary sector of opening $> \pi$, one obtains the solution $y_1(x, \sqrt{\epsilon})$ from Theorem 3.2.4 as a continuation of the local analytic solution at $x = -\sqrt{\epsilon}$ (i.e. of the local invariant manifold of (3.2.10), tangent to the x -axis, provided by the Hadamard–Perron theorem) to the domain $Z_1(\sqrt{\epsilon})$.

While the Hadamard–Perron approach explains where do the solutions of Theorem 3.2.4 come from, it does not provide their natural domain on which they are bounded. One should however notice the similarities between the description provided by the Hadamard–Perron theorem for $\epsilon \neq 0$ (Figure 3.5) and that of the Borel summation for $\epsilon = 0$ (Figure 3.1). In Section 3.5 we will unify the two of them using the unfolded Borel–Laplace transformations (3.2.7).

Remark 3.2.6 (Local invariant manifolds for non-resonant $\epsilon \neq 0$ and their convergence). If the simple singular point of (3.2.10) at $x = \sqrt{\epsilon} \neq 0$ satisfies the following non-resonance condition

$$2\sqrt{\epsilon}\mathbb{N} \cap \text{Spec } M(\epsilon) = \emptyset,$$

then it is known that the equation (3.2.11) possesses a unique convergent formal solution near $x = \sqrt{\epsilon}$, i.e. the vector field (3.2.10) has a 1-dimensional local analytic invariant manifold tangent to the x -axis at the singularity. The resonant values $\sqrt{\epsilon} = \frac{\lambda}{2n}$, $\lambda \in \text{Spec } M(\epsilon)$, $n \in \mathbb{N}^*$, accumulate at the origin along the rays $\lambda\mathbb{R}^+$, $\lambda \in \text{Spec } M(\epsilon)$, dividing the $\sqrt{\epsilon}$ -plane in a finite number of sectors (Figure 3.6). It has been shown,² that if $\sqrt{\epsilon} \neq 0$ lies in one of these sectors (i.e. $\sqrt{\epsilon}\mathbb{R}^+ \cap \text{Spec } M(0) = \emptyset$), then the local analytic solution at $x = \sqrt{\epsilon}$ converges, when $\sqrt{\epsilon}$ tends radially to 0, to the sectoral Borel sum $L_\alpha[\widehat{B}[\hat{y}_0]](x)$ of the formal solution of the limit system (cf. Figure 3.1), where $\alpha = \arg \sqrt{\epsilon}$ is the direction on which lies the eigenvalue $2\sqrt{\epsilon}$ of the linearization (3.2.13) at $x = \sqrt{\epsilon}$. Unless the spectrum of $M(0)$ is of Poincaré type, these sectors in the $\sqrt{\epsilon}$ -plane, on which the convergence happens, are of opening $< \pi$.

²In [G2] for planar vector fields, $m = 1$, and in [SS] for linear systems; the method of latter can be generalized also for non-linear systems (3.2.11).

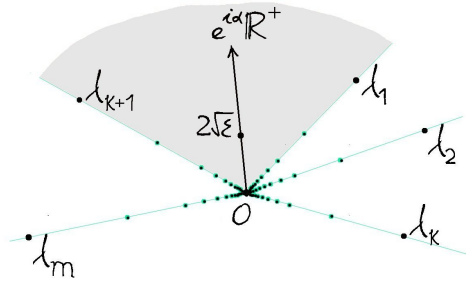

FIGURE 3.6. The resonant values of $\sqrt{\epsilon} = \frac{\lambda}{2n}$, $\lambda \in \text{Spec } M(\epsilon)$, $n \in \mathbb{N}^*$, accumulate along the rays $\lambda\mathbb{R}^+$, dividing the $\sqrt{\epsilon}$ -plane in sectors on which the local analytic solutions near $x = \sqrt{\epsilon} \neq 0$ converge as $\sqrt{\epsilon} \rightarrow 0$ to sectoral solutions.

3.2.3. Sectoral normalization of families of non-resonant linear differential systems.

An application of Theorem 3.2.4, interesting on its own, is the problem of existence of normalizing transformations for linear differential systems near an unfolded non-resonant irregular singularity of Poincaré rank 1. We will show that this problem can be reduced to a system (3.2.11) of $m = n(n-1)$ Riccati equations (where n is the dimension of the system), providing thus a simple proof of a sectoral normalization theorem by Lambert and Rousseau [LR].

Consider a parametric family of linear systems $\Delta(x, \epsilon)y = 0$ given by

$$\Delta(x, \epsilon) = (x^2 - \epsilon) \frac{d}{dx} - A(x, \epsilon), \quad (x, \epsilon) \in (\mathbb{C} \times \mathbb{C}, 0) \quad (3.2.14)$$

where $y(x, \epsilon) \in \mathbb{C}^n$, $A(x, \epsilon)$ is analytic, and assume that the eigenvalues $\lambda_i^{(0)}(0)$, $i = 1, \dots, n$, of the matrix $A(0, 0)$ are distinct. Let $\lambda_i(x, \epsilon) = \lambda_i^{(0)}(\epsilon) + x\lambda_i^{(1)}(\epsilon)$, $i = 1, \dots, n$, be the eigenvalues of $A(x, \epsilon)$ modulo $O(x^2 - \epsilon)$, and define

$$\widehat{\Delta}(x, \epsilon) = (x^2 - \epsilon) \frac{d}{dx} - \Lambda(x, \epsilon), \quad \Lambda(x, \epsilon) = \text{Diag}(\lambda_1(x, \epsilon), \dots, \lambda_n(x, \epsilon)), \quad (3.2.15)$$

the *formal normal form* for Δ . The problem we address, is to find a bounded invertible linear transformation $y = T(x, \sqrt{\epsilon})u$ between the two systems $\Delta y = 0$ and $\widehat{\Delta}u = 0$. Such T is a solution of the equation

$$(x^2 - \epsilon) \frac{dT}{dx} = AT - T\Lambda. \quad (3.2.16)$$

Note that if $V(x, \epsilon)$ is an analytic matrix of eigenvectors of $A(x, \epsilon)$ then the transformation $y = V(x, \epsilon)y_1$ brings the system $\Delta y = 0$ to $\Delta_1 y_1 = 0$, whose matrix is written as $A_1(x, \epsilon) = \Lambda(x, \epsilon) + (x^2 - \epsilon)R(x, \epsilon)$, with $R = -V^{-1} \frac{dV}{dx}$ (see [LR]). Hence we can suppose that system (3.2.14) is already in such form.

Theorem 3.2.7 ([LR], Theorem 4.21). *Let $\Delta(x, \epsilon)$ be a non-resonant system (3.2.14) with $A(x, \epsilon) = \Lambda(x, \epsilon) + (x^2 - \epsilon)R(x, \epsilon)$ for some analytic germ $R(x, \epsilon)$, and let $\widehat{\Delta}(x, \epsilon)$ be its formal normal form (3.2.15). Then there exists a family of ramified “spiraling” domains $Z(\sqrt{\epsilon})$, $\sqrt{\epsilon} \in S$, as in Theorem 3.2.4 (i), Figure 3.2, on which there exists a normalizing transformation $T(x, \sqrt{\epsilon})$, solution to the equation (3.2.16), which is uniformly continuous on*

$$Z = \{(x, \sqrt{\epsilon}) \mid x \in Z(\sqrt{\epsilon})\}$$

and analytic on its interior, and such that $T(\pm\sqrt{\epsilon}, \sqrt{\epsilon}) = I + O(\sqrt{\epsilon})$ is diagonal. This transformation T on Z is unique modulo right multiplication by an invertible diagonal matrix constant in x .

PROOF. Write $T(x, \sqrt{\epsilon}) = (I + U(x, \sqrt{\epsilon})) \cdot T_D(x, \sqrt{\epsilon})$, where $T_D(x, \sqrt{\epsilon})$ is the diagonal of T , and the matrix $U(x, \sqrt{\epsilon}) = O(x^2 - \epsilon)$ has only zeros on the diagonal. We search for $U(x, \sqrt{\epsilon})$, such that $y_D = (I + U(x, \sqrt{\epsilon}))^{-1}y$ satisfies

$$(x^2 - \epsilon) \frac{dy_D}{dx} - (\Lambda(x, \epsilon) + (x^2 - \epsilon)D(x, \sqrt{\epsilon}))y_D = 0,$$

for some diagonal matrix $D(x, \sqrt{\epsilon})$, and set

$$T_D(x, \sqrt{\epsilon}) = e^{\int_{\sqrt{\epsilon}}^x D(s, \sqrt{\epsilon}) ds}.$$

The matrix $U(x, \sqrt{\epsilon})$ is solution to

$$(x^2 - \epsilon) \frac{dU}{dx} = \Lambda U - U \Lambda + (x^2 - \epsilon) (R(I + U) - (I + U)D),$$

where one must set D to be equal to the diagonal of $R(I + U)$. Therefore, $U = (u_{ij})_{i,j=1}^n$ is solution to the system of $n(n-1)$ equations

$$(x^2 - \epsilon) \frac{du_{ij}}{dx} = (\lambda_i - \lambda_j)u_{ij} + (x^2 - \epsilon) \left(r_{ij} + \sum_{k \neq j} r_{ik}u_{kj} - u_{ij}r_{jj} - u_{ij} \sum_{k \neq j} r_{jk}u_{kj} \right), \quad i \neq j,$$

and one can apply Theorem 3.2.4. \square

3.3. PRELIMINARIES ON FOURIER–LAPLACE TRANSFORMATIONS

We will recall some basic elements of the classical theory of Fourier–Laplace transformations on a line in the complex plane. The book [Do] can serve as a good reference.

For an angle $\alpha \in \mathbb{R}$ and a locally integrable function $\phi : e^{i\alpha}\mathbb{R} \rightarrow \mathbb{C}$, one defines its *two-sided Laplace transform*

$$\mathcal{L}_\alpha[\phi](t) = \int_{-\infty e^{i\alpha}}^{+\infty e^{i\alpha}} \phi(\xi) e^{-t\xi} d\xi \quad (3.3.1)$$

whenever it exists. Later on, in Section 3.4, we will replace the variable t by the time variable $t(x, \epsilon)$ (3.4.1) of the vector field (3.2.6).

Definition 3.3.1. Let $A, B \in \mathbb{C}$ be such that $\operatorname{Re}(e^{i\alpha}A) < \operatorname{Re}(e^{i\alpha}B)$. Let us introduce the two following norms on locally integrable functions $\phi : e^{i\alpha}\mathbb{R} \rightarrow \mathbb{C}$:

$$\begin{aligned} |\phi|_{e^{i\alpha}\mathbb{R}}^{A,B} &= \sup_{\xi \in e^{i\alpha}\mathbb{R}} |\phi(\xi)| \cdot (|e^{-A\xi}| + |e^{-B\xi}|), \\ \|\phi\|_{e^{i\alpha}\mathbb{R}}^{A,B} &= \int_{-\infty e^{i\alpha}}^{+\infty e^{i\alpha}} |\phi(\xi)| \cdot (|e^{-A\xi}| + |e^{-B\xi}|) d\xi \cdot e^{-i\alpha}. \end{aligned}$$

Proposition 3.3.2. *If $\|\phi\|_{e^{i\alpha}\mathbb{R}}^{A,B} < +\infty$, then the Laplace transform $\mathcal{L}_\alpha[\phi](t)$ converges absolutely and is analytic for t in the closed strip*

$$\overline{T}_\alpha^{A,B} := \{t \in \mathbb{C} \mid \operatorname{Re}(e^{i\alpha}A) \leq \operatorname{Re}(e^{i\alpha}t) \leq \operatorname{Re}(e^{i\alpha}B)\}.$$

Moreover, $\mathcal{L}_\alpha[\phi](t)$ tends uniformly to 0 as $t \rightarrow \infty$ in $\overline{T}_\alpha^{A,B}$.

PROOF. The integral $\int_{-\infty e^{i\alpha}}^0 \phi(\xi) e^{-t\xi} d\xi$ converges absolutely in the closed half-plane $\operatorname{Re}(e^{i\alpha}t) \leq \operatorname{Re}(e^{i\alpha}B)$, while the integral $\int_0^{+\infty e^{i\alpha}} \phi(\xi) e^{-t\xi} d\xi$ converges absolutely in the closed half-plane $\operatorname{Re}(e^{i\alpha}t) \geq \operatorname{Re}(e^{i\alpha}A)$. For the second statement see [Do], Theorem 23.6. \square

Lemma 3.3.3. *If $A, B, D \in \mathbb{C}$ are such that $0 < \operatorname{Re}(e^{i\alpha}D) < \frac{1}{2}\operatorname{Re}(e^{i\alpha}(B - A))$, then for any function $\phi : e^{i\alpha}\mathbb{R} \rightarrow \mathbb{C}$,*

$$\|\phi\|_{e^{i\alpha}\mathbb{R}}^{A+D, B-D} \leq \frac{4}{\operatorname{Re}(e^{-i\alpha}D)} |\phi|_{e^{i\alpha}\mathbb{R}}^{A,B}.$$

PROOF.

$$\begin{aligned} & \int_{-\infty e^{i\alpha}}^0 |\phi(\xi)| (|e^{-(A+D)\xi}| + |e^{-(B-D)\xi}|) d\xi \cdot e^{-i\alpha} \\ & \leq \int_{-\infty}^0 |e^{e^{i\alpha}Ds}| ds \cdot \sup_{\xi \in e^{i\alpha}\mathbb{R}} |\phi(\xi)| (|e^{-A\xi-2D\xi}| + |e^{-B\xi}|) \\ & \leq \frac{1}{\operatorname{Re}(e^{i\alpha}D)} \cdot 2|\phi|_{e^{i\alpha}\mathbb{R}}^{A,B}, \end{aligned}$$

since $|e^{-A\xi-2D\xi}| \leq |e^{-B\xi}| \leq |e^{-A\xi}| + |e^{-B\xi}|$, for $\xi \in (-\infty e^{i\alpha}, 0]$. The same kind of estimate is obtained also for $\int_0^{+\infty e^{i\alpha}}$. \square

Corollary 3.3.4. *If $|\phi|_{e^{i\alpha}\mathbb{R}}^{A,B} < +\infty$, then the Laplace transform $\mathcal{L}_\alpha[\phi](t)$ converges absolutely and is analytic for t in the open strip*

$$T_\alpha^{A,B} := \{t \in \mathbb{C} \mid \operatorname{Re}(e^{i\alpha}A) < \operatorname{Re}(e^{i\alpha}t) < \operatorname{Re}(e^{i\alpha}B)\}.$$

Moreover, $\mathcal{L}_\alpha[\phi](t)$ tends to 0 as $t \rightarrow \infty$ uniformly in each $\overline{T}_\alpha^{A_1, B_1} \subseteq T_\alpha^{A,B}$.

Definition 3.3.5. The *Borel transformation* is defined for any function f analytic on some open strip $T_\alpha^{A,B}$, that vanishes at infinity uniformly in each closed substrip $\overline{T}_\alpha^{A_1,B_1} \subseteq T_\alpha^{A,B}$, by

$$\tilde{f}(\xi) = \mathcal{B}_\alpha[f](\xi) = \frac{1}{2\pi i} V.P. \int_{C-\infty ie^{-i\alpha}}^{C+\infty ie^{-i\alpha}} f(t) e^{t\xi} dt, \quad \text{for } \xi \in e^{i\alpha}\mathbb{R}, \quad (3.3.2)$$

where $V.P. \int_{C-\infty ie^{-i\alpha}}^{C+\infty ie^{-i\alpha}}$ stands for the ‘‘Cauchy principal value’’ $\lim_{N \rightarrow +\infty} \int_{C-ie^{-i\alpha}N}^{C+ie^{-i\alpha}N}$, and $C \in T_\alpha^{A,B}$.

The (two-sided) Laplace transformation (3.3.1) and the Borel transformation (3.3.2) of analytic functions are inverse one to the other when defined. We will only need the following particular statement.

Theorem 3.3.6.

1) Let $f \in \mathcal{O}(T_\alpha^{A,B})$ be absolutely integrable on each line $C+ie^{-i\alpha}\mathbb{R} \subseteq T_\alpha^{A,B}$ and vanishing at infinity uniformly in each closed sub-strip of $T_\alpha^{A,B}$. Then the Borel transform $\tilde{f}(\xi) = \mathcal{B}_\alpha[f](\xi)$ is absolutely convergent and continuous for all $\xi \in e^{i\alpha}\mathbb{R}$,

$$|\tilde{f}|_{e^{i\alpha}\mathbb{R}}^{A_1,B_1} \leq \frac{1}{2\pi} \sup_{C \in \overline{T}_\alpha^{A_1,B_1}} \left| \int_{C+ie^{-i\alpha}\mathbb{R}} |f(t)| dt \right| \quad \text{for } \overline{T}_\alpha^{A_1,B_1} \subseteq T_\alpha^{A,B},$$

and $f(t) = \mathcal{L}_\alpha[\tilde{f}](t)$ for all $t \in T_\alpha^{A,B}$.

2) Let f be as in 1) with $B = B_1 = +\infty e^{-i\alpha}$, the strips being replaced by half-planes. Then the Borel transform $\tilde{f}(\xi) = \mathcal{B}_\alpha[f](\xi)$ is absolutely convergent and continuous on $e^{i\alpha}\mathbb{R}$, and $\tilde{f}(\xi) = 0$ for $\xi \in (-\infty e^{i\alpha}, 0)$,

$$|\tilde{f}|_{e^{i\alpha}\mathbb{R}}^{A_1,+\infty e^{-i\alpha}} = \sup_{\xi \in (0,+\infty e^{i\alpha})} |\tilde{f}(\xi) e^{-A_1 \xi}| \leq \frac{1}{2\pi} \sup_{\text{Re}(e^{i\alpha}C) \geq \text{Re}(e^{i\alpha}A_1)} \left| \int_{C-\infty ie^{-i\alpha}}^{C+\infty ie^{-i\alpha}} |f(t)| dt \right|,$$

and

$$f(t) = \mathcal{L}_\alpha[\tilde{f}](t) = \int_0^{+\infty e^{i\alpha}} \tilde{f}(\xi) e^{-t\xi} d\xi$$

is the one-sided Laplace transform of \tilde{f} in the direction α .

PROOF. See [Do], Theorems 28.1 and 28.2. □

Under the assumptions of Theorem 3.3.6, the Borel transformation converts derivative to multiplication by $-\xi$:

$$\mathcal{B}_\alpha\left[\frac{df}{dt}\right](\xi) = -\xi \cdot \mathcal{B}_\alpha[f](\xi),$$

which can be seen by integration by parts. It also converts the product to the convolution:

$$\mathcal{B}_\alpha[f_1 \cdot f_2](\xi) = [\tilde{f}_1 * \tilde{f}_2]_\alpha(\xi),$$

defined by

$$[\phi * \psi]_\alpha(\xi) = [\psi * \phi]_\alpha(\xi) := \int_{-\infty e^{i\alpha}}^{+\infty e^{i\alpha}} \phi(s) \psi(\xi - s) ds. \quad (3.3.3)$$

Indeed, we have $\mathcal{L}_\alpha[\tilde{f}_1 * \tilde{f}_2](t) = \mathcal{L}_\alpha[\tilde{f}_1](t) \cdot \mathcal{L}_\alpha[\tilde{f}_2](t) = f_1(t) \cdot f_2(t)$ using Fubini theorem and Theorem 3.3.6, and the assertion is obtained by the inversion theorem of the Laplace transform: $\mathcal{B}_\alpha[\mathcal{L}_\alpha[\phi]](\xi) = \frac{1}{2} \lim_{\nu \rightarrow 0^+} \phi(\xi + e^{i\alpha}\nu) + \phi(\xi - e^{i\alpha}\nu)$ (cf. [Do], Theorem 24.3), using the continuity of $[\tilde{f}_1 * \tilde{f}_2]_\alpha(\xi)$.

Lemma 3.3.7 (Young's inequality).

$$\begin{aligned} |\phi * \psi|_{e^{i\alpha}\mathbb{R}}^{A,B} &\leq |\phi|_{e^{i\alpha}\mathbb{R}}^{A,B} \cdot \|\psi\|_{e^{i\alpha}\mathbb{R}}^{A,B} \quad (\text{and } \leq \|\phi\|_{e^{i\alpha}\mathbb{R}}^{A,B} \cdot |\psi|_{e^{i\alpha}\mathbb{R}}^{A,B}), \\ \|\phi * \psi\|_{e^{i\alpha}\mathbb{R}}^{A,B} &\leq \|\phi\|_{e^{i\alpha}\mathbb{R}}^{A,B} \cdot \|\psi\|_{e^{i\alpha}\mathbb{R}}^{A,B}. \end{aligned}$$

PROOF. Observe that

$$(|e^{-A\xi}| + |e^{-B\xi}|) \leq (|e^{-As}| + |e^{-Bs}|) \cdot (|e^{-A(\xi-s)}| + |e^{-B(\xi-s)}|), \quad (3.3.4)$$

the rest follows easily. \square

3.3.1. Convolution of analytic functions on open strips.

In the subsequent text, rather than dealing with functions on a single line $e^{i\alpha}\mathbb{R}$, one will work with functions which are analytic on some open strips in the ξ -plane (also called the *Borel plane*), or on more general regions obtained as a connected union of open strips of varying directions α .

If Ω is a non-empty open strip in direction α , then for two constants $A, B \in \mathbb{C}$, with $\operatorname{Re}(e^{i\alpha}A) < \operatorname{Re}(e^{i\alpha}B)$, define the norm of analytic functions $\phi \in \mathcal{O}(\Omega)$,

$$\begin{aligned} |\phi|_\Omega^{A,B} &= \sup_{c+e^{i\alpha}\mathbb{R} \subseteq \Omega} |\phi|_{c+e^{i\alpha}\mathbb{R}}^{A,B}, \\ \|\phi\|_\Omega^{A,B} &= \sup_{c+e^{i\alpha}\mathbb{R} \subseteq \Omega} \|\phi\|_{c+e^{i\alpha}\mathbb{R}}^{A,B}. \end{aligned}$$

Similarly for more general domains. For any two strips Ω_j , $j = 1, 2$, of the same direction α , and two analytic functions $\phi_j \in \mathcal{O}(\Omega_j)$ of bounded $\|\cdot\|_\Omega^{A,B}$ -norm, their convolution

$$(\phi_1 * \phi_2)(\xi) = \int_{c_1 - \infty e^{i\alpha}}^{c_1 + \infty e^{i\alpha}} \phi_1(s) \phi_2(\xi - s) ds, \quad \xi \in c_1 + c_2 + e^{i\alpha}\mathbb{R}, \quad c_j \in \Omega_j$$

is well defined and analytic on the strip $\Omega_1 + \Omega_2$. The Young's inequalities of Lemma 3.3.7 are easily generalized as

$$|\phi_1 * \phi_2|_{\Omega_1 + \Omega_2}^{A,B} \leq \min \{ |\phi_1|_{\Omega_1}^{A,B} \cdot \|\phi_2\|_{\Omega_2}^{A,B}, \|\phi_1\|_{\Omega_1}^{A,B} \cdot |\phi_2|_{\Omega_2}^{A,B} \} \quad (3.3.5)$$

$$\|\phi_1 * \phi_2\|_{\Omega_1 + \Omega_2}^{A,B} \leq \|\phi_1\|_{\Omega_1}^{A,B} \cdot \|\phi_2\|_{\Omega_2}^{A,B}. \quad (3.3.6)$$

3.3.2. Dirac distributions in the Borel plane.

It is convenient to introduce for each $a \in \mathbb{C}$ the Dirac mass distribution $\delta_a(\xi)$, acting on the ξ -plane as shift operators $\xi \mapsto \xi - a$: If $\phi(\xi)$ is an analytic function on some strip Ω in a direction α one defines

$$[\delta_a * \phi](\xi) := \phi(\xi - a),$$

its translation to the strip $\Omega - a$. With this definition, the operator δ_0 plays the role of the unity of convolution. One can represent each δ_a as a “boundary value” of the function $\frac{1}{2\pi i(\xi - a)}$ (cf. [Bre]): Let

$$\delta_a^\downarrow(\xi) := \frac{1}{2\pi i(\xi - a)} \upharpoonright \mathbb{C} \setminus [a, a + \infty i e^{i\alpha}], \quad \delta_a^\uparrow(\xi) := \frac{1}{2\pi i(\xi - a)} \upharpoonright \mathbb{C} \setminus [a, a - \infty i e^{i\alpha}],$$

be its restrictions to the two cut regions (see Figure 3.7). One then writes

$$\delta_a(\xi) = \delta_a^\downarrow(\xi) - \delta_a^\uparrow(\xi),$$

and defines the convolution and the Laplace transform involving δ_a by integrating each term δ_a^\downarrow (resp. δ_a^\uparrow) along deformed paths γ_α^\downarrow (resp. γ_α^\uparrow) of direction α in their respective domains as in Figure 3.7,

$$\begin{aligned} [\delta_a * \phi](\xi) &= V.P. \int_{\gamma_\alpha^\downarrow - \gamma_\alpha^\uparrow} \frac{1}{2\pi i(s - a)} \phi(\xi - s) ds = \phi(\xi - a), \\ \mathcal{L}_\alpha[\delta_a](t) &= V.P. \int_{\gamma_\alpha^\downarrow - \gamma_\alpha^\uparrow} \frac{1}{2\pi i(\xi - a)} e^{-t\xi} d\xi = e^{-at}. \end{aligned}$$

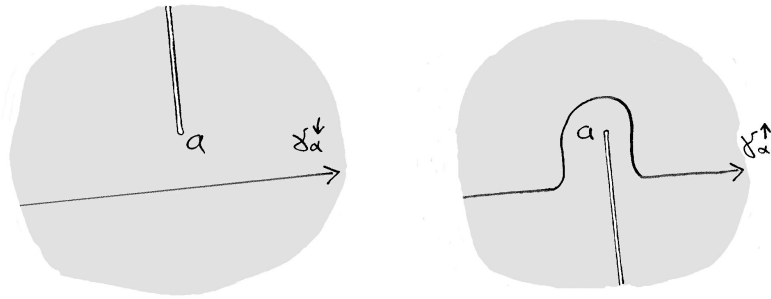

FIGURE 3.7. The domains of definition of δ_a^\downarrow (resp. δ_a^\uparrow) together with the deformed integration paths γ_α^\downarrow (resp. γ_α^\uparrow).

3.4. THE BOREL AND LAPLACE TRANSFORMATIONS ASSOCIATED TO THE VECTOR FIELD $(x^2 - \epsilon) \frac{\partial}{\partial x}$

In this section we define the unfolded Borel and Laplace transformations $\mathcal{B}_\alpha, \mathcal{L}_\alpha$ (3.2.7) and summarize their basic properties. We need to specify:

- the time function $t(x, \epsilon)$ of the kernel,
- the paths of integration,
- the domains in x -space and ξ -space where the transformations live,
- sufficient conditions on functions for which the transformations exist.

We provide these depending analytically on a root parameter $\sqrt{\epsilon} \in \mathbb{C}$. Here $\sqrt{\epsilon}$ is to be interpreted simply as a symbol for a new parameter (a coordinate on the “ $\sqrt{\epsilon}$ -plane”), that naturally projects on the original parameter $\epsilon = (\sqrt{\epsilon})^2$.

Let

$$t(x, \epsilon) = - \int \frac{dx}{x^2 - \epsilon} := \begin{cases} -\frac{1}{2\sqrt{\epsilon}} \log \frac{x - \sqrt{\epsilon}}{x + \sqrt{\epsilon}}, & \text{if } \epsilon \neq 0, \\ \frac{1}{x}, & \text{if } \epsilon = 0, \end{cases} \quad (3.4.1)$$

with $t(\infty, \epsilon) = 0$, be the complex time of the vector field $-(x^2 - \epsilon) \frac{\partial}{\partial x}$; well defined for $x \in \mathbb{CP}^1 \setminus [-\sqrt{\epsilon}, \sqrt{\epsilon}]$. And let $\check{X}(\sqrt{\epsilon})$ denote the Riemann surface of the analytic continuation of $t(\cdot, \epsilon)$. Let us remark that the limit surface $\lim_{\sqrt{\epsilon} \rightarrow 0} \check{X}(\sqrt{\epsilon})$ is composed of \mathbb{Z} -many complex planes identified at the origin, but the surface $\check{X}(0)$ is just the x -plane in the middle.

Definition 3.4.1. For $0 \leq \Lambda < \frac{\pi}{2\sqrt{|\epsilon|}}$, denote

$$X(\Lambda, \sqrt{\epsilon}) := \{x \in \mathbb{C} \mid |t(x, \epsilon) - k \frac{\pi i}{\sqrt{\epsilon}}| > \Lambda, k \in \mathbb{Z}\}$$

an open neighborhood of the origin in the x -plane (of radius $\sim \frac{1}{\Lambda}$ when ϵ is small) containing the roots $\pm\sqrt{\epsilon}$.

If α is a direction, assuming that Λ satisfies $0 \leq 2\Lambda < -\text{Re}(\frac{e^{i\alpha}\pi i}{\sqrt{\epsilon}})$, denote

$$\check{X}_\alpha^+(\Lambda, \sqrt{\epsilon}) := \{x \in \check{X}(\sqrt{\epsilon}) \mid \Lambda < \text{Re}(e^{i\alpha}t(x, \epsilon)) < -\text{Re}(\frac{e^{i\alpha}\pi i}{\sqrt{\epsilon}}) - \Lambda\},$$

$$\check{X}_\alpha^-(\Lambda, \sqrt{\epsilon}) := \{x \in \check{X}(\sqrt{\epsilon}) \mid -\Lambda > \text{Re}(e^{i\alpha}t(x, \epsilon)) > \text{Re}(\frac{e^{i\alpha}\pi i}{\sqrt{\epsilon}}) + \Lambda\},$$

open domains of the ramified surface $\check{X}(\sqrt{\epsilon})$, corresponding to slanted strips of direction $-\alpha + \frac{\pi}{2}$ in the t -coordinate passing between two discs of radius Λ centered at 0 and $\mp \frac{\pi i}{\sqrt{\epsilon}}$ (see Figures 3.8 and 3.9). Their projection to the x -plane is contained inside the neighborhood $X(\Lambda, \sqrt{\epsilon})$. Let us remark that the radial limits $\lim_{\nu \rightarrow 0} \check{X}_\alpha^\pm(\Lambda, \nu\sqrt{\epsilon})$ split each into two opposed discs of radius $\frac{1}{2\Lambda}$ tangent at the origin, of which only one lies inside the surface $\check{X}(0)$ (i.e. the x -plane): $\check{X}_\alpha^+(\Lambda, 0)$ is a disc centered at $e^{i\alpha} \frac{1}{2\Lambda}$, and $\check{X}_\alpha^-(\Lambda, 0)$ is a disc centered at $-e^{i\alpha} \frac{1}{2\Lambda}$ (Figure 3.9 (b)).

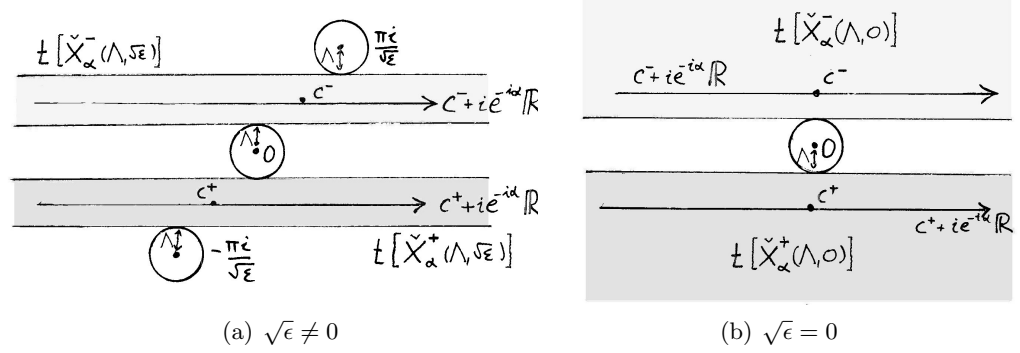

FIGURE 3.8. The domains $\check{X}_\alpha^\pm(\Lambda, \sqrt{\epsilon})$ in the time coordinate t with the integration paths of the Borel transformation for $\alpha = \frac{\pi}{2}$.

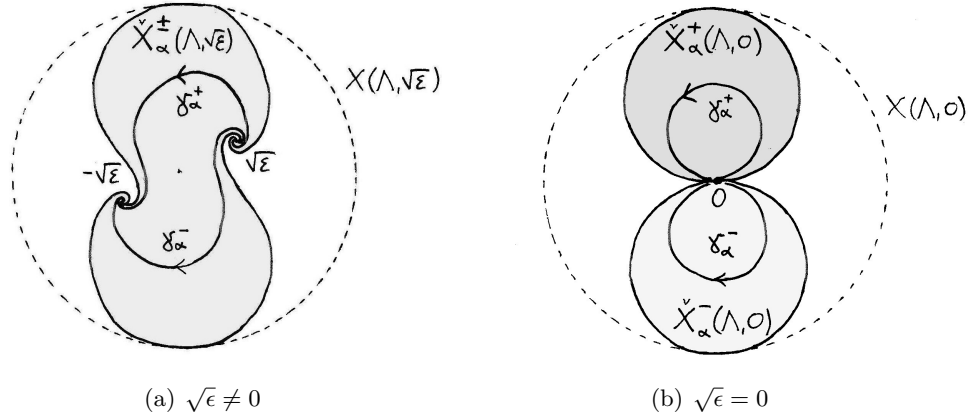

FIGURE 3.9. The domains $\check{X}_\alpha^\pm(\Lambda, \sqrt{\epsilon})$ projected to the x -plane for $\alpha = \frac{\pi}{2}$. The integration paths γ_α^\pm are projections of the paths $c^\pm - ie^{-i\alpha}\mathbb{R}$ in the t -coordinate (which have opposite direction than those in Figure 3.8).

In order to apply the Borel transformation (3.3.2) in a direction α to a function f analytic on the neighborhood $X(\Lambda, \sqrt{\epsilon})$, one may choose to lift f either to $\check{X}_\alpha^+(\Lambda, \sqrt{\epsilon})$ or to $\check{X}_\alpha^-(\Lambda, \sqrt{\epsilon})$ giving rise to two different transforms $\mathcal{B}_\alpha^+[f]$ and $\mathcal{B}_\alpha^-[f]$:

Definition 3.4.2. Assume that $\check{X}_\alpha^\pm(\Lambda, \sqrt{\epsilon}) \neq \emptyset$, $\alpha \in (\arg \sqrt{\epsilon}, \arg \sqrt{\epsilon} + \pi)$, and let $f \in \mathcal{O}(\check{X}_\alpha^\pm(\Lambda, \sqrt{\epsilon}))$ vanish at both points $\sqrt{\epsilon}, -\sqrt{\epsilon}$. The *unfolded Borel transforms* $\mathcal{B}_\alpha^\pm[f]$ are defined as:

$$\mathcal{B}_\alpha^\pm[f](\xi, \sqrt{\epsilon}) = \frac{1}{2\pi i} \int_{c^\pm - \infty i e^{-i\alpha}}^{c^\pm + \infty i e^{-i\alpha}} f(x(t, \epsilon)) e^{t\xi} dt, \quad c^\pm \in t[\check{X}_\alpha^\pm(\Lambda, \sqrt{\epsilon}), \epsilon].$$

For $\sqrt{\epsilon} \neq 0$: If $x \in \check{X}_\alpha^\pm(\Lambda, \sqrt{\epsilon})$ respectively, then $t(x, \epsilon) = -\frac{1}{2\sqrt{\epsilon}} \left(\log \frac{\sqrt{\epsilon}-x}{\sqrt{\epsilon}+x} \pm \pi i \right)$,

$$\mathcal{B}_\alpha^\pm[f](\xi, \sqrt{\epsilon}) = e^{\mp \frac{\xi \pi i}{2\sqrt{\epsilon}}} \cdot \frac{1}{2\pi i} \int_{\gamma_\alpha^\pm} \frac{f(x)}{x^2 - \epsilon} \left(\frac{\sqrt{\epsilon}-x}{\sqrt{\epsilon}+x} \right)^{-\frac{\xi}{2\sqrt{\epsilon}}} dx, \quad (3.4.2)$$

where the integration path γ_α^\pm (see Figure 3.9) follows a real time trajectory of the vector field $ie^{-i\alpha}(x^2-\epsilon)\frac{\partial}{\partial x}$ inside $\check{X}_\alpha^\pm(\Lambda, \sqrt{\epsilon})$. Hence

$$\mathcal{B}_\alpha^-[f](\xi, \sqrt{\epsilon}) = e^{\frac{\xi\pi i}{\sqrt{\epsilon}}} \cdot \mathcal{B}_\alpha^+[f](\xi, \sqrt{\epsilon}) \quad (3.4.3)$$

$$= -\mathcal{B}_{\alpha+\pi}^+[f](\xi, e^{\pi i}\sqrt{\epsilon}), \quad (3.4.4)$$

as $\check{X}_\alpha^-(\Lambda, \sqrt{\epsilon}) = \check{X}_{\alpha+\pi}^+(\Lambda, e^{\pi i}\sqrt{\epsilon})$.

For $\sqrt{\epsilon} = 0$:

$$\mathcal{B}_\alpha^\pm[f](\xi, 0) = \frac{1}{2\pi i} \int_{\gamma_\alpha^\pm} \frac{f(x)}{x^2} e^{\frac{\xi}{x}} dx, \quad (3.4.5)$$

where γ_α^\pm is a real time trajectory of the vector field $ie^{-i\alpha}x^2\frac{\partial}{\partial x}$ inside $\check{X}_\alpha^\pm(\Lambda, 0)$. It is the radial limit of the precedent case as $\sqrt{\epsilon} \rightarrow 0$,

$$\mathcal{B}_\alpha^\pm[f](\xi, 0) = \lim_{\nu \rightarrow 0^+} \mathcal{B}_\alpha^\pm[f](\xi, \nu\sqrt{\epsilon}).$$

The transformation $\mathcal{B}_\alpha^+[f](\xi, 0)$ is the standard analytic Borel transform (3.2.4) in direction α , and

$$\mathcal{B}_\alpha^-[f](\xi, 0) = -\mathcal{B}_{\alpha+\pi}^+[f](\xi, 0). \quad (3.4.6)$$

If $f = f(x, \epsilon)$ depends analytically on ϵ , we define $\mathcal{B}_\alpha^\pm[f](\xi, \sqrt{\epsilon}) := \mathcal{B}_\alpha^\pm[f(\cdot, \epsilon)](\xi, \sqrt{\epsilon})$.

The following proposition summarizes some basic proprieties of these unfolded Borel transformations.

Proposition 3.4.3. *Let α be a direction, and suppose that $\arg \sqrt{\epsilon} \in (\alpha - \pi, \alpha)$ if $\epsilon \neq 0$.*

1) *If $\sqrt{\epsilon} \neq 0$, let a function $f \in \mathcal{O}(\check{X}_\alpha^\pm(\Lambda, \sqrt{\epsilon}))$, be uniformly $O(|x-\sqrt{\epsilon}|^a|x+\sqrt{\epsilon}|^b)$ at the points $\pm\sqrt{\epsilon}$, for some $a, b \in \mathbb{R}$ with $a+b > 0$. Then the transforms $\mathcal{B}_\alpha^\pm[f](\xi, \sqrt{\epsilon})$ converge absolutely for ξ in the strip*

$$\Omega_\alpha = \{-\text{Im}(e^{-i\alpha}2b\sqrt{\epsilon}) > \text{Im}(e^{-i\alpha}\xi) > \text{Im}(e^{-i\alpha}2a\sqrt{\epsilon})\}, \quad (3.4.7)$$

see Figure 3.10, and are analytic extensions of each other for varying α . Moreover for any $\Lambda < \Lambda_1 < -\text{Re}(\frac{e^{i\alpha}\pi i}{2\sqrt{\epsilon}})$ and $A = e^{-i\alpha}\Lambda_1$, $B = -\frac{e^{i\alpha}\pi i}{\sqrt{\epsilon}} - e^{-i\alpha}\Lambda_1$, they are of bounded norm $|\mathcal{B}_\alpha^\pm[f]|_{c+e^{i\alpha}\mathbb{R}}^{A,B}$ on any line $c + e^{i\alpha}\mathbb{R} \subseteq \Omega_\alpha$.

2) *If $\sqrt{\epsilon} \neq 0$ and $a+b > 0$, then for $\xi \in \Omega_\alpha$ (defined in (3.4.7))*

$$\mathcal{B}_\alpha^+[(x-\sqrt{\epsilon})^a(x+\sqrt{\epsilon})^b](\xi, \sqrt{\epsilon}) = e^{-\frac{\xi\pi i}{2\sqrt{\epsilon}}+a\pi i} \cdot (2\sqrt{\epsilon})^{a+b-1} \cdot \frac{1}{2\pi i} B(a - \frac{\xi}{2\sqrt{\epsilon}}, b + \frac{\xi}{2\sqrt{\epsilon}}),$$

where B is the Beta function.

3) *In particular, for a positive integer n , and ξ in the strip in between 0 and $2n\sqrt{\epsilon}$,*

$$\mathcal{B}_\alpha^\pm[(x-\sqrt{\epsilon})^n](\xi, \sqrt{\epsilon}) = \chi_\alpha^\pm(\xi, \sqrt{\epsilon}) \cdot (\frac{\xi}{(n-1)} - 2\sqrt{\epsilon}) \cdot (\frac{\xi}{(n-2)} - 2\sqrt{\epsilon}) \cdot \dots \cdot (\frac{\xi}{1} - 2\sqrt{\epsilon}),$$

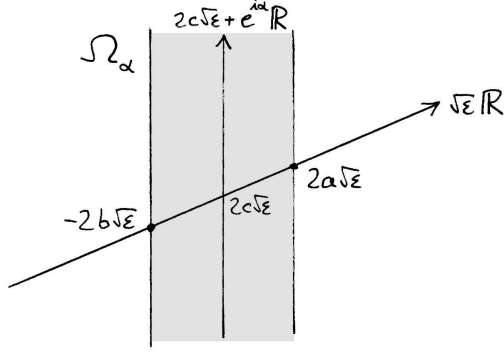
FIGURE 3.10. The strip Ω_α in the ξ -plane.

where for $\sqrt{\epsilon} \neq 0$ and $\alpha \in (\arg \sqrt{\epsilon}, \arg \sqrt{\epsilon} + \pi)$

$$\chi_\alpha^+(\xi, \sqrt{\epsilon}) := \frac{1}{1 - e^{-\frac{\xi\pi i}{\sqrt{\epsilon}}}}, \quad \chi_\alpha^-(\xi, \sqrt{\epsilon}) := \frac{-1}{1 - e^{-\frac{\xi\pi i}{\sqrt{\epsilon}}}}, \quad (3.4.8)$$

and for $\sqrt{\epsilon} = 0$

$$\chi_\alpha^+(\xi, 0) := \begin{cases} 1, & \text{if } \xi \in (0, +\infty e^{i\alpha}), \\ \frac{1}{2}, & \text{if } \xi = 0, \\ 0, & \text{if } \xi \in (-\infty e^{i\alpha}, 0), \end{cases} \quad \chi_\alpha^-(\xi, 0) := \chi_\alpha^+(\xi, 0) - 1.$$

Let us remark that $\chi_\alpha^\pm(\xi, \nu\sqrt{\epsilon}) \xrightarrow{\nu \rightarrow 0^+} \chi_\alpha^\pm(\xi, 0)$ for $\xi \in e^{i\alpha}\mathbb{R} \setminus \{0\}$.

4) If $f(x)$ is analytic on an open disc of radius $r > 2\sqrt{|\epsilon|}$ centered at $x_0 = -\sqrt{\epsilon}$ (or $x_0 = \sqrt{\epsilon}$) and $f(x_0) = 0$, then

$$\mathcal{B}_\alpha^\pm[f](\xi, \sqrt{\epsilon}) = \chi_\alpha^\pm(\xi, \sqrt{\epsilon}) \cdot \phi(\xi)$$

where ϕ is an entire function with at most exponential growth at infinity $\leq e^{\frac{|\xi|}{R-2\sqrt{|\epsilon|}}}$. $O(\sqrt{|\xi|})$ for any $2\sqrt{|\epsilon|} < R < r$ (where the big O is uniform for $(\xi, \sqrt{\epsilon}) \rightarrow (\infty, 0)$).

5) For $\sqrt{\epsilon} \neq 0$, $c \in \mathbb{C}$, the Borel Transform $\mathcal{B}_\alpha^\pm \left[\left(\frac{x-\sqrt{\epsilon}}{x+\sqrt{\epsilon}} \right)^c \right](\xi, \sqrt{\epsilon}) = \delta_{2c\sqrt{\epsilon}}(\xi)$ is the Dirac mass at $2c\sqrt{\epsilon}$, acting as translation operator on the Borel plane by $\xi \mapsto \xi - 2c\sqrt{\epsilon}$:

$$\mathcal{B}_\alpha^\pm \left[\left(\frac{x-\sqrt{\epsilon}}{x+\sqrt{\epsilon}} \right)^c \cdot f \right](\xi, \sqrt{\epsilon}) = \mathcal{B}_\alpha^\pm[f](\xi - 2c\sqrt{\epsilon}, \sqrt{\epsilon}).$$

Remark 3.4.4. Although in 1) and 2) of Proposition 3.4.3 the function $f = O((x-\sqrt{\epsilon})^a(x+\sqrt{\epsilon})^b)$, $a+b > 0$, might not vanish at both points $\pm\sqrt{\epsilon}$ as demanded in Definition 3.4.2, one can write

$$(x-\sqrt{\epsilon})^a(x+\sqrt{\epsilon})^b = \left(\frac{x-\sqrt{\epsilon}}{x+\sqrt{\epsilon}} \right)^c (x-\sqrt{\epsilon})^{a-c}(x+\sqrt{\epsilon})^{b+c}, \quad \text{for any } -b < c < a,$$

hence, using 5) of Proposition 3.4.3, the Borel transform $\mathcal{B}_\alpha^\pm[f]$ is well defined as the translation by $2c\sqrt{\epsilon}$ of the Borel transform of the function $f \cdot \left(\frac{x-\sqrt{\epsilon}}{x+\sqrt{\epsilon}}\right)^{-c}$, this time vanishing at both points:

$$\mathcal{B}_\alpha^\pm[f](\xi, \sqrt{\epsilon}) = \mathcal{B}_\alpha^\pm\left[f \cdot \left(\frac{x-\sqrt{\epsilon}}{x+\sqrt{\epsilon}}\right)^{-c}\right](\xi - 2c\sqrt{\epsilon}, \sqrt{\epsilon}).$$

PROOF OF PROPOSITION 3.4.3. 1) For $\sqrt{\epsilon} \neq 0$, one can express

$$x - \sqrt{\epsilon} = 2\sqrt{\epsilon} \frac{e^{-2\sqrt{\epsilon}t}}{1 - e^{-2\sqrt{\epsilon}t}}, \quad x + \sqrt{\epsilon} = 2\sqrt{\epsilon} \frac{1}{1 - e^{-2\sqrt{\epsilon}t}}.$$

If ξ is in the strip Ω_α , $\xi \in 2c\sqrt{\epsilon} + e^{i\alpha}\mathbb{R}$ for some $c \in (-b, a)$, one writes

$$\begin{aligned} \mathcal{B}_\alpha^\pm[(x - \sqrt{\epsilon})^a(x + \sqrt{\epsilon})^b](\xi, \sqrt{\epsilon}) &= \frac{1}{2\pi i} \int_{C^\pm + e^{-i\alpha}\mathbb{R}} (x - \sqrt{\epsilon})^{a-c}(x + \sqrt{\epsilon})^{b+c} e^{(\xi - 2c\sqrt{\epsilon})t} dt \\ &= (2\sqrt{\epsilon})^{a+b} \frac{1}{2\pi i} \int_{C^\pm + e^{-i\alpha}\mathbb{R}} \frac{(e^{-2\sqrt{\epsilon}t})^{a-c}}{(1 - e^{-2\sqrt{\epsilon}t})^{a+b}} e^{(\xi - 2c\sqrt{\epsilon})t} dt. \end{aligned}$$

The term $e^{(\xi - 2c\sqrt{\epsilon})t}$ stays bounded along the integration path, while the term $\frac{e^{-2\sqrt{\epsilon}t(a-c)}}{(1 - e^{-2\sqrt{\epsilon}t})^{a+b}}$ decreases exponentially fast as $t - C^\pm \rightarrow +\infty i e^{-i\alpha}$ and $t - C^\pm \rightarrow -\infty i e^{-i\alpha}$, if $\alpha \notin \arg \sqrt{\epsilon} + \pi\mathbb{Z}$.

2) From (3.4.2)

$$\begin{aligned} \mathcal{B}_\alpha^+[(x - \sqrt{\epsilon})^a(x + \sqrt{\epsilon})^b](\xi, \sqrt{\epsilon}) &= -e^{-\frac{\xi\pi i}{2\sqrt{\epsilon}} + a\pi i} \frac{1}{2\pi i} \int_{\gamma_\alpha^+} (\sqrt{\epsilon} - x)^{a-1-\frac{\xi}{2\sqrt{\epsilon}}} (\sqrt{\epsilon} + x)^{b-1+\frac{\xi}{2\sqrt{\epsilon}}} dx \\ &= e^{-\frac{\xi\pi i}{2\sqrt{\epsilon}} + a\pi i} \cdot (2\sqrt{\epsilon})^{a+b-1} \cdot \frac{1}{2\pi i} \int_0^1 (1-s)^{a-1-\frac{\xi}{2\sqrt{\epsilon}}} s^{b-1+\frac{\xi}{2\sqrt{\epsilon}}} ds, \end{aligned}$$

substituting $s = \frac{\sqrt{\epsilon}+x}{2\sqrt{\epsilon}}$. For $\alpha = \arg \sqrt{\epsilon} + \frac{\pi}{2}$, the integration path γ_α^+ (= a real trajectory of the vector field $e^{-i \arg \sqrt{\epsilon}}(x^2 - \epsilon) \frac{\partial}{\partial x}$) can be chosen as the straight oriented segment $(\sqrt{\epsilon}, -\sqrt{\epsilon})$. The result follows.

3) From 2) using standard formulas.

4) For $x_0 = -\sqrt{\epsilon}$, one can write $f(x)$ as a convergent series $f(x) = \sum_{n=1}^{+\infty} a_n (x + \sqrt{\epsilon})^n$ with $|a_n| \leq CK^n$ for some $C > 0$ and $\frac{1}{r} < K < \frac{1}{R}$. Hence

$$(1 - e^{\frac{\xi\pi i}{\sqrt{\epsilon}}}) \cdot \mathcal{B}^+[f](\xi, \sqrt{\epsilon}) = \sum_{n=1}^{+\infty} a_n \left(\frac{\xi}{n-1} - 2\sqrt{\epsilon}\right) \cdots \left(\frac{\xi}{1} - 2\sqrt{\epsilon}\right) =: \sum_{n=1}^{+\infty} b_n(\xi, \sqrt{\epsilon}),$$

where the series on the right is absolutely convergent for any $\xi \in \mathbb{C}$. Indeed, let $N = N(\xi, \sqrt{\epsilon})$ be the positive integer such that

$$\frac{|\xi|}{N+1} \leq R - 2\sqrt{|\epsilon|} < \frac{|\xi|}{N}, \quad (3.4.9)$$

then

- for $n \geq N + 1$: $K \cdot \left(\frac{|\xi|}{n} + 2\sqrt{|\epsilon|}\right) \leq RK$,

- for $n \leq N$: $2\sqrt{|\epsilon|} < \frac{2\sqrt{|\epsilon|}}{R-2\sqrt{|\epsilon|}} \frac{|\xi|}{n}$ and hence $K \cdot \left(\frac{|\xi|}{n} + 2\sqrt{|\epsilon|}\right) \leq \frac{K|\xi|}{n} \left(1 + \frac{2\sqrt{|\epsilon|}}{R-2\sqrt{|\epsilon|}}\right) \leq \frac{1}{n} \cdot \frac{|\xi|}{R-2\sqrt{|\epsilon|}}$.

$$\begin{aligned}
\sum_{n=1}^{+\infty} |b_n(\xi, \sqrt{\epsilon})| &= \sum_{n=0}^{N-1} |b_{n+1}(\xi, \sqrt{\epsilon})| + \sum_{n=N}^{+\infty} |b_{n+1}(\xi, \sqrt{\epsilon})| \\
&\leq \sum_{n=0}^{N-1} CK \frac{1}{n!} \left(\frac{|\xi|}{R-2\sqrt{|\epsilon|}}\right)^n + CK \frac{1}{N!} \left(\frac{|\xi|}{R-2\sqrt{|\epsilon|}}\right)^N \cdot \sum_{n=N}^{+\infty} (RK)^{n-N} \\
&\leq CK e^{\frac{|\xi|}{R-2\sqrt{|\epsilon|}}} + CK \cdot \Gamma\left(\frac{|\xi|}{R-2\sqrt{|\epsilon|}}\right)^{-1} \left(\frac{|\xi|}{R-2\sqrt{|\epsilon|}}\right)^{\frac{|\xi|}{R-2\sqrt{|\epsilon|}}} \cdot \frac{1}{1-RK} \\
&= e^{\frac{|\xi|}{R-2\sqrt{|\epsilon|}}} \cdot \left(CK + \frac{CK}{1-RK} \sqrt{\frac{|\xi|}{2\pi(R-2\sqrt{|\epsilon|})}} + O\left(\sqrt{\frac{R-2\sqrt{|\epsilon|}}{|\xi|}}\right)\right),
\end{aligned}$$

using (3.4.9) and the Stirling formula: $\Gamma(z)^{-1} = \left(\frac{e}{z}\right)^z \cdot \left(\sqrt{\frac{z}{2\pi}} + O\left(\frac{1}{\sqrt{z}}\right)\right)$, $z \rightarrow +\infty$.

5) From the definition. \square

There is also a converse statement to point 1) of Proposition 3.4.3.

Proposition 3.4.5. *Let $\epsilon \neq 0$ and $\alpha \in (\arg \sqrt{\epsilon}, \arg \sqrt{\epsilon} + \pi)$. If $\phi(\xi)$ is an analytic function in a strip Ω_α (3.4.7), with $a + b > 0$, such that it has a finite norm $|\phi|_{2c\sqrt{\epsilon} + e^{i\alpha}\mathbb{R}}^{A,B}$ on each line $2c\sqrt{\epsilon} + e^{i\alpha}\mathbb{R} \subseteq \Omega_\alpha$, for some $0 \leq \Lambda < -\operatorname{Re}\left(\frac{e^{i\alpha}\pi i}{2\sqrt{\epsilon}}\right)$ and $A = e^{-i\alpha}\Lambda$, $B = -\frac{e^{i\alpha}\pi i}{\sqrt{\epsilon}} - e^{-i\alpha}\Lambda$, then the unfolded Laplace transform of ϕ*

$$\mathcal{L}_\alpha[\phi](x, \sqrt{\epsilon}) = \int_{2c\sqrt{\epsilon} - \infty e^{i\alpha}}^{2c\sqrt{\epsilon} + \infty e^{i\alpha}} \phi(\xi) e^{-t(x, \epsilon)\xi} d\xi, \quad c \in (-b, a) \quad (3.4.10)$$

is analytic on the domain $\check{X}_\alpha^\pm(\Lambda, \sqrt{\epsilon})$, and is uniformly $o(|x - \sqrt{\epsilon}|^{a_1} |x + \sqrt{\epsilon}|^{b_1})$ for any $a_1 < a$, $b_1 < b$, on any sub-domain $\check{X}_\alpha^\pm(\Lambda_1, \sqrt{\epsilon})$, $\Lambda_1 > \Lambda$.

PROOF. This is a reformulation of Corollary 3.3.4, which also implies that $\mathcal{L}_\alpha[\phi]$ is $o\left(\left|\frac{x - \sqrt{\epsilon}}{x + \sqrt{\epsilon}}\right|^c\right)$ for any $-b < c < a$. \square

Definition 3.4.6 (Borel transform of x). We know from Proposition 3.4.3 that for $\sqrt{\epsilon} \neq 0$, $\mathcal{B}_\alpha^\pm[x + \sqrt{\epsilon}] = \chi_\alpha^\pm$ in the strip in between $-2\sqrt{\epsilon}$ and 0, while $\mathcal{B}_\alpha^\pm[x - \sqrt{\epsilon}] = \chi_\alpha^\pm$ in the strip in between 0 and $2\sqrt{\epsilon}$, and the function χ_α^\pm has a simple pole at 0 with residue $\operatorname{Res}_0 \chi_\alpha^\pm = \frac{\sqrt{\epsilon}}{\pi i}$, therefore

$$\mathcal{B}_\alpha^\pm[x + \sqrt{\epsilon}] - \mathcal{B}_\alpha^\pm[x - \sqrt{\epsilon}] = 2\sqrt{\epsilon} \delta_0$$

in the sense of distributions (see section 3.3.2), where δ_0 is the Dirac distribution (identity of convolution). Hence one can define the distribution

$$\mathcal{B}_\alpha^\pm[x] := \mathcal{B}_\alpha^\pm[x - \sqrt{\epsilon}] + \sqrt{\epsilon} \delta_0 = \mathcal{B}_\alpha^\pm[x + \sqrt{\epsilon}] - \sqrt{\epsilon} \delta_0.$$

Correspondingly, the convolution of $\mathcal{B}_\alpha^\pm[x]$ with a function ϕ , analytic on an open strip containing the line $e^{i\alpha}\mathbb{R}$, is then defined as

$$\begin{aligned} [\mathcal{B}_\alpha^\pm[x] * \phi]_\alpha(\xi, \sqrt{\epsilon}) &= \int_{c_1 + e^{i\alpha}\mathbb{R}} \phi(\xi - s) \chi_\alpha^\pm(s, \sqrt{\epsilon}) ds + \sqrt{\epsilon} \phi(\xi), & c_1 \in (0, 2\sqrt{\epsilon}) \\ &= \int_{c_2 + e^{i\alpha}\mathbb{R}} \phi(\xi - s) \chi_\alpha^\pm(s, \sqrt{\epsilon}) ds - \sqrt{\epsilon} \phi(\xi), & c_2 \in (-2\sqrt{\epsilon}, 0). \end{aligned}$$

3.4.1. Remark on Fourier expansions.

For $\sqrt{\epsilon} \neq 0$, we have defined the Borel transformations \mathcal{B}_α^\pm for directions transverse to $\sqrt{\epsilon}\mathbb{R}$: in fact, we have restricted ourselves to $\alpha \in (\arg \sqrt{\epsilon}, \arg \sqrt{\epsilon} + \pi)$. Let us now take a look at the direction $\arg \sqrt{\epsilon}$. So instead of integrating on a line $c^\pm + ie^{-i\alpha}\mathbb{R}$ in the t -coordinate as in Figure 3.8, this time we shall consider an integrating path $c_R + \frac{i}{\sqrt{\epsilon}}\mathbb{R}$ in the half plane $\operatorname{Re}(e^{i \arg \sqrt{\epsilon} t}) > \Lambda$ (resp. $c_L + \frac{i}{\sqrt{\epsilon}}\mathbb{R}$ in the half plane $\operatorname{Re}(e^{i \arg \sqrt{\epsilon} t}) < -\Lambda$), see Figure 3.11. If f is analytic on a neighborhood of $x = \sqrt{\epsilon}$ (resp. $x = -\sqrt{\epsilon}$), then the lifting of f to the time coordinate, $f(x(t, \epsilon))$, is $\frac{\pi i}{\sqrt{\epsilon}}$ -periodic in the half-plane $\operatorname{Re}(e^{i \arg \sqrt{\epsilon} t}) > \Lambda$ (resp. $\operatorname{Re}(e^{i \arg \sqrt{\epsilon} t}) < -\Lambda$) for Λ large enough, and can be written as a sum of its Fourier series expansion:

$$\begin{aligned} f(x) &= \sum_{n=0}^{+\infty} a_n^R e^{-2n\sqrt{\epsilon}t(x)} = \sum_{n=0}^{+\infty} a_n^R \cdot \left(\frac{x-\sqrt{\epsilon}}{x+\sqrt{\epsilon}}\right)^n, \\ \text{resp. } f(x) &= \sum_{n=0}^{+\infty} a_n^L e^{2n\sqrt{\epsilon}t(x)} = \sum_{n=0}^{+\infty} a_n^L \cdot \left(\frac{x+\sqrt{\epsilon}}{x-\sqrt{\epsilon}}\right)^n. \end{aligned}$$

The Borel transform (3.3.2) of $f(x(t, \epsilon))$ on the line $c_R + \frac{i}{\sqrt{\epsilon}}\mathbb{R}$ (resp. $c_L + \frac{i}{\sqrt{\epsilon}}\mathbb{R}$) is equal to the formal sum of distributions

$$\begin{aligned} \mathcal{B}^R[f](\xi, \sqrt{\epsilon}) &:= \frac{1}{2\pi i} \int_{c_R - \frac{i}{\sqrt{\epsilon}}\infty}^{c_R + \frac{i}{\sqrt{\epsilon}}\infty} f(x(t, \epsilon)) e^{t\xi} dt = \sum_{n=0}^{+\infty} a_n^R \delta_{2n\sqrt{\epsilon}}(\xi), \\ \text{resp. } \mathcal{B}^L[f](\xi, \sqrt{\epsilon}) &:= \frac{1}{2\pi i} \int_{c_L - \frac{i}{\sqrt{\epsilon}}\infty}^{c_L + \frac{i}{\sqrt{\epsilon}}\infty} f(x(t, \epsilon)) e^{t\xi} dt = \sum_{n=0}^{+\infty} a_n^L \delta_{-2n\sqrt{\epsilon}}(\xi). \end{aligned}$$

These transformations were studied by Sternin and Shatalov in [SS]. Let us remark that one can connect the coefficients a_n^\bullet of these expansions to residues of the unfolded Borel transforms \mathcal{B}_α^\pm , $\arg \sqrt{\epsilon} < \alpha < \arg \sqrt{\epsilon} + \pi$,

$$\begin{aligned} a_0^R &= f(\sqrt{\epsilon}), & a_n^R &= 2\pi i \operatorname{Res}_{2n\sqrt{\epsilon}} \mathcal{B}_\alpha^+[f], & n \in \mathbb{N}^*, \\ a_0^L &= f(-\sqrt{\epsilon}), & a_n^L &= 2\pi i \operatorname{Res}_{-2n\sqrt{\epsilon}} \mathcal{B}_\alpha^-[f], & n \in \mathbb{N}^*, \end{aligned}$$

(the residues of $\mathcal{B}_\alpha^+[f]$ and $\mathcal{B}_\alpha^-[f]$ at the points $\xi \in 2\sqrt{\epsilon}\mathbb{Z}$ are equal).

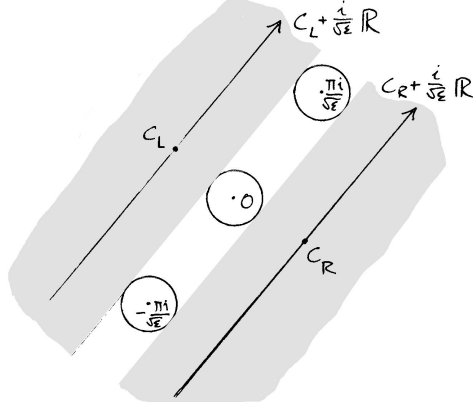

FIGURE 3.11. The integration paths $c_{\bullet} + \frac{i}{\sqrt{\epsilon}} \mathbb{R}$ ($\bullet = L, R$) in the time t -coordinate.

Remark 3.4.7. Without providing details, let us remark that one could apply these Borel transformations \mathcal{B}^R (resp. \mathcal{B}^L) to the system (3.2.11) to show the convergence of its unique local analytic solution at $x = \sqrt{\epsilon} \neq 0$ (resp. $x = -\sqrt{\epsilon} \neq 0$) to a Borel sum in direction $\arg \sqrt{\epsilon}$ of the formal solution $\hat{y}_0(x)$ of the limit system, when $\sqrt{\epsilon} \rightarrow 0$ radially in a sector not containing any eigenvalue of $M(\epsilon)$, as mentioned in Remark 3.2.6.

3.5. SOLUTION TO THE EQUATION (3.2.11) IN THE BOREL PLANE.

We will use the unfolded Borel transformation $\mathcal{B}_{\alpha}^{\pm}$ to transform the equation

$$(3.2.11) : \quad (x^2 - \epsilon) \frac{dy}{dx} = M(\epsilon) y + f(x, y, \epsilon)$$

to a convolution equation in the Borel plane (= the ξ -plane), and study its solutions there. We write the function $f(x, y, \epsilon) = O(\|y\|^2) + x O(\|y\|) + (x^2 - \epsilon) O(1)$ as

$$f(x, y, \epsilon) = \sum_{|l| \geq 2} m_l(\epsilon) y^l + x \cdot \sum_{|l| \geq 1} a_l(\epsilon) y^l + (x^2 - \epsilon) \cdot \sum_{|l| \geq 0} g_l(x, \epsilon) y^l, \quad (3.5.1)$$

where $y^l := y_1^{l_1} \cdot \dots \cdot y_m^{l_m}$ for each multi-index $l = (l_1, \dots, l_m) \in \mathbb{N}^m$, and $|l| = l_1 + \dots + l_m$.

Let a vector variable $\tilde{y} = \tilde{y}(\xi, \sqrt{\epsilon})$ correspond to the Borel transform $\mathcal{B}_{\alpha}^{\pm}[y](\xi, \sqrt{\epsilon})$, with $\alpha \in (\arg \sqrt{\epsilon}, \arg \sqrt{\epsilon} + \pi)$ if $\sqrt{\epsilon} \neq 0$. Then the equation (3.2.11) is transformed to a convolution equation in the Borel plane

$$\xi \tilde{y} = M(\epsilon) \tilde{y} + \sum_{|l| \geq 2} m_l \tilde{y}^{*l} + \tilde{h}_0^{\pm} + \sum_{|l| \geq 1} (a_l \tilde{x}^{\pm} + \tilde{h}_l^{\pm}) * \tilde{y}^{*l}, \quad (3.5.2)$$

where $\tilde{y}^{*l} := \tilde{y}_1^{*l_1} * \dots * \tilde{y}_m^{*l_m}$ is the convolution product of components of \tilde{y} , each taken l_i -times,

$$\tilde{h}_l^{\pm}(\xi, \sqrt{\epsilon}) = \mathcal{B}_{\alpha}^{\pm}[(x^2 - \epsilon) g_l](\xi, \sqrt{\epsilon}),$$

and $\tilde{x}^\pm = \mathcal{B}_\alpha^\pm[x]$ is the distribution of Definition 3.4.6. The convolutions are taken in the direction α . Let us remark that by 1) of Proposition 3.4.3, the functions $\tilde{h}_l^\pm(\xi, \sqrt{\epsilon})$ are analytic in the ξ -plane in strips passing in between the points $-2\sqrt{\epsilon}$ and $2\sqrt{\epsilon}$. In Proposition 3.5.2, we will find a unique analytic solution $\tilde{y}^\pm(\xi, \sqrt{\epsilon})$ of the convolution equation (3.5.2) as a fixed point of the operator

$$\mathcal{G}^\pm[\tilde{y}](\xi, \sqrt{\epsilon}) := (\xi I - M(\epsilon))^{-1} \cdot \left(\sum_{|l| \geq 2} m_l \tilde{y}^{*l} + \tilde{h}_0^\pm + \sum_{|l| \geq 1} (a_l \tilde{x}^\pm + \tilde{h}_l^\pm) * \tilde{y}^{*l} \right) \quad (3.5.3)$$

on a domain $\Omega(\sqrt{\epsilon})$ in the ξ -plane, obtained as union of (a bit more narrow) strips $\Omega_\alpha(\sqrt{\epsilon})$ of continuously varying direction α , that stay away from the eigenvalues of the matrix $M(\epsilon)$ as well as from all the points $\pm 2\sqrt{\epsilon}\mathbb{N}^*$ ($\mathbb{N}^* = \mathbb{N} \setminus \{0\}$); see Figure 3.12. In general, several ways of choosing such a domain $\Omega(\sqrt{\epsilon})$ are possible, depending on its position relative with respect to the eigenvalues of $M(\epsilon)$. Different choices of the domain $\Omega(\sqrt{\epsilon})$ will, in general, lead to different solutions $\tilde{y}^\pm(x, \sqrt{\epsilon})$ of (3.5.2), as shown in Example 3.5.6 below.

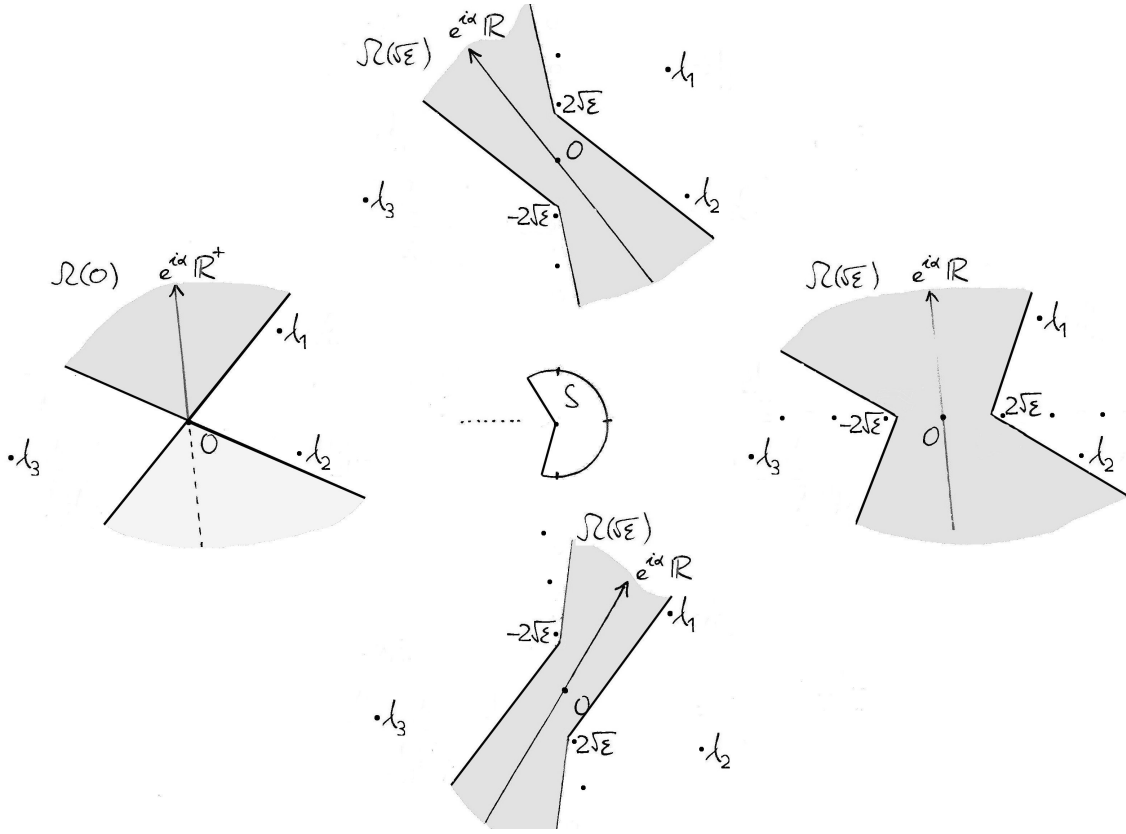

FIGURE 3.12. The regions $\Omega(\sqrt{\epsilon})$ and the eigenvalues $\lambda_1, \dots, \lambda_m$ (here $m = 3$) of $M(\epsilon)$ in the ξ -plane according to $\sqrt{\epsilon} \in S$, together with integration paths $e^{i\alpha}\mathbb{R}$ of the Laplace transformation \mathcal{L}_α .

Family of regions $\Omega(\sqrt{\epsilon})$ in the Borel plane, parametrized by $\sqrt{\epsilon} \in S$.

Let $\rho > 0$ be small enough, and let $\beta_1 < \beta_2$ be two directions, such that for $|\sqrt{\epsilon}| < \rho$ none of the closed strips

$$\Omega_\alpha(\sqrt{\epsilon}) = \bigcup_{c \in [-\frac{3}{2}\sqrt{\epsilon}, \frac{3}{2}\sqrt{\epsilon}]} c + e^{i\alpha}\mathbb{R}, \quad (3.5.4)$$

with $\alpha \in (\beta_1, \beta_2)$, contains any eigenvalue of $M(\epsilon)$. Let $0 < \eta < \frac{1}{2}(\beta_2 - \beta_1) \leq \frac{\pi}{2}$ be an arbitrarily small angle and define a family of regions $\Omega(\sqrt{\epsilon})$ in the ξ -plane depending parametrically on $\sqrt{\epsilon} \in S$ as

$$\Omega(\sqrt{\epsilon}) := \bigcup_{\alpha} \Omega_\alpha(\sqrt{\epsilon}),$$

where

$$\max\{\arg \sqrt{\epsilon} + \eta, \beta_1\} < \alpha < \min\{\beta_2, \arg \sqrt{\epsilon} + \pi - \eta\}, \quad (3.5.5)$$

and where S is a sector at the origin in the $\sqrt{\epsilon}$ -plane of opening $> \pi$, determined by (3.5.5),

$$S = \{\sqrt{\epsilon} \in \mathbb{C} \mid \arg \sqrt{\epsilon} \in (\beta_1 - \pi + \eta, \beta_2 - \eta), |\sqrt{\epsilon}| < \rho\} \cup \{0\}. \quad (3.5.6)$$

We denote Ω the union of the $\Omega(\sqrt{\epsilon})$, $\sqrt{\epsilon} \in S$, in the $(\xi, \sqrt{\epsilon})$ -space

$$\Omega := \{(\xi, \sqrt{\epsilon}) \mid \xi \in \Omega(\sqrt{\epsilon})\}. \quad (3.5.7)$$

Definition 3.5.1. Let Ω be as above, with some $\rho, \eta > 0$, and let $0 \leq \Lambda < \frac{\pi \sin \eta}{2\rho}$. For a vector function $\phi = (\phi_1, \dots, \phi_m) : \Omega \rightarrow \mathbb{C}^m$, we say that it is *analytic on Ω* , if it is continuous on Ω , analytic on the interior of Ω , and $\phi(\cdot, \sqrt{\epsilon})$ is analytic on $\Omega(\sqrt{\epsilon})$ for all $\sqrt{\epsilon} \in S$. We define the norms

$$|\phi|_\Omega^\Lambda := \max_i \sup_{\sqrt{\epsilon}, \alpha} |\phi_i|_{\Omega_\alpha(\sqrt{\epsilon})}^{A_\alpha, B_\alpha}, \quad \|\phi\|_\Omega^\Lambda := \max_i \sup_{\sqrt{\epsilon}, \alpha} \|\phi_i\|_{\Omega_\alpha(\sqrt{\epsilon})}^{A_\alpha, B_\alpha},$$

where $\sqrt{\epsilon} \in S$ and α as in (3.5.5), i.e. such that $\Omega_\alpha(\sqrt{\epsilon}) \subset \Omega(\sqrt{\epsilon})$, and $A_\alpha = e^{-i\alpha}\Lambda$, $B_\alpha = -\frac{\pi i}{\sqrt{\epsilon}} - e^{-i\alpha}\Lambda$.

Let us remark that the convolution of two analytic functions ϕ, ψ on $\Omega(\sqrt{\epsilon})$ does not depend on the direction α (3.5.5), and that the norms $|\phi * \psi|_\Omega^\Lambda, \|\phi * \psi\|_\Omega^\Lambda$ satisfy the Young's inequalities (3.3.5) and (3.3.6):

$$|\phi * \psi|_\Omega^\Lambda \leq \min \{ |\phi|_\Omega^\Lambda \cdot \|\psi\|_\Omega^\Lambda, \|\phi\|_\Omega^\Lambda \cdot |\psi|_\Omega^\Lambda \} \quad (3.5.8)$$

$$\|\phi * \psi\|_\Omega^\Lambda \leq \|\phi\|_\Omega^\Lambda \cdot \|\psi\|_\Omega^\Lambda. \quad (3.5.9)$$

Proposition 3.5.2. *Suppose that the matrix $M(\epsilon)$ and the vector function $f(x, y, \epsilon)$ in the equation (3.2.11) are analytic for*

$$x \in X(\Lambda_1, \sqrt{\epsilon}), \quad \sum_{i=1}^m |y_i| < \frac{1}{L_1}, \quad |\sqrt{\epsilon}| < \rho_1, \quad \text{for } \Lambda_1, L_1, \rho_1 > 0.$$

Then there exists $\Lambda > \Lambda_1$, $0 < \rho \leq \rho_1$, and a constant $c > 0$, such that the operator $\mathcal{G}^+ : \phi(\xi, \sqrt{\epsilon}) \mapsto \mathcal{G}^+[\phi](\xi, \sqrt{\epsilon})$ (3.5.3) is well-defined and contractive on the space

$$\{\phi : \Omega \rightarrow \mathbb{C}^m \mid \phi \text{ is analytic on } \Omega, \|\phi\|_{\Omega}^{\Lambda} \leq c, |\phi|_{\Omega}^{\Lambda} < +\infty\}$$

with respect to both the $\|\cdot\|_{\Omega}^{\Lambda}$ -norm and the $|\cdot|_{\Omega}^{\Lambda}$ -norm. Hence the equation $\mathcal{G}^+[\tilde{y}^+] = \tilde{y}^+$ possesses a unique analytic solution $\tilde{y}^+(\xi, \sqrt{\epsilon})$ on Ω , satisfying $\|\tilde{y}^+\|_{\Omega}^{\Lambda} \leq c$ and $|\tilde{y}^+|_{\Omega}^{\Lambda} < +\infty$. Similarly, the vector function $\tilde{y}^-(\xi, \sqrt{\epsilon}) := e^{\frac{\xi\pi i}{\sqrt{\epsilon}}} \cdot \tilde{y}^+(\xi, \sqrt{\epsilon})$ is a unique analytic solution of the equation $\mathcal{G}^+[\tilde{y}^-] = \tilde{y}^-$ on Ω .

To prove this proposition we will need the following technical lemmas which will allow us to estimate the norms of $\mathcal{G}^+[\phi]$.

Lemma 3.5.3. *There exists a constant $C = C(\Lambda_1, \eta) > 0$ such that, if $f \in \mathcal{O}(X(\Lambda_1, \sqrt{\epsilon}))$, $|\sqrt{\epsilon}| < \rho$, and $\Lambda_1 < \Lambda < \frac{\pi \sin \eta}{2\rho}$ (where $\eta, \rho > 0$ are as in (3.5.5), (3.5.6)), then*

$$|\mathcal{B}_{\alpha}^+[(x^2 - \epsilon)f]|_{\Omega}^{\Lambda} \leq C\rho \sup_{x \in X(\Lambda_1, \sqrt{\epsilon})} |f(x)|.$$

PROOF. By a straightforward estimation. Essentially, we need to estimate the integral $\int_{\operatorname{Re}(e^{i\alpha t})=\Lambda} \left| \frac{x-\sqrt{\epsilon}}{x+\sqrt{\epsilon}} \right|^c d|x|$, with $c \in [-\frac{3}{4}, \frac{3}{4}]$ and $\alpha \in (\arg \sqrt{\epsilon} + \eta, \arg \sqrt{\epsilon} + \pi - \eta)$. \square

Lemma 3.5.4. *Let ϕ be an analytic function on Ω with a finite $|\phi|_{\Omega}^{\Lambda}$ (resp. $\|\phi\|_{\Omega}^{\Lambda}$). Then its convolution with the distribution \tilde{x}^{\pm} is again an analytic function on Ω whose norm satisfies*

$$|\tilde{x}^{\pm} * \phi|_{\Omega}^{\Lambda} \leq |\phi|_{\Omega}^{\Lambda} \cdot \left(\rho + \|\chi_{\alpha}^{\pm}\|_{\Omega_L}^{\Lambda} \right), \quad (3.5.10)$$

$$\text{resp. } \|\tilde{x}^{\pm} * \phi\|_{\Omega}^{\Lambda} \leq \|\phi\|_{\Omega}^{\Lambda} \cdot \left(\rho + \|\chi_{\alpha}^{\pm}\|_{\Omega_L}^{\Lambda} \right), \quad (3.5.11)$$

where χ_{α}^{\pm} is given in (3.4.8), ρ is the radius of S , and

$$\Omega_L(\sqrt{\epsilon}) = \Omega(\sqrt{\epsilon}) \cap (\Omega(\sqrt{\epsilon}) - 2\sqrt{\epsilon}), \quad \text{for each } \sqrt{\epsilon} \in S. \quad (3.5.12)$$

PROOF. It follows from Definition 3.4.6 and $2\sqrt{\epsilon}$ -periodicity of χ_{α}^{\pm} . \square

Lemma 3.5.5. *If $\phi, \psi : \Omega \rightarrow \mathbb{C}^m$ are analytic vector functions such that $\|\phi\|_{\Omega}^{\Lambda}, \|\psi\|_{\Omega}^{\Lambda} \leq a$, then for any multi-index $l \in \mathbb{N}^m$, $|l| \geq 1$,*

$$|\phi^{*l} - \psi^{*l}|_{\Omega}^{\Lambda} \leq |l| \cdot a^{|l|-1} \cdot |\phi - \psi|_{\Omega}^{\Lambda}.$$

The same holds for the $\|\cdot\|_{\Omega}^{\Lambda}$ -norm as well.

PROOF. Writing $\phi^{*l} = \phi_{i_1} * \dots * \phi_{i_{|l|}}$, $i_j \in \{1, \dots, m\}$, we have

$$\begin{aligned} \phi^{*l} - \psi^{*l} &= (\phi_{i_1} - \psi_{i_1}) * \phi_{i_2} * \dots * \phi_{i_{|l|}} + \psi_{i_1} * (\phi_{i_2} - \psi_{i_2}) * \phi_{i_3} * \dots * \phi_{i_{|l|}} + \\ &\dots + \psi_{i_1} * \dots * \psi_{i_{|l|-1}} * (\phi_{i_{|l|}} - \psi_{i_{|l|}}). \end{aligned}$$

The statement now follows from the convolution inequalities (3.5.8) (resp. (3.5.9)). \square

PROOF OF PROPOSITION 3.5.2. Let $m_l(\epsilon)$, $a_l(\epsilon)$, $g_l(x, \epsilon)$ be as in (3.5.1). If $L > m \cdot L_1$, then there exists $K > 0$ such that for each multi-index $l \in \mathbb{N}^m$

$$\max\{\|m_l(\epsilon)\|, \|a_l(\epsilon)\|, \|g_l(x, \epsilon)\|\} \leq K \cdot \binom{|l|}{l} L^{|l|},$$

where for $y \in \mathbb{C}^m$, $\|y\| = \sum_{i=1}^m |y_i|$, and where $\binom{|l|}{l}$ are the multinomial coefficients given by $(y_1 + \dots + y_m)^k = \sum_{|l|=k} \binom{|l|}{l} y^l$, satisfying

$$\sum_{|l|=k} \binom{|l|}{l} = m^k.$$

It follows from Lemma 3.5.3, Lemma 3.5.4 and Lemma 3.3.3, that if $\Lambda > \Lambda_1$, then the terms of (3.5.2) can be bounded by

$$\|\tilde{h}_0^+\|_{\Omega}^{\Lambda} \leq K_1, \quad \|a_l \tilde{x}^{\pm} + \tilde{h}_l^+\|_{\Omega}^{\Lambda} \leq K_1 \cdot \binom{|l|}{l} L^{|l|},$$

for some $K_1 > 0$. Moreover, if we take Λ sufficiently large and ρ sufficiently small, then we can make the constant K_1 small enough so that it satisfies (3.5.13) below.

Let

$$\delta = \max_{(\xi, \sqrt{\epsilon}) \in \Omega} \|(I\xi - M(\epsilon))^{-1} \cdot \begin{pmatrix} 1 \\ \vdots \\ 1 \end{pmatrix}\| + \frac{1}{10mKL},$$

then $\delta < +\infty$ if the radius ρ of S is small, and let

$$c = \frac{1}{50m^2\delta KL^2} \leq \frac{1}{5mL}, \quad \text{and} \quad K_1 \leq (5cmL)^2 K \leq (5cmL)K. \quad (3.5.13)$$

First we show that $\|\phi\|_{\Omega}^{\Lambda} \leq c$ implies $\|\mathcal{G}^+[\phi]\|_{\Omega}^{\Lambda} \leq c$:

$$\begin{aligned} \|\mathcal{G}^+[\phi]\|_{\Omega}^{\Lambda} &\leq \delta \cdot \left(\sum_{k=2}^{+\infty} \sum_{|l|=k} K \binom{|l|}{l} L^{|l|} c^{|l|} + K_1 + \sum_{k=1}^{+\infty} \sum_{|l|=k} K_1 \binom{|l|}{l} L^{|l|} c^{|l|} \right) \\ &\leq \delta \cdot \left(K \sum_{k=2}^{+\infty} m^k L^k c^k + K_1 \sum_{k=0}^{+\infty} m^k L^k c^k \right) \\ &\leq \delta \cdot \left(K(5cmL)^2 \sum_{k=2}^{+\infty} \frac{1}{5^k} + K_1 \sum_{k=0}^{+\infty} \frac{1}{5^k} \right) \leq \frac{c}{2} \cdot \left(\frac{1}{20} + \frac{5}{4} \right) \leq c, \end{aligned}$$

using (3.3.6) and (3.5.13); in the first sum of the second line, we have $c^k \leq \frac{(5cmL)^2}{(5mL)^k}$ since $k \geq 2$. Similarly, $|\mathcal{G}^+[\phi]|_{\Omega}^{\Lambda} \leq \max\{c, |\phi|_{\Omega}^{\Lambda}\}$ if $\|\phi\|_{\Omega}^{\Lambda} \leq c$.

Now we show that $|\mathcal{G}^+[\phi] - \mathcal{G}^+[\psi]|_\Omega^\Lambda \leq \frac{1}{2}|\phi - \psi|_\Omega^\Lambda$ if $\|\phi\|_\Omega^\Lambda, \|\psi\|_\Omega^\Lambda \leq c$. Using Lemma 3.5.5, (3.5.13) and the convolution inequality (3.5.8), we can write

$$\begin{aligned} \frac{|\mathcal{G}^+[\phi] - \mathcal{G}^+[\psi]|_\Omega^\Lambda}{|\phi - \psi|_\Omega^\Lambda} &\leq \delta \cdot \left(\sum_{k=2}^{+\infty} \sum_{|l|=k} K \binom{|l|}{l} L^k \cdot k c^{k-1} + \sum_{k=1}^{+\infty} \sum_{|l|=k} K_1 \binom{|l|}{l} L^k \cdot k c^{k-1} \right) \\ &\leq \delta \cdot \left((5cmL)KmL \sum_{k=2}^{\infty} \frac{k}{5^{k-1}} + K_1mL \sum_{k=1}^{\infty} \frac{k}{5^{k-1}} \right) \\ &\leq 5cm^2\delta KL^2 \cdot \left(\frac{9}{16} + \frac{25}{16} \right) \leq \frac{1}{2}. \end{aligned}$$

The same holds for the $\|\cdot\|_\Omega^\Lambda$ -norm. Hence the operator \mathcal{G}^+ is $|\cdot|_\Omega^\Lambda$ -contractive, and the sequence $(\mathcal{G}^+)^n[0]$ converges, as $n \rightarrow +\infty$, $|\cdot|_\Omega^\Lambda$ -uniformly to an analytic function \tilde{y}^+ satisfying $\mathcal{G}^+[\tilde{y}^+] = \tilde{y}^+$.

From (3.4.3) it follows that $\tilde{h}_l^- = e^{\frac{\xi\pi i}{\sqrt{\epsilon}}} \cdot \tilde{h}_l^+$ and $\tilde{x}^- = e^{\frac{\xi\pi i}{\sqrt{\epsilon}}} \cdot \tilde{x}^+$, hence $\mathcal{G}^+[\tilde{y}^-] = \mathcal{G}^+[e^{\frac{\xi\pi i}{\sqrt{\epsilon}}} \tilde{y}^+] = e^{\frac{\xi\pi i}{\sqrt{\epsilon}}} \cdot \mathcal{G}^+[\tilde{y}^+] = e^{\frac{\xi\pi i}{\sqrt{\epsilon}}} \cdot \tilde{y}^+ = \tilde{y}^-$ is a fixed point of \mathcal{G}^+ . \square

The following example shows that the solutions \tilde{y}^\pm of the convolution equation (3.5.2) in the Borel plane depend on the choice of the domain Ω .

Example 3.5.6. Let u satisfy

$$(x^2 - \epsilon) \frac{du}{dx} = u + (x^2 - \epsilon), \quad (3.5.14)$$

and let $y = (x^2 - \epsilon)u$. It satisfies a differential equation

$$(x^2 - \epsilon) \frac{dy}{dx} = y + 2xy + (x^2 - \epsilon)^2. \quad (3.5.15)$$

The Borel transform of the equation (3.5.14) is

$$\xi \tilde{u}_\alpha^\pm = \tilde{u}_\alpha^\pm + \xi \cdot \chi_\alpha^\pm,$$

therefore $\tilde{u}_\alpha^\pm(\xi, \sqrt{\epsilon}) = \frac{\xi}{\xi-1} \chi_\alpha^\pm(\xi, \sqrt{\epsilon})$, which is independent of the direction α . This is no longer true for the solution $\tilde{y}_\alpha^\pm = \tilde{u}_\alpha^\pm * \mathcal{B}_\alpha^\pm[x^2 - \epsilon]$ of the Borel transform of the equation (3.5.15)

$$\xi \tilde{y}_\alpha^\pm = \tilde{y}_\alpha^\pm + 2\tilde{x}^\pm * \tilde{y}_\alpha^\pm + \chi_\alpha^\pm \cdot (\xi^3 - 4\epsilon\xi).$$

If, for instance, $\text{Im}(\sqrt{\epsilon}) < 0$, and $\arg \sqrt{\epsilon} < \alpha_1 < 0 < \alpha_2 < \arg \sqrt{\epsilon} + \pi$, then the strips $\Omega_{\alpha_1}(\sqrt{\epsilon}), \Omega_{\alpha_2}(\sqrt{\epsilon})$ (3.5.4) in directions α_1, α_2 , are separated by the point $\xi = 1$, and one easily calculates that for $\xi \in \Omega_{\alpha_1}(\sqrt{\epsilon}) \cap \Omega_{\alpha_2}(\sqrt{\epsilon})$

$$\tilde{y}_{\alpha_1}^\pm(\xi, \sqrt{\epsilon}) - \tilde{y}_{\alpha_2}^\pm(\xi, \sqrt{\epsilon}) = (\xi - 1) \chi_{\alpha_1}^\pm(1, \sqrt{\epsilon}) \chi_{\alpha_2}^\pm(\xi - 1, \sqrt{\epsilon}),$$

i.e. the two solutions $\tilde{y}_{\alpha_1}^\pm, \tilde{y}_{\alpha_2}^\pm$ differ near $\xi = 0$ by a term that is exponentially flat in $\sqrt{\epsilon}$.

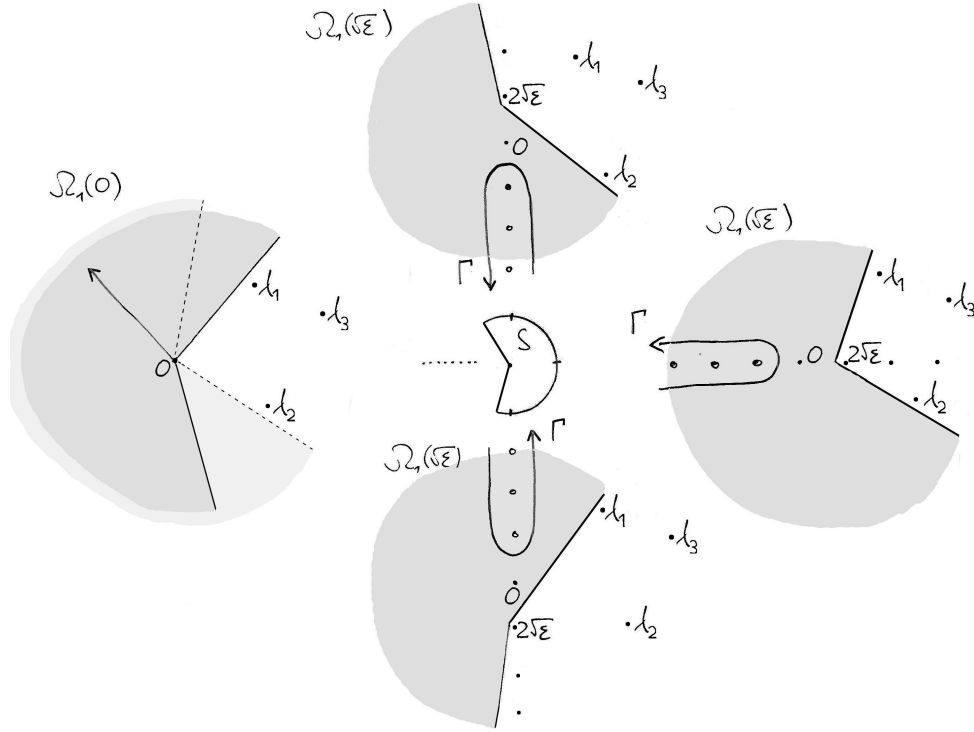

FIGURE 3.13. The extended regions $\Omega_1(\sqrt{\epsilon})$ in the Borel plane, together with the modified integration path Γ of the Laplace transform (compare with Figure 3.12). The limit region $\Omega_1(0) := \bigcup_{\sqrt{\epsilon} \in S} \bigcap_{\nu \rightarrow 0^+} \Omega_1(\nu\sqrt{\epsilon}) \setminus (-2\sqrt{\epsilon})\mathbb{N}^*$ is composed of two sectors connected at the origin; the solution $\tilde{y}^+(\xi, 0)$ vanishes on the lower sector, while the solution $\tilde{y}^-(\xi, 0)$ vanishes on the upper one.

Proposition 3.5.7. *If the spectrum of $M(0)$ is of Poincaré type, i.e. if it is contained in a sector of opening $< \pi$, then, for small $\sqrt{\epsilon}$, the region $\Omega(\sqrt{\epsilon})$ may be chosen so that it has all the eigenvalues of $M(\epsilon)$ on the same side—let's say the side where $2\sqrt{\epsilon}$ is. In such case, let $\Omega_1(\sqrt{\epsilon})$ be the extension of $\Omega(\sqrt{\epsilon})$ to the whole region on the opposite side (see Figure 3.13). The solutions $\tilde{y}^\pm(\xi, \sqrt{\epsilon})$ of Proposition 3.5.2 can be analytically extended to $\Omega_1(\sqrt{\epsilon}) \setminus (-2\sqrt{\epsilon})\mathbb{N}^*$ with at most simple poles at the points $-2\sqrt{\epsilon}\mathbb{N}^*$ (where $\mathbb{N}^* = \mathbb{N} \setminus \{0\}$). The function $\frac{\tilde{y}^\pm}{\chi^\pm}$ is analytic in Ω_1 and has at most exponential growth $< Ce^{\Lambda|\xi|}$ for some $\Lambda, C > 0$ independent of $\sqrt{\epsilon}$.*

PROOF. The solution \tilde{y}^+ is constructed as a limit of the iterative sequence of functions $(\mathcal{G}^+)^n[0]$, $n \rightarrow +\infty$. We will show by induction that for each n , the function $(\mathcal{G}^+)^n[0]$ is analytic on $\Omega_1 \setminus \{\xi \in -2\sqrt{\epsilon}\mathbb{N}^*\}$ and has at most simple poles at the points $\xi \in -2\sqrt{\epsilon}\mathbb{N}^*$, and that the sequence converges uniformly to \tilde{y}^+ with respect to the norm

$$\|\phi\|_{\Omega_1}^\Lambda := \sup_{(\xi, \sqrt{\epsilon}) \in \Omega_1} \left| \frac{\phi}{\chi^+}(\xi, \sqrt{\epsilon}) \right| e^{-\Lambda|\xi|}. \quad (3.5.16)$$

To do so we will introduce another norm $\|\cdot\|_{\Omega_1}^\Lambda$, defined in (3.5.20) below, such that the two norms satisfy convolution inequalities similar to those satisfied by $|\cdot|_\Omega^\Lambda$ and $\|\cdot\|_\Omega^\Lambda$ (Lemma 3.5.8 below). Then one can simply replicate the proof of Proposition 3.5.2 with the norm $\|\cdot\|_{\Omega_1}^\Lambda$ in place of $|\cdot|_\Omega^\Lambda$ and the norm $\|\cdot\|_{\Omega_1}^\Lambda$ in place of $\|\cdot\|_\Omega^\Lambda$.

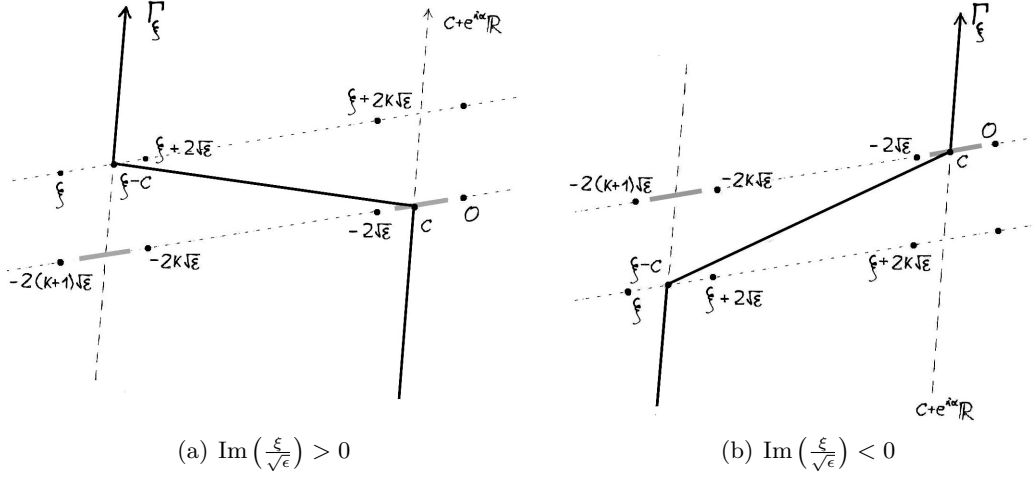

FIGURE 3.14. The integration path Γ_ξ of convolution $(\phi * \psi)(\xi)$, $\xi \in \Omega_1(\sqrt{\epsilon})$.

Let us first show that if ϕ, ψ are two functions analytic on $\Omega_1(\sqrt{\epsilon}) \setminus (-2\sqrt{\epsilon}\mathbb{N}^*)$, then so is their convolution $\phi * \psi$. If $\xi \in \Omega_1(\sqrt{\epsilon}) \setminus \sqrt{\epsilon}\mathbb{R}$, then the analytic continuation of $\phi * \psi$ at the point ξ is given by the integral

$$(\phi * \psi)(\xi) = \int_{\Gamma_\xi} \phi(s) \psi(\xi - s) ds$$

with Γ_ξ a symmetric path with respect to the point $\frac{\xi}{2}$ passing through the segments $[-\frac{3}{2}\sqrt{\epsilon}, \frac{3}{2}\sqrt{\epsilon}]$ and $[\xi - \frac{3}{2}\sqrt{\epsilon}, \xi + \frac{3}{2}\sqrt{\epsilon}]$, as in Figure 3.14. Note that when ξ approaches a point on $(-\infty\sqrt{\epsilon}, -2\sqrt{\epsilon}) \setminus (-2\sqrt{\epsilon}\mathbb{N}^*)$ from one side or another, the values of the two integrals are identical, since both paths Γ_ξ pass in between the same singularities.

Suppose now that ϕ, ψ have at most simple poles at the points $-2\sqrt{\epsilon}\mathbb{N}^*$. If ξ is in $\Omega(\sqrt{\epsilon}) \cup 2\Omega_L(\sqrt{\epsilon})$ (Ω_L is defined in (3.5.12)), then $\Gamma_\xi = c + e^{i\alpha}\mathbb{R}$ for some $c \in [-\frac{3}{2}\sqrt{\epsilon}, -\frac{1}{2}\sqrt{\epsilon}] \subset \Omega_L(\sqrt{\epsilon})$. Else $\xi \in 2\Omega_L(\sqrt{\epsilon}) - 2k\sqrt{\epsilon}$ for some $k \in \mathbb{N}^*$, and one can express the convolution as

$$(\phi * \psi)(\xi) = \int_{c-2k\sqrt{\epsilon}+e^{i\alpha}\mathbb{R}} \phi(s) \psi(\xi - s) ds + 2\pi i \sum_{j=1}^k \text{Res}_{-2j\sqrt{\epsilon}} \phi \cdot \psi(\xi + 2j\sqrt{\epsilon})$$

$$= \int_{c+e^{i\alpha}\mathbb{R}} \phi(t-2k\sqrt{\epsilon}) \psi(\xi_0-t) dt - 2\sqrt{\epsilon} \sum_{j=0}^{k-1} \frac{\phi}{\chi^+}(-2(k-j)\sqrt{\epsilon}) \cdot \psi(\xi_0-2j\sqrt{\epsilon}), \quad (3.5.17)$$

where $c \in [-\frac{3}{2}\sqrt{\epsilon}, -\frac{1}{2}\sqrt{\epsilon}] \subset \Omega_L(\sqrt{\epsilon})$ and $\xi_0 = \xi + 2k\sqrt{\epsilon} \in c + \Omega_L(\sqrt{\epsilon})$, i.e. $\xi - s \in \Omega_L(\sqrt{\epsilon})$, see Figure 3.14. We will use this formula to obtain an estimate for the norm $\|\phi * \psi\|_{\Omega_1}^\Lambda$, $\Lambda \geq 0$. Since $|\frac{1}{\chi^+(\xi, \sqrt{\epsilon})}| \leq (1 + |e^{\frac{s\pi i}{\sqrt{\epsilon}}}|)(1 + |e^{\frac{(\xi-s)\pi i}{\sqrt{\epsilon}}}|)$, cf. (3.3.4), we have

$$\begin{aligned} \left| \frac{\phi * \psi}{\chi^+}(\xi) \right| e^{-\Lambda|\xi|} &\leq \sup_{s \in \Omega_L(\sqrt{\epsilon}) - 2k\sqrt{\epsilon}} |\phi(s)| (1 + |e^{\frac{s\pi i}{\sqrt{\epsilon}}}|) e^{-\Lambda|s|} \cdot \|\psi\|_{\Omega(\sqrt{\epsilon})}^\Lambda \\ &\quad + 2\sqrt{|\epsilon|} \cdot \|\phi\|_{\Omega_1}^\Lambda \cdot \sum_{j=0}^{k-1} \left| \frac{\psi}{\chi^+}(\xi_0 - 2j\sqrt{\epsilon}) \right| e^{-\Lambda|\xi_0 - 2j\sqrt{\epsilon}|}, \end{aligned} \quad (3.5.18)$$

due to the $2\sqrt{\epsilon}$ -periodicity of χ^+ .

Let $\mu \geq 1$ be such that

$$1 + |e^{\frac{s\pi i}{\sqrt{\epsilon}}}| \leq \mu \left| \frac{1}{\chi^+(s, \sqrt{\epsilon})} \right| \quad \text{for all } s \in \Omega_L(\sqrt{\epsilon}) \quad (3.5.19)$$

and define

$$\mathbf{\Psi} \|\psi\|_{\Omega_1}^\Lambda := \mu \|\psi\|_{\Omega}^\Lambda + \sup_{\substack{\sqrt{\epsilon} \in S \\ \xi \in 2\Omega_L(\sqrt{\epsilon})}} 2\sqrt{|\epsilon|} \sum_{k=0}^{+\infty} \left| \frac{\psi}{\chi^+}(\xi - 2k\sqrt{\epsilon}) \right| e^{-\Lambda|\xi - 2k\sqrt{\epsilon}|}. \quad (3.5.20)$$

Then (3.5.18) implies that

$$\|\phi * \psi\|_{\Omega_1}^\Lambda \leq \|\phi\|_{\Omega_1}^\Lambda \cdot \mathbf{\Psi} \|\psi\|_{\Omega_1}^\Lambda.$$

Note that by 4) of Proposition 3.4.3, if $\frac{f(x, \epsilon)}{x^2 - \epsilon}$ is analytic on $\{|x^2 - \epsilon| < r^2\} \times \{|\epsilon| < \rho^2\}$ for some $r > 2\rho > 0$, then for any $\Lambda > \frac{1}{r-2\rho}$

$$\|\mathcal{B}_\alpha[f]\|_{\Omega_1}^\Lambda < +\infty, \quad \mathbf{\Psi} \|\mathcal{B}_\alpha^+[f]\|_{\Omega_1}^\Lambda < +\infty,$$

and one can see that $\mathbf{\Psi} \|\mathcal{B}_\alpha[f]\|_{\Omega_1}^\Lambda$ can be made arbitrarily small taking Λ sufficiently large (cf. Lemma 3.3.3). \square

Lemma 3.5.8. *Let $\frac{\phi}{\chi^+}, \frac{\psi}{\chi^+}$ be analytic functions on Ω_1 such that $\frac{\phi}{\chi^+}(0, \sqrt{\epsilon}) = \frac{\psi}{\chi^+}(0, \sqrt{\epsilon}) = 0$. Then*

$$\begin{aligned} \|\phi * \psi\|_{\Omega_1}^\Lambda &\leq \|\phi\|_{\Omega_1}^\Lambda \cdot \mathbf{\Psi} \|\psi\|_{\Omega_1}^\Lambda, \\ \mathbf{\Psi} \|\phi * \psi\|_{\Omega_1}^\Lambda &\leq \mathbf{\Psi} \|\phi\|_{\Omega_1}^\Lambda \cdot \mathbf{\Psi} \|\psi\|_{\Omega_1}^\Lambda. \end{aligned}$$

PROOF. The first inequality is given in the proof of Lemma 3.5.7. We need to prove the second one. By definition

$$\|\phi * \psi\|_{\Omega_1}^\Lambda = \mu \|\phi * \psi\|_{\Omega}^\Lambda + \sup_{\substack{\sqrt{\epsilon} \in S \\ \xi \in 2\Omega_L(\sqrt{\epsilon})}} 2\sqrt{|\epsilon|} \sum_{k=0}^{+\infty} \left| \frac{\phi * \psi}{\chi^+}(\xi - 2k\sqrt{\epsilon}) \right| e^{-\Lambda|\xi - 2k\sqrt{\epsilon}|}.$$

The first term is smaller than

$$\mu \|\phi\|_{\Omega}^\Lambda \|\psi\|_{\Omega}^\Lambda \leq \mu^2 \|\phi\|_{\Omega}^\Lambda \|\psi\|_{\Omega}^\Lambda \quad \text{since } \mu \geq 1.$$

For the second term, using (3.5.17), (3.5.19) and $2\sqrt{\epsilon}$ -periodicity of χ^+ , we have

$$\begin{aligned} & \sum_{k=0}^{+\infty} \left| \frac{\phi * \psi}{\chi^+}(\xi - 2k\sqrt{\epsilon}) \right| e^{-\Lambda|\xi - 2k\sqrt{\epsilon}|} \\ & \leq \int_{c+e^{i\alpha}\mathbb{R}} \mu \cdot \sum_{k=0}^{+\infty} \left| \frac{\phi}{\chi^+}(t - 2k\sqrt{\epsilon}) \right| e^{-\Lambda|t - 2k\sqrt{\epsilon}|} \cdot \left(|\psi(\xi - t)| \left(1 + \left| e^{\frac{(\xi-t)\pi i}{\sqrt{\epsilon}}} \right| \right) e^{-\Lambda|\xi - t|} \right) dt + \\ & \quad + 2\sqrt{|\epsilon|} \sum_{k=0}^{+\infty} \sum_{j=1}^k \left| \frac{\phi}{\chi^+}(-2j\sqrt{\epsilon}) \right| e^{-\Lambda|2j\sqrt{\epsilon}|} \cdot \left| \frac{\psi}{\chi^+}(\xi - 2(k-j)\sqrt{\epsilon}) \right| e^{-\Lambda|\xi - 2(k-j)\sqrt{\epsilon}|} \\ & \leq \sup_{\xi \in 2\Omega_L(\sqrt{\epsilon})} \sum_{k=0}^{+\infty} \left| \frac{\phi}{\chi^+}(\xi - 2k\sqrt{\epsilon}) \right| e^{-\Lambda|\xi - 2k\sqrt{\epsilon}|} \cdot \\ & \quad \cdot \left(\mu \|\psi\|_{\Omega}^\Lambda + \sup_{\xi \in 2\Omega_L(\sqrt{\epsilon})} 2\sqrt{|\epsilon|} \sum_{j=0}^{+\infty} \left| \frac{\psi}{\chi^+}(\xi - 2j\sqrt{\epsilon}) \right| e^{-\Lambda|\xi - 2j\sqrt{\epsilon}|} \right). \end{aligned}$$

□

PROOF OF THEOREM 3.2.4. *i)* Let $\tilde{y}^\pm(\xi, \sqrt{\epsilon})$ be the solution of the convolution equation (3.5.2) of Proposition 3.5.2 on Ω with bounded $\|\cdot\|_{\Omega}^\Lambda$ -norm. Its Laplace transform

$$y^\pm(x, \sqrt{\epsilon}) := \mathcal{L}[\tilde{y}^\pm](x, \sqrt{\epsilon}) = \int_{-\infty e^{i\alpha}}^{+\infty e^{i\alpha}} \tilde{y}^\pm(\xi, \sqrt{\epsilon}) e^{-t(x, \epsilon)\xi} d\xi, \quad (3.5.21)$$

where α can vary as in (3.5.5), is a solution of (3.5.1) defined for $x \in \bigcup_\alpha \check{X}_\alpha^\pm(\Lambda, \sqrt{\epsilon})$, (see Figure 3.3 for the domain of convergence in the time $t(x)$ -coordinate). Both y^+ and y^- project to the same ramified solution on a domain $Z(\sqrt{\epsilon})$ in the x -plane (Figure 3.2).

ii) If the spectrum of $M(0)$ is of Poincaré type and $\tilde{y}^\pm(\xi, \sqrt{\epsilon})$ is defined on Ω_1 as in Proposition 3.5.7, with $\|\tilde{y}^+\|_{\Omega_1}^\Lambda < +\infty$, then, for $x \in Z_1(\sqrt{\epsilon}) \cap \{\operatorname{Re}(e^{i \arg \sqrt{\epsilon}} t(x, \epsilon)) < -\Lambda\}$, one may deform the integration path of the Laplace transform (3.5.21) to Γ , indicated in Figure 3.13, and use the Cauchy formula to express $y^\pm(x, \sqrt{\epsilon})$, for

$\sqrt{\epsilon} \neq 0$, as a sum of residues at the points $\xi = -2k\sqrt{\epsilon}$, $k \in \mathbb{N}^*$,

$$\begin{aligned} y^\pm(x, \sqrt{\epsilon}) &= \int_{\Gamma} \tilde{y}^\pm(\xi, \sqrt{\epsilon}) e^{-t(x,\epsilon)\xi} d\xi = 2\pi i \sum_{k=1}^{\infty} \text{Res}_{-2k\sqrt{\epsilon}} \tilde{y}^\pm \cdot \left(\frac{x+\sqrt{\epsilon}}{x-\sqrt{\epsilon}}\right)^k \\ &= -2\sqrt{\epsilon} \sum_{k=1}^{\infty} \left(\frac{\tilde{y}^\pm}{\chi^\pm}\right)(-2k\sqrt{\epsilon}, \sqrt{\epsilon}) \cdot \left(\frac{x+\sqrt{\epsilon}}{x-\sqrt{\epsilon}}\right)^k. \end{aligned} \quad (3.5.22)$$

This series is convergent for $\left|\frac{x+\sqrt{\epsilon}}{x-\sqrt{\epsilon}}\right| < e^{-2\sqrt{|\epsilon|\Lambda}}$, and its coefficients are the same in both cases \tilde{y}^+ and \tilde{y}^- . It defines a solution $y_1(x, \sqrt{\epsilon})$ of (3.2.11) on a domain $Z_1(\sqrt{\epsilon})$, analytic at $x = -\sqrt{\epsilon}$ and ramified at $x = \sqrt{\epsilon}$ (Figure 3.4). \square

CONCLUSION

The article [K1], presented in Chapter 2, is part of the large program of explaining the geometric meaning of analytic invariants of irregular singularities of linear differential systems by unfolding the systems. It shows that the program can also be performed for resonant singularities when there is a change of the order of summability. The thesis provides full analytic classification of germs of parametric systems unfolding a generic resonant singularity of Poincaré rank $k = 1$ in dimension $n = 2$. The analytic classification of parametric systems unfolding a non-resonant irregular singularity of arbitrary Poincaré rank k in any dimension n has been achieved in [HLR]. There are several possibilities of generalization. The next step may be to provide an analytic classification of parametric systems unfolding a generic resonant singularity with, for example,

- Poincaré rank $k > 1$ and dimension $n = 2$,
- Poincaré rank $k = 1$ and dimension $n > 2$, whose leading matrix has a single Jordan bloc,
- Poincaré rank $k = 1$ and dimension $n > 2$, whose leading matrix has one double eigenvalue in 2×2 -Jordan bloc and other eigenvalues simple.

The general strategy should be the same: First, one needs to determine formal invariants and construct sectorial normalizing transformations between formally equivalent systems (as in Theorem III in section 2.2.2). We know from the previous studies ([LR], [HLR], [K1], [K2]) that the domains on which such transformations exist are obtained as unions of real trajectories of a certain polynomial, or rational, vector field on $\mathbb{C}\mathbb{P}^1$. Then one has to identify the modulus of analytic equivalence. We should remark here that the situation of Theorem I (in section 2.2.1 of the present study), where there is just a single analytic invariant, which can be easily calculated from the monodromy, is very special to the particular case studied here. In the more general situations mentioned above, when $k > 1$ or $n > 2$, there will be at least $(kn - 1)(n - 1)$ analytic invariants needed, and thus the modulus will have to be described in terms of equivalence of certain Stokes data (i.e. set of transition matrices between canonical fundamental matrix solutions). A natural way of considering such

Stokes data is as representing some kind of “cocycle” of automorphisms of a system in a formal normal form. Finally, one has to identify which moduli are realizable by an analytic family of systems; and possibly provide analytic normal forms (this last problem is however still open even for non-resonant irregular singularities of single (non-parametric) systems in dimensions $n \geq 4$).

An interesting question that comes to one’s mind is that of whether Corollary 2.2.6 stays valid also in more general situations:

Considering two families of systems depending on the same parameter, if the systems restricted to each parameter value are analytically equivalent on some open set independent of the parameter, does that imply that they are also equivalent as parametric families on that set?

The second article [K2], presented in Chapter 3, shows that it is possible to unfold the Borel-Laplace correspondence. In the literature the classical Borel-Laplace transform can take two forms: it could be a correspondence between sets of functions defined on sectors or a correspondence between a set of formal series and a set of convergent series. Unfolding the second form with parameters in a general setting is an interesting challenge. There are also some smaller questions more closely related to the article itself that deserve to be considered. For instance, it remains to describe what is the relation between the different solutions of the transformed equation (3.5.1) in the Borel plane corresponding to different choices of the domain Ω ? We know that at the limit, for $\sqrt{\epsilon} = 0$, they are just analytic extensions of the same function—the Borel transform of the unique formal solution $\hat{y}_0(x)$ of the limit system (3.2.11) defined on a neighborhood of $\xi = 0$.

Another problem is to generalize the present construction for saddle-node singular points of multiplicity $k + 1$ (which are points with one zero eigenvalue), $k > 1$, i.e. to unfold the k -summation. Again, the corresponding unfolded Borel-Laplace transformations should be associated to the universal unfolding of the vector field $x^{k+1} \frac{\partial}{\partial x}$ (let us mention that such polynomial complex vector fields in \mathbb{C} have been studied in the seminal work of A. Douady and P. Sentenac [DES], see also [BD]). Possible difficulties may come from the more complicated geometry of the Riemann surface of the time function of such unfolded vector field.

We hope to address some of these problems in the near future.

BIBLIOGRAPHY

- [Ar] V.I. Arnold, *On matrices depending on parameters*, Russian Math. Surveys **26** (1971), 29–43.
- [BV] D.G. Babbitt, V.S. Varadarajan, *Local moduli for meromorphic differential equations*, Astérisque **169-170** (1989).
- [Ba] W. Balsler, *Formal power series and linear systems of meromorphic ordinary differential equations*, Springer, (2000).
- [BJL1] W. Balsler, W.B. Jurkat, D.A. Lutz, *Birkhoff Invariants and Stokes' Multipliers for Meromorphic Linear Differential Equations*, J. Math. Anal. Appl. **71** (1979), 48–94.
- [BJL2] W. Balsler, W.B. Jurkat, D.A. Lutz, *A general theory of invariants for meromorphic differential equations. Part I, Formal invariants. Part II, Proper invariants*, Funkcial. Ekvac. **22** (1979), 197–221, 257–283.
- [Br] B.L.J. Braaksma, *Laplace integrals in singular differential and difference equations*. In: *Proc. Conf. Ordinary and Partial Diff. Eq., Dundee 1978*, Lect. Notes Math. **827**, Springer-Verlag (1980), 25–53.
- [BD] B. Branner, K. Dias, *Classification of complex polynomial vector fields in one complex variable*, J. Diff. Eq. Appl., **16** (2010), 463–517.
- [Bre] H. Bremermann, *Distributions, Complex variables, and Fourier Transforms*, Addison-Wesley Publ. Comp., (1965).
- [Co] O. Costin, *On Borel summation and Stokes phenomena for rank-1 nonlinear systems of ordinary differential equations*, Duke Math. J. **93** (1998), 289–344.
- [Do] G. Doetsch, *Introduction to the Theory and Application of the Laplace Transformation*, Springer, (1974).
- [DES] A. Douady, F. Estrada, P. Sentenac, *Champs de vecteurs polynômiaux sur \mathbb{C}* , unpublished manuscript, (2005).
- [Du] A. Duval, *Biconfluence et groupe de Galois*, J. Fac. Sci. Univ. Tokyo, Sect. IA, Math. **38** (1991), 211–223.
- [Ec] J. Écalle, *Les fonctions réurgentes I, II, III*, Publ. Math. d'Orsay, Paris, (1981–1985).
- [G1] A. Glutsyuk, *Stokes Operators via Limit Monodromy of Generic Perturbation*, J. Dynam. Control Syst. **5** (1999), 101–135.
- [G2] A. Glutsyuk, *Confluence of singular points and the nonlinear Stokes phenomena*, Transactions Moscow Math. Soc **62** (2001), 49–95.

- [G3] A. Glutsyuk, *Resonant Confluence of Singular Points and Stokes Phenomena*, J. Dynam. Contr. Syst. **10** (2004), 253–302.
- [G4] A. Glutsyuk, *Confluence of singular points and Stokes phenomena*. In: *Normal forms, bifurcations and finiteness problems in differential equations*, NATO Sci. Ser. II Math. Phys. Chem. **137**, Kluwer Acad. Publ. (2004).
- [HLR] J. Hurtubise, C. Lambert, C. Rousseau, *Complete system of analytic invariants for unfolded differential linear systems with an irregular singularity of Poincaré rank k* , preprint (2013), to appear in Moscow Math. J.
- [IY] Y. Ilyashenko, S. Yakovenko, *Lectures on Analytic Differential Equations*, Graduate Studies in Mathematics **86**, Amer. Math. Soc., Providence, (2008).
- [JLP1] W.B. Jurkat, D.A. Lutz, A. Peyerimhoff, *Birkhoff invariants and effective calculations for meromorphic linear differential equations I*, J. Math. Anal. Appl. **53** (1976), 438–470.
- [JLP2] W.B. Jurkat, D.A. Lutz, A. Peyerimhoff, *Birkhoff invariants and effective calculations for meromorphic linear differential equations II*, Houston J. Math. **2** (1976), 207–238.
- [K1] M. Klimeš, *Analytic classification of families of linear differential systems unfolding a resonant irregular singularity*, preprint arXiv:1301.5228 (2013).
- [K2] M. Klimeš, *Confluence of singularities of non-linear differential equations via Borel-Laplace transformations*, preprint arXiv:1307.8383 (2013).
- [Ko] V.P. Kostov, *Normal forms of unfoldings of non-fuchsian systems*, C. R. Acad. Sc. Paris **318** (1994), 623–628.
- [LR] C. Lambert, C. Rousseau, *Complete system of analytic invariants for unfolded differential linear systems with an irregular singularity of Poincaré rank 1*, Moscow Math. J. **12** (2012), 77–138.
- [Ma1] B. Malgrange, *Remarques sur les équations différentielles à points singuliers irréguliers*, in: *Équations différentielles et systèmes de Pfaff dans le champ complexe*, Lect. Notes in Math. **712**, Springer, (1979).
- [Ma2] B. Malgrange, *Sommation des séries divergentes*, Expositiones Mathematicae **13** (1995), 163–222.
- [MaR] B. Malgrange, J.-P. Ramis, *Fonctions multisommables*, Ann. Inst. Fourier, Grenoble **42** (1992), 353–368.
- [Mlm] J. Malmquist, *Sur l'étude analytique des solutions d'un système d'équations différentielles dans le voisinage d'un point singulier d'indétermination*, Acta Math. **73** (1941), 87–129.
- [M] J. Martinet, *Remarques sur la bifurcation nœud-col dans le domaine complexe*, Astérisque **150-151** (1987), 131–149.
- [MR1] J. Martinet, J.-P. Ramis, *Problèmes de modules pour des équations différentielles non linéaires du premier ordre*, Publ. IHES **55** (1982), 63–164.
- [MR2] J. Martinet, J.-P. Ramis, *Théorie de Galois différentielle et resommation*, in: *Computer Algebra and Differential Equations* (E.Tournier ed.), Acad. Press, (1988).

- [MR3] J. Martinet, J.-P. Ramis, *Elementary acceleration and multisummability*, Ann. Inst. H. Poincaré, Phys. Th. **54-1** (1991), 1–71.
- [Ra1] J.-P. Ramis, *Phénomène de Stokes et resommation*, C. R. Acad. Sc. Paris **301** (1985), 99–102.
- [Ra2] J.-P. Ramis, *Confluence and resurgence*, J. Fac. Sci. Univ. Tokyo, Sec. IA **36** (1989), 703–716.
- [Ra3] J.-P. Ramis, *Séries divergentes et théories asymptotiques*, Bull. Soc. Math. France **121** (1993), Panoramas et Synthèses.
- [R] C. Rousseau, *Modulus of orbital analytic classification for a family unfolding a saddle-node*, Moscow Math. J. **5** (2005), 245–268.
- [RT] C. Rousseau, L. Teyssier, *Analytical moduli for unfoldings of saddle-node vector fields*, Moscow Math. J. **8** (2008), 547–614.
- [Si1] Y. Sibuya, *Stokes phenomena*, Bull. Amer. Math. Soc. **83** (1977), 1075–1077.
- [Si2] Y. Sibuya, *Linear differential equations in the complex domain : problems of analytic continuation*, Translations of Mathematical Monographs **82**, Amer. Math. Soc., Providence, (1990).
- [SS] Yu. Sternin, V.E. Shatalov, *On the Confluence phenomenon of Fuchsian equations*, J. Dynam. Control Syst. **3** (1997), 433–448.
- [Va] V.S. Varadarajan, *Linear Meromorphic Differential Equations: a Modern Point of View*, Bull. Amer. Math. Soc. **33** (1996), 1–42.
- [Wa] W. Wasow, *Asymptotic Expansions for Ordinary Differential Equations*, John Wiley and Sons Inc., (1966).
- [Zo] H. Żołądek, *The Monodromy Group*, Birkhäuser Verlag, Basel, (2006).