

# An Axiomatization of the Serial Cost-Sharing Method

Yves Sprumont\*

December 28, 2009

## Abstract

We offer an axiomatization of the serial cost-sharing method of Friedman and Moulin (1999). The key property in our axiom system is Group Demand Monotonicity, asking that when a group of agents raise their demands, not all of them should pay less.

*JEL classification:* C 71, D 63

*Keywords:* Cost sharing, Serial method, Group Demand Monotonicity, Shapley value

## 1. Introduction

Serial cost sharing was proposed by Moulin and Shenker (1992) as a method for allocating the cost of production of a single good among  $n$  agents. Friedman and Moulin (1999) generalized it to the context where each agent consumes a possibly different good: total cost varies with the consumption profile but need no longer be a function of the sum of the agents' consumptions. The problem is to allocate the cost  $C(x)$  generated by the demand profile  $x = (x_1, \dots, x_n)$  based on the knowledge of  $x$  and the information contained in the cost function  $C$  defined on  $\mathbb{R}_+^n$ , which is assumed to be nondecreasing, continuously differentiable, and to display no fixed costs. This is the standard cost-sharing model developed by Billera and Heath (1982), Mirman and Tauman (1982), and Samet and Tauman (1982). Assuming without loss of generality that  $x_1 \leq x_2 \leq \dots \leq x_n$ , Friedman and Moulin's serial method charges agent  $i$  the integral of her marginal cost along the "constrained egalitarian path" made up of the line segments linking 0 to  $(x_1, \dots, x_1)$  to  $(x_1, x_2, \dots, x_2)$ , and so on to  $x$ . This is an alternative to the better known method derived from the Aumann-Shapley (1974) value for nonatomic games, which integrates marginal costs along the diagonal from 0 to  $x$ .

---

\*Département de Sciences Economiques and CIREQ, Université de Montréal, C.P. 6128, succursale centre-ville, Montréal H3C 3J7, Canada (yves.sprumont@umontreal.ca). Many thanks to M. Amaranante and S. Gordon for very useful discussions. This research was supported by Canada's SSHRC and Québec's FQRSC.

Friedman and Moulin (1999) proposed an axiomatization of their method. A key axiom in their work states that if all goods are perfect substitutes –that is,  $C(z) = c(\sum_{i \in N} z_i)$ – then an agent’s cost share should not exceed the cost of producing  $n$  times her own demand. This condition offers a protection against the risk of paying an exceedingly high cost share because of the much higher demands of others. It is certainly in the original spirit of the serial method but remains perhaps too reminiscent of the very definition of the method to provide an independent justification for it.

Our purpose is to offer an alternative axiomatization providing such a justification. The general normative principle motivating our choice of axioms is the one that underlies most of the theory of cost sharing: an agent should pay –fully but only– the fraction of the cost generated by her own demand<sup>1</sup>. Of course, unless the cost function is additively separable, this general principle is ambiguous. The challenge is to formulate unambiguous statements that capture the essential aspects of it.

In order to do that, we find it useful to break down an agent’s influence on total cost into two components: the marginal cost function associated with the good she consumes and the size of her demand. If agents must be charged “the cost of their demand”, then cost shares should somehow

- (a) be positively associated with marginal cost functions,
- (b) be positively associated with demand sizes,
- (c) be independent of any cost-irrelevant information.

With one exception –Additivity–, our axioms are meant to be unambiguous statements interpreting these three desiderata. Of course, desideratum (b) is compelling only when each good is consumed by a clearly identifiable agent who can be held responsible for the entire demand of that good. That is the interpretation of the cost-sharing model we have in mind<sup>2</sup>.

The first component of our axiom system is nothing more than the extension to the cost-sharing model of the system used by Shapley (1953) to characterize the value: Additivity (cost shares depend additively on the cost function), Dummy (an agent pays nothing if total cost never increases with her consumption), and Anonymity (the identity of an agent does not affect what she pays). If Additivity is used for tractability –the world of nonadditive methods is virtually uncharted territory that we do not want to venture into–, the other two axioms follow naturally from desiderata (a) and (c) above. Dummy is a minimal expression of the view that cost shares should be positively related to marginal cost functions and Anonymity follows from the principle forbidding the use of cost-irrelevant information. As a matter of fact, we do employ a strengthened version of the Dummy axiom requiring also that a change in the demand of a dummy agent should have no effect on cost shares. This requirement too follows naturally from (c).

---

<sup>1</sup>There are contexts where this “full responsibility” principle is not warranted: see Moulin and Sprumont (2006) for a discussion and an alternative view.

<sup>2</sup>A good example is the problem of allocating overhead costs among the various divisions of a large firm (Shubik (1962)). Desideratum (b) is not compelling when the demand for a given good results from the aggregation of many small individual demands, as in the telephone pricing problem studied by Billera, Heath and Raanan (1978) and other applications of Aumann-Shapley pricing.

The second important component of our axiom system, Group Demand Monotonicity, follows from desideratum (b). This axiom, introduced by Moulin and Sprumont (2005), says that when a group of agents raise their demands, not all of them should end up paying less. This seems to be a rather weak form of the idea that cost shares should be positively related with demand sizes.

The model, the axioms, and our theorem are presented in Section 2. The proof is given in Section 3. A discussion of our result and further comparison with related work is offered in Section 4.

## 2. The model and the result

Let  $N = \{1, \dots, n\}$  be a finite set of agents,  $n \geq 3$ . A *cost function* is a mapping  $C : \mathbb{R}_+^N \rightarrow \mathbb{R}_+$  that is nondecreasing, continuously differentiable, and satisfies  $C(0) = 0$ . The set of cost functions is denoted  $\mathcal{C}$ . A *demand profile* is a point  $x \in \mathbb{R}_+^N$ . A (*cost-sharing*) *method* is a mapping  $\varphi$  which assigns to each (*cost-sharing*) *problem*  $(C, x) \in \mathcal{C} \times \mathbb{R}_+^N$  a vector of nonnegative cost shares  $\varphi(C, x) \in \mathbb{R}_+^N$  satisfying the *budget balance* condition  $\sum_{i \in N} \varphi_i(C, x) = C(x)$ .

As is well known, this model can be reinterpreted as a surplus-sharing model:  $C$  is then viewed as a production function,  $x_i$  is agent  $i$ 's input contribution and  $\varphi_i(C, x)$  is her share of the total output produced. All our axioms remain meaningful under this alternative interpretation. We maintain the cost-sharing interpretation throughout the rest of the paper to avoid confusion.

If  $C \in \mathcal{C}$  and  $i \in N$ , we denote by  $\partial_i C(z)$  the  $i$ th partial derivative of  $C$  at  $z$  if  $z_i > 0$  and its  $i$ th right partial derivative at  $z$  if  $z_i = 0$ . For all  $z, z' \in \mathbb{R}_+^N$ , we let  $z \wedge z' = (\min(z_1, z'_1), \dots, \min(z_n, z'_n))$ . The (*Friedman-Moulin*) *serial method* is the cost-sharing method  $\varphi^*$  defined by

$$\varphi_i^*(C, x) = \int_0^{x_i} \partial_i C((\alpha, \alpha, \dots, \alpha) \wedge x) d\alpha \quad (2.1)$$

for all  $C \in \mathcal{C}$ ,  $x \in \mathbb{R}_+^N$ , and  $i \in N$ . This method reduces to the well known serial formula proposed by Moulin and Shenker (1992) in the particular case of perfectly substitutable goods. If there exists a function  $c : \mathbb{R}_+ \rightarrow \mathbb{R}_+$  such that  $C(z) = c(\sum_{i \in N} z_i)$  for all  $z \in \mathbb{R}_+^N$ , then, assuming without loss of generality that  $x_1 \leq x_2 \leq \dots \leq x_n$ , the cost shares in (2.1) become  $\varphi_1^*(C, x) = \frac{c(nx_1)}{n}$ ,  $\varphi_2^*(C, x) = \frac{c(nx_1)}{n} + \frac{c(x_1+(n-1)x_2)-c(nx_1)}{n-1}$ , ...  $\varphi_n^*(C, x) = \frac{c(nx_1)}{n} + \frac{c(x_1+(n-1)x_2)-c(nx_1)}{n-1} + \dots + \frac{c(x_1+\dots+x_n)-c(x_1+\dots+x_{n-2}+2x_{n-1})}{1}$ .

Just like the Aumann-Shapley method, the serial method belongs to the class of “path-generated methods” (Friedman (2004)). To make the comparison precise, rewrite agent  $i$ 's serial cost share as  $\varphi_i^*(C, x) = \int_0^1 \partial_i C(z^{*x}(t)) \frac{dz_i^{*x}}{dt}(t) dt$ , where  $z^{*x} : [0, 1] \rightarrow [0, x]$  is the constrained egalitarian path  $z^{*x}(t) = (tx_n, tx_n, \dots, tx_n) \wedge x$  (and note that  $z_i^{*x}$  is differentiable almost everywhere). Under the Aumann-Shapley method, on the other hand, agent

$i$  pays  $\varphi_i^{AS}(C, x) = \int_0^1 \partial_i C(z^{ASx}(t)) \frac{dz_i^{ASx}}{dt}(t) dt$ , where  $z^{ASx} : [0, 1] \rightarrow [0, x]$  is the diagonal path  $z^{ASx}(t) = tx$ .

We now present our axioms. The first four are adapted from the properties used by Shapley (1953) to characterize the value in the model of cooperative games.

**Additivity.** For all  $C, C' \in \mathcal{C}$  and  $x \in \mathbb{R}_+^N$ ,  $\varphi(C + C', x) = \varphi(C, x) + \varphi(C', x)$ .

As mentioned in the Introduction, our primary motivation for this axiom is tractability. Additive methods can be described fairly explicitly: Friedman and Moulin (1999) and Friedman (2004) offer characterizations of the class of additive methods satisfying the Dummy axiom and Moulin and Vohra (2003) propose a description of the entire class in the discrete version of the cost-sharing model. By comparison, only a few specific nonadditive rules were studied in the literature –see for instance Sprumont (1998)– and no general characterization results are available. Beyond tractability, however, the practical advantages of Additivity should not be underestimated. As many authors have noted, an additive method is easily implementable. When total cost arises from independent production processes, applying the method to the cost function corresponding to each process and adding the resulting cost shares is equivalent to applying it to the aggregated cost function. This guarantees that the proper level of application of the method is not a matter of dispute.

**Weak Dummy.** For all  $C \in \mathcal{C}$ ,  $x \in \mathbb{R}_+^N$ , and  $i \in N$ , if  $x_i = 0$  and  $\partial_i C(z) = 0$  for all  $z \in \mathbb{R}_+^N$ , then  $\varphi_i(C, x) = 0$ .

Following standard terminology, we call agent  $i$  a dummy agent if  $\partial_i C(z) = 0$  for all  $z \in \mathbb{R}_+^N$ . Weak Dummy requires that a dummy agent who demands nothing pays nothing. This is an extremely weak axiom. If the statement that an agent should pay only the fraction of the cost generated by her own demand entails any well defined restriction on  $\varphi$ , this must be one.

**Dummy Independence.** For all  $C \in \mathcal{C}$ ,  $x, x' \in \mathbb{R}_+^N$  and  $i \in N$ , if  $\partial_i C(z) = 0$  for all  $z \in \mathbb{R}_+^N$  and  $x_j = x'_j$  for all  $j \in N \setminus \{i\}$ , then  $\varphi(C, x) = \varphi(C, x')$ .

This axiom says that if total cost is independent of an agent's demand, then cost shares should also be. Together with Weak Dummy, Dummy Independence allows one to essentially ignore all dummy agents. This seems to be a very natural separability condition for a theory aiming at charging agents according to their own impact on total cost. We stress that Dummy Independence is a mild requirement; it is satisfied by the popular cost-sharing methods proposed in the literature, including the Aumann-Shapley method mentioned in the Introduction and the Shapley-Shubik method described in Section 4.

Notice that Weak Dummy and Dummy Independence together imply the familiar Dummy axiom: if  $\partial_i C(z) = 0$  for all  $z \in \mathbb{R}_+^N$ , then  $\varphi_i(C, x) = 0$ . Dummy seems to be unavoidable: since  $C(0) = 0$ , the fraction of the total cost generated by agent  $i$ 's demand is indisputably nil if the cost does not vary with her demand. Given this observation, Dummy Independence may also be defended from a strategic viewpoint. Indeed, a method

satisfying Dummy and violating Dummy Independence would be vulnerable to manipulations by pairs consisting of a dummy and a non-dummy agent: an increase in the dummy agent's demand could reduce her partner's cost share without increasing her own.

Our fourth axiom uses the following notation. If  $\pi$  is a permutation on  $N$ ,  $x \in \mathbb{R}_+^N$  and  $C \in \mathcal{C}$ , we define  $\pi x$  by  $(\pi x)_{\pi(i)} = x_i$  for all  $i \in N$  and we define  $\pi C$  by  $\pi C(\pi z) = C(z)$  for all  $z \in \mathbb{R}_+^N$ . Note that  $\pi C \in \mathcal{C}$ . If  $i, j$  are two distinct agents, we denote by  $\pi^{ij}$  the permutation on  $N$  which exchanges  $i$  and  $j$  :  $\pi^{ij}(i) = j$ ,  $\pi^{ij}(j) = i$  and  $\pi^{ij}(k) = k$  if  $k \in N \setminus \{i, j\}$ .

**Anonymity.** For all  $C \in \mathcal{C}$ ,  $x \in \mathbb{R}_+^N$ , and distinct  $i, j \in N$ , if  $x_i = x_j$ , then  $\varphi_i(C, x) = \varphi_j(\pi^{ij}C, x)$ .

This requirement expresses the familiar idea that the names of the agents should play no role in the computation of the cost shares. This is widely accepted as a very basic notion of fairness and is consistent with condition (c) in the Introduction: characteristics unrelated to the cost function or the demand profile should be ignored. Our formulation is rather weak insofar as it does not impose restrictions on the cost shares across demand profiles: Sprumont (2008), for instance, uses the stronger condition that  $\varphi(\pi C, \pi x) = \pi \varphi(C, x)$  for all  $C \in \mathcal{C}$ ,  $x \in \mathbb{R}_+^N$ , and every permutation  $\pi$  on  $N$ . On the other hand, our axiom does impose restrictions across cost functions; it is stronger than the requirement that agents with equal demands pay the same cost share when the cost function is symmetric in the goods they demand.

Our fifth axiom has no counterpart in Shapley's characterization of the value.

**Group Demand Monotonicity.** For all  $C \in \mathcal{C}$ , all  $x, x' \in \mathbb{R}_+^N$ , and all nonempty  $S \subseteq N$ , if  $x_i < x'_i$  for all  $i \in S$  and  $x_i = x'_i$  for all  $i \in N \setminus S$ , then there exists  $i \in S$  such that  $\varphi_i(C, x) \leq \varphi_i(C, x')$ .

This axiom simply requires that when a group of agents jointly increase their demands, not all of them pay less. It strengthens Moulin's (1995) Demand Monotonicity axiom which only requires that if  $x_i < x'_i$  and  $x_j = x'_j$  for all  $j \in N \setminus \{i\}$ , then  $\varphi_i(C, x) \leq \varphi_i(C, x')$ . As already discussed, Group Demand Monotonicity is in line with the normative principle that cost shares should be positively related to demand sizes. We note that the axiom is also compelling from the strategic viewpoint: in an environment where agents can easily communicate, Group Demand Monotonicity is necessary to prevent manipulations by coordinated artificial inflation of demands.

**Theorem.** *The serial method is the only cost-sharing method satisfying Additivity, Weak Dummy, Dummy Independence, Anonymity and Group Demand Monotonicity.*

### 3. The proof

It is well known and easy to check that the serial method satisfies our first four axioms. To check Group Demand Monotonicity, fix a cost function  $C$ , a group of agents  $S \subseteq N$ ,

and two demand profiles  $x, x'$  such that  $x_i < x'_i$  for all  $i \in S$  and  $x_i = x'_i$  for all  $i \in N \setminus S$ . We claim that the cost share of any agent with minimal demand in  $S$  at  $x$  cannot decrease when the demand profile changes from  $x$  to  $x'$ . Indeed, let  $i_1 \in S$  be such that  $x_{i_1} \leq x_i$  for all  $i \in S$ . Then  $\varphi_{i_1}^*(C, x) = \int_0^{x_{i_1}} \partial_i C((\alpha, \alpha, \dots, \alpha) \wedge x) d\alpha = \int_0^{x_{i_1}} \partial_i C((\alpha, \alpha, \dots, \alpha) \wedge x') d\alpha \leq \int_0^{x'_{i_1}} \partial_i C((\alpha, \alpha, \dots, \alpha) \wedge x') d\alpha = \varphi_{i_1}^*(C, x')$ .

We now turn to the proof that only the serial method satisfies our axioms. The following notation will be used throughout. Vector inequalities are written  $\leq, <, \ll$ . For all  $S \subseteq N$  and  $z \in \mathbb{R}^N$  we denote by  $z_S \in \mathbb{R}^S$  the restriction of  $z$  to  $S$ . If  $z, z' \in \mathbb{R}^N$ , we denote by  $(z_S, z'_{N \setminus S})$  the point in  $\mathbb{R}^N$  whose restrictions to  $S$  and  $N \setminus S$  are  $z_S$  and  $z'_{N \setminus S}$ , respectively. If  $Z \subseteq \mathbb{R}^N$ , we let  $Z_S = \{z_S \in \mathbb{R}^S \mid \exists z_{N \setminus S} \in \mathbb{R}^{N \setminus S} : (z_S, z_{N \setminus S}) \in Z\}$ .

Our proof relies on Friedman and Moulin's (1999) characterization of the cost-sharing methods satisfying Additivity and Dummy.

For any  $x \in \mathbb{R}_+^N$ , denote by  $\mathcal{B}([0, x])$  the set of Borel subsets of  $[0, x]$ . If  $i \in N$ ,  $a \in [0, x]$ , and  $\mu_i^x$  is a Radon measure on  $\mathcal{B}([0, x])$ , define  $m_i^x(a) = \lim_{\varepsilon \rightarrow 0} \frac{1}{\varepsilon} \mu_i^x(\{z \in [0, x] \mid a_i \leq z_i \leq a_i + \varepsilon \text{ and } z_j \geq a_j \text{ for all } j \in N \setminus i\})$ . A *weight system* is a mapping  $\mu$  on  $\mathbb{R}_+^N$ ,  $x \mapsto \mu^x = (\mu_1^x, \dots, \mu_n^x)$ , where each  $\mu_i^x$  is a nonnegative Radon measure on  $\mathcal{B}([0, x])$  satisfying the following two conditions:

$$\mu_i^x(\{z \in [0, x] \mid a_i \leq z_i \leq b_i\}) = b_i - a_i \text{ whenever } 0 \leq a_i \leq b_i \leq x_i, \quad (3.1)$$

$$\sum_{i \in S} m_i^x(a) = 1 \text{ for all } S \subseteq N \text{ and almost all } a \in [0, x] \text{ such that } a_{N \setminus S} = 0, \quad (3.2)$$

where the term ‘‘almost all’’ is understood with respect to the  $|S|$ -dimensional Lebesgue measure on  $[0, (x_S, 0_{N \setminus S})]$ .

**Lemma** (Friedman and Moulin, 1999). *A cost-sharing method  $\varphi$  satisfies Additivity and Dummy if and only if it is generated by a weight system  $\mu$  in the sense that*

$$\varphi_i(C, x) = \int_{[0, x]} \partial_i C d\mu_i^x \text{ for all } i \in N, C \in \mathcal{C}, \text{ and } x \in \mathbb{R}_+^N. \quad (3.3)$$

*This weight system  $\mu$  is unique.*

The role of conditions (3.1), (3.2) is to guarantee that the cost shares defined by (3.3) satisfy budget balance. We refer to  $\mu^x$  as a *weight system at  $x$* . By the *support of  $\mu^x$*  we mean the union of the supports of the measures  $\mu_1^x, \dots, \mu_n^x$ .

We denote by  $\mu^*$  the weight system generating the serial method  $\varphi^*$  and call  $\mu^*$  the *serial weight system*. This system is an example of a *fixed weight system*. In a fixed weight system  $\mu$ , when  $x \leq x'$ , each measure  $\mu_i^x$  is the *projection of  $\mu_i^{x'}$*  onto  $[0, x]$ , namely, the measure  $p_x \mu_i^{x'}$  defined on  $\mathcal{B}([0, x])$  by

$$p_x \mu_i^{x'}(Z) = \mu_i^{x'}(\{z \in [0, x'] \mid z \wedge x \in Z \text{ and } z_i \leq x_i\}). \quad (3.4)$$

For any  $b = (\beta, \beta, \dots, \beta) \in \mathbb{R}_+^N$ , the support of the serial weight system  $\mu^{*b}$  at  $b$  is the set  $\{(\alpha, \alpha, \dots, \alpha) \mid 0 \leq \alpha \leq \beta\}$ , the diagonal of  $[0, b]$ . Using (3.1), it is easy to see that this

property determines  $\mu^{*b}$  uniquely, as noted in the proof of Theorem 2 in Friedman and Moulin (1999). For any  $x \leq b$ , the serial weight system at  $x$  is defined by the projection property  $\mu_i^{*x} = p_x \mu_i^{*b}$  for all  $i \in N$ .

The support of  $\mu^{*x}$  is the constrained egalitarian path to  $x$ . Suppose, without loss of generality, that  $x_1 \leq x_2 \leq \dots \leq x_n$ . For all  $i \in N$ , define the demand profile  $x^i \in \mathbb{R}_+^N$  by  $x_j^i = \min(x_i, x_j)$  for all  $j \in N$ . The support of  $\mu^{*x}$  is

$$S^{*x} = \cup_{i=1}^n co \{x^{i-1}, x^i\}, \quad (3.5)$$

where  $x^0 = 0$  and  $co \{x^{i-1}, x^i\}$  is the line segment joining  $x^{i-1}$  to  $x^i$ . See Figure 1.

**Proof of the Theorem.** Let  $\varphi$  be a cost-sharing method satisfying Additivity, Weak Dummy, Dummy Independence, Anonymity and Group Demand Monotonicity. Since Weak Dummy and Dummy Independence imply Dummy, it follows from Friedman and Moulin's lemma that there exists a weight system  $\mu$  generating  $\varphi$ .

Let  $\beta$  be a positive real number, fix the demand profile  $b = (\beta, \beta, \beta, \dots, \beta)$ , and let  $B = [0, b]$ . Steps 1 to 6 are devoted to showing that  $\mu^b$  coincides with  $\mu^{*b}$ , the serial weight system at  $b$ . Steps 7 and 8 establish that  $\mu^x$  coincides with  $\mu^{*x}$  for all demand profiles  $x \leq b$ .

**Step 1.** We claim that if  $0 < \alpha < \beta$ , and  $a = (\alpha, \alpha, \beta, \dots, \beta)$ , then  $\mu_i^a = p_a \mu_i^b$  for  $i = 3, \dots, n$ .

Fix  $\alpha$  such that  $0 < \alpha < \beta$ , let  $a = (\alpha, \alpha, \beta, \dots, \beta)$  and write  $A = [0, a]$ . We use the following terminology and notation. A set  $E \subseteq \mathbb{R}^N$  is an *interval* (in  $\mathbb{R}^N$ ) if  $E = \times_{i \in N} E_i$ , where each  $E_i$  is an (open, half-open, or closed) interval in  $\mathbb{R}$ . If  $E$  is nonempty, we denote its endpoints by  $e^-(E)$ ,  $e^+(E)$  or simply  $e^-$ ,  $e^+$ . An *open interval* in  $\mathbb{R}^N$  is an interval which is also an open set: if nonempty, it takes the form  $E = \{z \in \mathbb{R}^N \mid e^- \ll z \ll e^+\}$  where  $e^- \ll e^+$ , and we write  $E = ]e^-, e^+[$ . Let  $\mathcal{E}$  and  $\mathcal{E}^o$  denote the set of intervals and the set of open intervals, respectively. The set of intervals which are below the hyperplane  $z_1 = z_2$  is  $\mathcal{E}_< = \{E \in \mathcal{E} \mid z_2 < z_1 \text{ for all } z \in E\}$ ; the set of intervals above it is  $\mathcal{E}_> = \{E \in \mathcal{E} \mid z_2 > z_1 \text{ for all } z \in E\}$ , and the set of intervals whose endpoints are on this hyperplane is  $\mathcal{E}_= = \{E \in \mathcal{E} \mid e_1^-(E) = e_2^-(E) \text{ and } e_1^+(E) = e_2^+(E)\}$ .

**1.1.** We claim that  $\mu_i^a(E \cap A) \geq p_a \mu_i^b(E \cap A)$  for  $i = 3, \dots, n$  and all  $E \in \mathcal{E}^o \cap \mathcal{E}_<$ .

We only give a sketch of the argument and refer the reader to the Appendix for details. Fix  $E \in \mathcal{E}^o \cap \mathcal{E}_<$  and let  $e^-, e^+ \in \mathbb{R}^N$ ,  $e^- \ll e^+$ , be the endpoints of  $E$ . Assume that

$$e_1^+ \leq \alpha \text{ or } e_1^+ > \beta. \quad (3.6)$$

This assumption entails no loss of generality. (If  $\alpha < e_1^+ \leq \beta$ , choose  $e_1^{++} > \beta$  and consider the open interval  $E^+ = ]e^-, (e_1^{++}, e_{N \setminus 1}^+)[$ . Apply the argument below to  $E^+$  rather than  $E$  to obtain  $\mu_i^a(E^+ \cap A) \geq p_a \mu_i^b(E^+ \cap A)$  for  $i = 3, \dots, n$ . Since  $E^+ \cap A = E \cap A$ , our claim follows.) Assumption (3.6) guarantees that

$$p_a \mu_i^b(E \cap A) = \mu_i^b(E \cap B) \text{ for } i = 3, \dots, n. \quad (3.7)$$

Suppose now, by way of contradiction, that, say,

$$\mu_3^a(E \cap A) < p_a \mu_3^b(E \cap A). \quad (3.8)$$

Assume also that  $0 \leq e_3^-$  and  $e_3^+ \leq \beta$ : this too is without loss of generality because  $\mu_3^a(\{z \in A \mid z_3 = 0\}) = \mu_3^a(\{z \in A \mid z_3 = \beta\}) = p_a \mu_3^b(\{z \in A \mid z_3 = 0\}) = p_a \mu_3^b(\{z \in A \mid z_3 = \beta\}) = 0$  by (3.1). For any set  $Z \subseteq \mathbb{R}^N$ , let  $\pi^{12}Z = \{\pi^{12}z \mid z \in Z\}$ , where we recall that  $\pi^{12}$  is the permutation exchanging agents 1 and 2, and let  $Z_* = Z \cup \pi^{12}Z$ : this is the smallest superset of  $Z$  that is symmetric with respect to the hyperplane  $z_1 = z_2$ .

Suppose we could construct a cost function  $C$  such that (a)  $C(a) = C(b)$ , (b)  $C(z)$  is independent of  $z_4, \dots, z_n$ , and (c)  $\partial_3 C$  is a positive constant  $k$  on  $E \cap \mathbb{R}_+^N$  and zero elsewhere. Define the function  $C_*$  on  $\mathbb{R}_+^N$  by  $C_*(z) = C(z)$  if  $z_1 \geq z_2$  and  $C_*(z) = \pi^{12}C(z)$  otherwise.

By Anonymity  $\varphi_1(C, a) + \varphi_2(C, a) = \varphi_2(\pi^{12}C, a) + \varphi_1(\pi^{12}C, a)$  and by Dummy  $\varphi_i(C, a) = 0 = \varphi_i(\pi^{12}C, a)$  for  $i = 4, \dots, n$ . Since  $C(a) = \pi^{12}C(a)$ , budget balance implies  $\varphi_3(C, a) = \varphi_3(\pi^{12}C, a)$ . Since  $\varphi_3(C, a) = \int_A \partial_3 C d\mu_3^a = k\mu_3^a(E \cap A)$  and  $\varphi_3(\pi^{12}C, a) = \int_A \partial_3 \pi^{12}C d\mu_3^a = k\mu_3^a(\pi^{12}(E \cap A))$ , we obtain  $\mu_3^a(E \cap A) = \mu_3^a(\pi^{12}(E \cap A))$  and therefore  $\mu_3^a((E \cap A)_*) = 2\mu_3^a(E \cap A)$ .

Likewise, since  $\varphi_3(C, b) = k\mu_3^b(E \cap B) = kp_a \mu_3^b(E \cap A)$  (by (3.7)) and  $\varphi_3(\pi^{12}C, b) = kp_a \mu_3^b(\pi^{12}(E \cap A))$ , a similar argument yields  $p_a \mu_3^b((E \cap A)_*) = 2p_a \mu_3^b(E \cap A)$ . Therefore inequality (3.8) implies  $\mu_3^a((E \cap A)_*) < p_a \mu_3^b((E \cap A)_*)$ .

Now, since  $\varphi_3(C_*, a) = k\mu_3^a((E \cap A)_*)$  and  $\varphi_3(C_*, b) = kp_a \mu_3^b((E \cap A)_*)$ , it follows that  $\varphi_3(C_*, a) < \varphi_3(C_*, b)$ . By Dummy,  $\varphi_i(C_*, a) = 0 = \varphi_i(C_*, b)$  for  $i = 4, \dots, n$ . Since  $C_*(a) = C_*(b)$ , budget balance implies  $\varphi_1(C_*, a) + \varphi_2(C_*, a) > \varphi_1(C_*, b) + \varphi_2(C_*, b)$ . By Anonymity,  $\varphi_i(C_*, a) > \varphi_i(C_*, b)$  for  $i = 1, 2$ , contradicting Group Demand Monotonicity.

An example of a nondecreasing function  $C$  satisfying properties (a), (b) and (c) above is the following. For all  $z \in \mathbb{R}^N$  and  $i \in N$ , define  $z'_i = \frac{z_i - e_i^-}{e_i^+ - e_i^-}$ . Let  $z''_3 = \text{med}(0, z'_3, 1)$ , the median of the three numbers 0,  $z'_3$ , 1, and define  $C : \mathbb{R}_+^N \rightarrow [0, 1]$  by

$$C(z) = \begin{cases} z''_3 & \text{if } (z_1, z_2) \in E_{\{1,2\}}, \\ 0 & \text{if } (z_1, z_2) \notin E_{\{1,2\}} \text{ and } z'_1 + z'_2 < 1, \\ \frac{1}{2} & \text{if } (z_1, z_2) \notin E_{\{1,2\}} \text{ and } z'_1 + z'_2 = 1, \\ 1 & \text{if } (z_1, z_2) \notin E_{\{1,2\}} \text{ and } z'_1 + z'_2 > 1, \end{cases} \quad (3.9)$$

where we recall that  $E_{\{1,2\}} = \{(z_1, z_2) \mid \exists z_3, \dots, z_n : (z_1, z_2, z_3, \dots, z_n) \in E\}$ . See Figure 2 for an illustration. The only difficulty is that  $C$  is not a cost function: it is not continuously differentiable or indeed even continuous. The formal proof in the Appendix involves approximating  $C$  by a sequence of cost functions.

**1.2.** We claim that  $\mu_i^a(E \cap A) \geq p_a \mu_i^b(E \cap A)$  for  $i = 3, \dots, n$  and all  $E \in \mathcal{E}_<$ .

Let  $E \in \mathcal{E}_<$  be an interval with endpoints  $e^-, e^+$ . Partition  $N$  into  $N_{<, <}$ ,  $N_{<, \leq}$ ,  $N_{\leq, <}$ ,  $N_{\leq, \leq}$  so that  $E = \{z \in \mathbb{R}^N \mid e_i^- < z_i < e_i^+ \text{ if } i \in N_{<, <}, e_i^- < z_i \leq e_i^+ \text{ if } i \in N_{<, \leq}, e_i^- \leq z_i < e_i^+ \text{ if } i \in N_{\leq, <}, \text{ and } e_i^- \leq z_i \leq e_i^+ \text{ if } i \in N_{\leq, \leq}\}$ . For  $m = 1, 2, \dots$ , define  $E_m = \{z \in \mathbb{R}^N \mid e_i^- < z_i < e_i^+ \text{ if } i \in N_{<, <}, e_i^- < z_i < e_i^+ + \frac{1}{m} \text{ if } i \in N_{<, \leq}, e_i^- - \frac{1}{m} < z_i < e_i^+ \text{ if } i \in N_{\leq, <}, \text{ and } e_i^- - \frac{1}{m} < z_i < e_i^+ \text{ if } i \in N_{\leq, \leq}\}$ .



$i \in N_{\leq, <}$ , and  $e_i^- - \frac{1}{m} < z_i < e_i^+ + \frac{1}{m}$  if  $i \in N_{\leq, \leq}$ . By definition,  $E_{m+1} \subseteq E_m$  for  $m = 1, 2, \dots$  and  $\bigcap_{m=1}^{\infty} E_m = E$ . It follows that for all  $i = 3, \dots, n$ ,  $\mu_i^a(E \cap A) = \lim_{m \rightarrow \infty} \mu_i^a(E_m \cap A)$  and  $p_a \mu_i^b(E \cap A) = \lim_{m \rightarrow \infty} p_a \mu_i^b(E_m \cap A)$ . By Step 1.1,  $\mu_i^a(E_m \cap A) \geq p_a \mu_i^b(E_m \cap A)$  for  $m = 1, 2, \dots$  and  $i = 3, \dots, n$ . The claim follows.

**1.3.** We claim that  $\mu_i^a(E \cap A) \geq p_a \mu_i^b(E \cap A)$  for  $i = 3, \dots, n$  and all  $E \in \mathcal{E}$ .

*Mutatis mutandis*, the proof that  $\mu_i^a(E \cap A) \geq p_a \mu_i^b(E \cap A)$  for  $i = 3, \dots, n$  and all  $E \in \mathcal{E}_{>}$  is identical to the argument in Steps 1.1 and 1.2. The proof that  $\mu_i^a(E \cap A) \geq p_a \mu_i^b(E \cap A)$  for  $i = 3, \dots, n$  and all  $E \in \mathcal{E}_=$  is also similar. When  $E \in \mathcal{E}_=$  the function  $C$  in (3.9) is symmetric with respect to  $z_1, z_2$  and  $C_*$  coincides with  $C$ . Assumption (3.6) guarantees that  $C(a) = C(b)$ . The only change required in the formal proof in the Appendix is that the functions  $\tilde{C}^m$  satisfying (5.2) to (5.5) must now be symmetric with respect to  $z_1, z_2$ . This causes no difficulty since  $E$  itself is symmetric with respect to  $z_1, z_2$ . To conclude the proof of Step 1.3, it suffices to note that every interval in  $\mathcal{E}$  can be written as a disjoint union of intervals in  $\mathcal{E}_{<}$ ,  $\mathcal{E}_{>}$  and  $\mathcal{E}_=$ .

**1.4.** We claim that  $\mu_i^a(E \cap A) = p_a \mu_i^b(E \cap A)$  for  $i = 3, \dots, n$  and all  $E \in \mathcal{E}$ .

Let  $E \in \mathcal{E}$  be an interval with endpoints  $e^-, e^+$ , fix  $i \in \{3, \dots, n\}$  and assume without loss of generality that  $0 \leq e_i^-$  and  $e_i^+ \leq \beta$ . Let  $G = \{z \in \mathbb{R}^N \mid e_i^- \leq z_i \leq e_i^+\}$ . Applying (3.1) to  $\mu_i^a$  and  $p_a \mu_i^b$ ,

$$\mu_i^a(G \cap A) = e_i^+ - e_i^- = p_a \mu_i^b(G \cap A). \quad (3.10)$$

Partition  $G \setminus E$  into the eight disjoint intervals  $G_{<, <} = G_1$ ,  $G_{=, <} = G_2$ ,  $G_{>, <} = G_3$ ,  $G_{<, =} = G_4$ ,  $G_{>, =} = G_5$ ,  $G_{<, >} = G_6$ ,  $G_{=, >} = G_7$  and  $G_{>, >} = G_8$ , where  $G_{<, <} = \{z \in G \mid z_1 < z'_1 \text{ and } z_2 < z'_2 \text{ for all } z' \in E\}$ ,  $G_{=, <} = \{z \in G \mid z_1 = z'_1 \text{ for some } z' \in E \text{ and } z_2 < z'_2 \text{ for all } z' \in E\}$ ,  $G_{>, <} = \{z \in G \mid z_1 > z'_1 \text{ and } z_2 < z'_2 \text{ for all } z' \in E\}$ , and so on.

By (3.10),  $\mu_i^a(E \cap A) = (e_i^+ - e_i^-) - \sum_{k=1}^8 \mu_i^a(G_k \cap A)$  and  $p_a \mu_i^b(E \cap A) = (e_i^+ - e_i^-) - \sum_{k=1}^8 p_a \mu_i^b(G_k \cap A)$ . By Step 1.3,  $\mu_i^a(G_k \cap A) \geq p_a \mu_i^b(G_k \cap A)$  for  $k = 1, \dots, 8$ . Hence  $\mu_i^a(E \cap A) \leq p_a \mu_i^b(E \cap A)$ . Since the opposite weak inequality holds by Step 1.3, we are done.

**1.5.** We claim that  $\mu_i^a(Z) = p_a \mu_i^b(Z)$  for  $i = 3, \dots, n$  and all  $Z \in \mathcal{B}(A)$ .

Because every open set in  $\mathbb{R}^N$  is the union of a countable collection of (open) intervals, Step 1.5 follows from Step 1.4, the definition of the Borel sets, and the countable additivity of the measures  $\mu_i^a$  and  $p_a \mu_i^b$ .

**Step 2.** For any real number  $\alpha$  such that  $0 < \alpha < \beta$ , partition  $B$  into  $B^0(\alpha) = \{z \in B \mid z_1, z_2 \leq \alpha\}$ ,  $B^1(\alpha) = \{z \in B \mid z_2 < \alpha < z_1\}$ ,  $B^2(\alpha) = \{z \in B \mid z_1 < \alpha < z_2\}$ , and  $B^3(\alpha) = \{z \in B \mid (\alpha, \alpha) < (z_1, z_2)\}$ . Recall that  $(\alpha, \alpha) < (z_1, z_2)$  means that  $\alpha \leq z_1$ ,  $\alpha \leq z_2$ , and at least one of these inequalities is strict. We claim that

$$\mu_i^b(B^1(\alpha) \cup B^2(\alpha)) = 0 \text{ for } i = 3, \dots, n. \quad (3.11)$$

The proof works by constructing a particular cost function  $C$  and applying Anonymity and Group Demand Monotonicity to the problems  $(C, a)$ ,  $(C, b)$ . Although the construction

of  $C$  is in essence rather simple, the requirement that it be continuously differentiable introduces unavoidable minor complications. We begin by defining  $C$  on the set  $\overline{B} = \{z \in B \mid z_i = \beta \text{ for } i = 3, \dots, n\}$ . If  $z = (z_1, z_2, \beta, \dots, \beta) \in \overline{B}$ , we abbreviate notation by writing  $z = (z_1, z_2)$ .

Let  $s : \mathbb{R} \rightarrow [0, 1]$  be a ‘‘smoothing function’’, namely, a nondecreasing, continuously differentiable function such that  $s(0) = 0$ ,  $s(1) = 1$ , and  $s'(0) = s'(1) = 0$ . Define  $h : \overline{B} \rightarrow [0, 1]$  by

$$h(z) = \begin{cases} s\left(\frac{2}{1 + \frac{\alpha - z_2}{\alpha - z_1}}\right) & \text{if } 0 \leq z_2 \leq z_1 < \alpha, \\ s\left(\frac{2}{1 + \frac{\alpha - z_1}{\alpha - z_2}}\right) & \text{if } 0 \leq z_1 < z_2 < \alpha, \\ 0 & \text{otherwise.} \end{cases}$$

The level sets of this function are shown in Figure 3. Observe that  $h(\gamma, \gamma) = 1$  whenever  $0 \leq \gamma < \alpha$ . The function  $h$  is continuously differentiable everywhere but at  $(\alpha, \alpha)$ , where it is discontinuous.

Define the functions  $C_1, C_2 : \overline{B} \rightarrow [0, 1]$  by

$$\begin{aligned} C_1(z) &= s\left(1 - \left(\frac{\beta - z_1}{\beta - \alpha} - h(z)\right) \left(\frac{\alpha - z_2}{\alpha}\right)\right), \\ C_2(z) &= s\left(1 - \left(\frac{\alpha - z_1}{\alpha}\right) \left(\frac{\beta - z_2}{\beta - \alpha} - h(z)\right)\right). \end{aligned}$$

Observe that  $C_1(z) = C_2(z) = 1$  if  $z \geq (\alpha, \alpha)$  and  $C_1(\gamma, \gamma) = C_2(\gamma, \gamma)$  whenever  $0 \leq \gamma < \alpha$ . The functions  $C_1, C_2$  are continuously differentiable at every point, including  $(\alpha, \alpha)$  where  $\partial_i C_j(\alpha, \alpha) = 0$  for  $i, j \in \{1, 2\}$ . Moreover, one checks that  $\partial_i C_1(\gamma, \gamma) = \partial_i C_2(\gamma, \gamma)$  for  $0 \leq \gamma < \alpha$  and  $i \in \{1, 2\}$ .

Partition the set  $\overline{B}$  into  $\overline{B}^{01}(\alpha) = \{z \in \overline{B} \mid z_2 < z_1 \leq \alpha\}$ ,  $\overline{B}^{02}(\alpha) = \{z \in \overline{B} \mid z_1 \leq z_2 \leq \alpha\}$ ,  $\overline{B}^1(\alpha) = \{z \in \overline{B} \mid z_2 < \alpha < z_1\}$ ,  $\overline{B}^2(\alpha) = \{z \in \overline{B} \mid z_1 < \alpha < z_2\}$ , and  $\overline{B}^3(\alpha) = \{z \in \overline{B} \mid (\alpha, \alpha) < (z_1, z_2)\}$ . Define  $C : \overline{B} \rightarrow [0, 1]$  by

$$C(z) = \begin{cases} C_1(z) & \text{if } z \in \overline{B}^{01}(\alpha) \cup \overline{B}^1(\alpha), \\ C_2(z) & \text{if } z \in \overline{B}^{02}(\alpha) \cup \overline{B}^2(\alpha), \\ 1 & \text{if } z \in \overline{B}^3(\alpha). \end{cases}$$

Thanks to the properties of  $C_1, C_2$  discussed above,  $C$  is continuously differentiable and one checks that it is nondecreasing. The level sets of  $C$  are drawn in Figure 4. Note that  $C(a) = C(b) = 1$ .

Finally, with a slight abuse of notation, we extend  $C$  to  $\mathbb{R}_+^N$  by letting

$$C(z) = \frac{\sum_{i=3}^n z_i}{(n-2)\beta} C(\min(z_1, \beta), \min(z_2, \beta), \beta, \dots, \beta)$$

for all  $z \in \mathbb{R}_+^N$ . This function belongs to  $\mathcal{C}$ .

Suppose now that (3.11) is false: say,  $\mu_3^b(B^1(\alpha) \cup B^2(\alpha)) > 0$ . Let  $a = (\alpha, \alpha, \beta, \dots, \beta)$ ,  $A = [0, a]$ , and define the function  $\partial_3^a C : \mathbb{R}_+^N \rightarrow \mathbb{R}_+$  by  $\partial_3^a C(z) = \partial_3 C(z \wedge a)$ . By Step 1, the measure  $\mu_3^a$  is obtained by projection of  $\mu_3^b$  onto  $A$ . It then follows from the definition of the Lebesgue integral that

$$\int_A \partial_3 C d\mu_3^a = \int_B \partial_3^a C d\mu_3^b.$$

From the definition of  $C$ , we have

$$\begin{aligned} \partial_3^a C(z) &= \partial_3 C(z) \text{ for all } z \in B^0(\alpha) \cup B^3(\alpha), \\ \partial_3^a C(z) &< \partial_3 C(z) \text{ for all } z \in B^1(\alpha) \cup B^2(\alpha). \end{aligned}$$

For instance, if  $z \in B^1(\alpha)$ , then  $\partial_3^a C(z) = \partial_3 C(\alpha, z_2, z_3, \dots, z_n) = \frac{1}{(n-2)\beta} C(\alpha, z_2, \beta, \dots, \beta) < \frac{1}{(n-2)\beta} C(z_1, z_2, \beta, \dots, \beta) = \partial_3 C(z)$ .

Therefore

$$\begin{aligned} \varphi_3(C, b) - \varphi_3(C, a) &= \int_B \partial_3 C d\mu_3^b - \int_A \partial_3 C d\mu_3^a \\ &= \int_B (\partial_3 C - \partial_3^a C) d\mu_3^b \\ &= \int_{B^1(\alpha) \cup B^2(\alpha)} (\partial_3 C - \partial_3^a C) d\mu_3^b \\ &> 0, \end{aligned}$$

that is,  $\varphi_3(C, a) < \varphi_3(C, b)$ . Since  $C$  is symmetric in  $z_3, \dots, z_n$  and  $a_3 = \dots = a_n = \beta$  and  $b_3 = \dots = b_n = \beta$ , Anonymity implies  $\varphi_3(C, a) = \dots = \varphi_n(C, a)$  and  $\varphi_3(C, b) = \dots = \varphi_n(C, b)$ . Therefore  $\varphi_i(C, a) < \varphi_i(C, b)$  for  $i = 3, \dots, n$ . Since  $C(a) = C(b)$ , budget balance implies  $\varphi_1(C, a) + \varphi_2(C, a) > \varphi_1(C, b) + \varphi_2(C, b)$ . But since  $C$  is symmetric in  $z_1, z_2$  and  $a_1 = a_2 = \alpha$  and  $b_1 = b_2 = \beta$ , Anonymity also forces  $\varphi_1(C, a) = \varphi_2(C, a)$  and  $\varphi_1(C, b) = \varphi_2(C, b)$ . Hence,  $\varphi_1(C, a) > \varphi_1(C, b)$  and  $\varphi_2(C, a) > \varphi_2(C, b)$ , contradicting Group Demand Monotonicity.

**Step 3.** Define  $D^{12} = \{z \in B \mid z_1 = z_2\}$ . We claim that

$$\mu_i^b(D^{12}) = \mu_i^b(B) \text{ for } i = 3, \dots, n. \quad (3.12)$$

For any real number  $\alpha$  such that  $0 < \alpha < \beta$ , let  $B^{12}(\alpha) = B^1(\alpha) \cup B^2(\alpha)$  and  $D^{12}(\alpha) = B \setminus B^{12}(\alpha)$ . For  $r = 1, 2, \dots$ , let  $B_r^{12} = \cup_{k=1}^{r-1} B^{12}(\frac{k\beta}{r})$  and  $D_r^{12} = B \setminus B_r^{12}$ . See Figure 5 for an illustration when  $n = 3$ . We get

$$\begin{aligned} \mu_i^b(D_r^{12}) &= \mu_i^b(B) - \mu_i^b(B_r^{12}) \\ &= \mu_i^b(B) - \mu_i^b(\cup_{k=1}^{r-1} B^{12}(\frac{k\beta}{r})) \\ &= \mu_i^b(B) \end{aligned}$$

for  $i = 3, \dots, n$ , where the last equality holds because (3.11) guarantees that  $\mu_i^b(B^{12}(\frac{k\beta}{r})) = 0$  for  $k = 1, \dots, r-1$  and  $i = 3, \dots, n$ . Since  $D_r^{12} \supseteq D_{r+1}^{12}$  for  $r = 1, 2, \dots$  and  $D^{12} = \bigcap_{r=1}^{\infty} D_r^{12}$ , we obtain

$$\begin{aligned}\mu_i^b(D^{12}) &= \mu_i^b(\bigcap_{r=1}^{\infty} D_r^{12}) \\ &= \lim_{r \rightarrow \infty} \mu_i^b(D_r^{12}) \\ &= \mu_i^b(B)\end{aligned}$$

for  $i = 3, \dots, n$ .

**Step 4.** For all  $S \subseteq N \setminus 3$  such that  $|S| \geq 2$ , let  $D^S = \{z \in B \mid z_i = z_j \text{ for all } i, j \in S\}$ . We claim that

$$\mu_3^b(D^{N \setminus 3}) = \mu_3^b(B). \quad (3.13)$$

From Step 3,  $\mu_3^b(D^{\{1,2\}}) = \mu_3^b(B)$ . Since the choice of agents 1 and 2 in Steps 1, 2 and 3 was arbitrary, this conclusion generalizes to

$$\mu_3^b(D^S) = \mu_3^b(B) \text{ for all } S \subseteq N \setminus 3 \text{ such that } |S| = 2. \quad (3.14)$$

For all  $S \subseteq N \setminus 3$  such that  $|S| \geq 2$ , define  $\widehat{D}^S = \{z \in D^S \mid z_i \neq z_k \text{ for all } i \in S \text{ and all } k \in (N \setminus 3) \setminus S\}$ . Statement (3.14) implies

$$\mu_3^b(\widehat{D}^S) = 0 \text{ for all } S \subseteq N \setminus 3 \text{ such that } 2 \leq |S| \leq n-2. \quad (3.15)$$

To see why, suppose there exists  $S \subseteq N \setminus 3$  such that  $2 \leq |S| \leq n-2$  and  $\mu_3^b(\widehat{D}^S) > 0$ . Because  $1 \leq |S| \leq n-2$ , there exist  $i \in S$  and  $k \in (N \setminus 3) \setminus S$  such that  $\widehat{D}^S \subseteq \{z \in B \mid z_i \neq z_k\} = B \setminus D^{\{i,k\}}$ . But then  $\mu_3^b(B \setminus D^{\{i,k\}}) \geq \mu_3^b(\widehat{D}^S) > 0$ , hence  $\mu_3^b(D^{\{i,k\}}) < \mu_3^b(B)$ , contradicting (3.14).

Notice that  $\bigcup_{S \subseteq N \setminus 3: |S| \geq 2} D^S = \{z \in B \mid \exists i, j \in N \setminus 3 : i \neq j \text{ and } z_i = z_j\}$ . Since for all  $S \subseteq N \setminus 3$  such that  $|S| \geq 2$ ,  $D^S = \bigcup_{T \subseteq N \setminus 3: T \supseteq S} \widehat{D}^T$ , we have

$$\bigcup_{S \subseteq N \setminus 3: |S| \geq 2} D^S = \bigcup_{S \subseteq N \setminus 3: |S| \geq 2} \widehat{D}^S.$$

Since  $D^{N \setminus 3} = \widehat{D}^{N \setminus 3} = \{z \in B \mid z_i = z_j \text{ for all } i, j \in N \setminus 3\}$ , it follows that

$$D^{N \setminus 3} = \left( \bigcup_{S \subseteq N \setminus 3: |S| \geq 2} D^S \right) \setminus \left( \bigcup_{\substack{S \subseteq N \setminus 3: \\ 2 \leq |S| \leq n-2}} \widehat{D}^S \right).$$

Using (3.14) and (3.15), it follows that  $\mu_3^b(D^{N \setminus 3}) \geq \mu_3^b(B)$ . This inequality must be an equality since  $D^{N \setminus 3} \subseteq B$ .

**Step 5.** We interrupt the course of the proof to establish a general property of the weight system  $\mu$  that will be used in Step 6. This property does not depend on the assumption that  $\varphi$  satisfies Anonymity and Group Demand Monotonicity; it is implied by (3.1), (3.2), and (3.3). For any real number  $\alpha$  such that  $0 < \alpha < \beta$ , define  $E_{3+}(\alpha) = \{z \in B \mid z_3 \geq \alpha > z_j \text{ for all } j \in N \setminus 3\}$  and  $E_{3-}(\alpha) = \{z \in B \mid z_3 \leq \alpha < z_j \text{ for all } j \in N \setminus 3\}$ . See Figure 6. We claim that

$$\text{if } \mu_i^b(E_{3+}(\alpha)) = 0 \text{ for all } i \in N \setminus 3, \text{ then } \mu_3^b(E_{3+}(\alpha)) = 0, \quad (3.16)$$

and

$$\text{if } \mu_i^b(E_{3-}(\alpha)) = 0 \text{ for all } i \in N \setminus 3, \text{ then } \mu_3^b(E_{3-}(\alpha)) = 0. \quad (3.17)$$

We prove (3.16) and leave the similar proof of (3.17) to the reader. If  $i \in N$  and  $P$  is a property that points of  $B$  may have, we abbreviate notation by writing  $\mu_i^b(P)$  instead of  $\mu_i^b(\{z \in B \mid z \text{ satisfies property } P\})$ . For all  $t \in B$ ,  $i \in N$ ,  $S \subseteq N \setminus i$ , and  $\varepsilon > 0$  small enough, we define

$$m_i^S(t) = \lim_{\varepsilon \rightarrow 0} \frac{1}{\varepsilon} \mu_i^b(t_i \leq z_i \leq t_i + \varepsilon, z_j < t_j \text{ if } j \in S, \text{ and } z_j \geq t_j \text{ if } j \in (N \setminus i) \setminus S)$$

In particular,  $m_i^\emptyset(t) = m_i^b(t)$ , as defined just before condition (3.1).

**5.1.** We claim that if  $0 < \alpha' < \alpha$ , then

$$\mu_3^b(z_i < \alpha' \text{ for } i \in N \setminus 3 \text{ and } z_3 \geq \alpha) = \int_\alpha^\beta m_3^{N \setminus 3}(\alpha', \alpha', z_3, \alpha', \dots, \alpha') dz_3. \quad (3.18)$$

Defining  $M(t_3) = \mu_3^b(z_i < \alpha' \text{ for } i \in N \setminus 3 \text{ and } z_3 \geq t_3)$ , we have  $M'(t_3) = \lim_{\varepsilon \rightarrow 0} \frac{1}{\varepsilon} (M(t_3 + \varepsilon) - M(t_3)) = \lim_{\varepsilon \rightarrow 0} \frac{1}{\varepsilon} (\mu_3^b(z_i < \alpha' \text{ for } i \in N \setminus 3 \text{ and } z_3 \geq t_3 + \varepsilon) - \mu_3^b(z_i < \alpha' \text{ for } i \in N \setminus 3 \text{ and } z_3 \geq t_3)) = -\lim_{\varepsilon \rightarrow 0} \frac{1}{\varepsilon} \mu_3^b(z_i < \alpha' \text{ for } i \in N \setminus 3 \text{ and } t_3 \leq z_3 < t_3 + \varepsilon) = -m_3^{N \setminus 3}(\alpha', \alpha', t_3, \alpha', \dots, \alpha')$ , where the last equality uses property (3.1).

Hence  $\int_\alpha^\beta m_3^{N \setminus 3}(\alpha', \alpha', t_3, \alpha', \dots, \alpha') dt_3 = -\int_\alpha^\beta M'(t_3) dt_3 = M(\alpha) - M(\beta) = \mu_3^b(z_i < \alpha' \text{ for } i \in N \setminus 3 \text{ and } z_3 \geq \alpha) - \mu_3^b(z_i < \alpha' \text{ for } i \in N \setminus 3 \text{ and } z_3 \geq \beta) = \mu_3^b(z_i < \alpha' \text{ for } i \in N \setminus 3 \text{ and } z_3 \geq \alpha)$ .

**5.2.** Next we claim that if  $0 < \alpha' < \alpha$ , then

$$m_3^{N \setminus 3}(\alpha', \alpha', z_3, \alpha', \dots, \alpha') = \sum_{i \in N \setminus 3} m_i^{(N \setminus 3) \setminus i}(\alpha', \alpha', z_3, \alpha', \dots, \alpha') \text{ for almost all } z_3 \in [\alpha, \beta]. \quad (3.19)$$

To see why this is true, fix  $z_3 \in [\alpha, \beta]$  and write  $a' = (\alpha', \alpha', z_3, \alpha', \dots, \alpha')$ . For any set  $S$  such that  $3 \in S \subseteq N$ , applying property (3.2) gives  $\sum_{i \in S} m_i^b(a'_S, 0_{N \setminus S}) = 1$  almost surely whenever  $3 \in S \subseteq N$ . By definition of  $m_i^T(a')$ , we have  $m_i^b(a'_S, 0_{N \setminus S}) = m_i^\emptyset(a'_S, 0_{N \setminus S}) = \sum_{T: \emptyset \subseteq T \subseteq N \setminus S} m_i^T(a')$  for all  $i \in S$ . Therefore,

$$\sum_{i \in S} \sum_{T: \emptyset \subseteq T \subseteq N \setminus S} m_i^T(a') = 1$$

almost surely whenever  $3 \in S \subseteq N$ . Adding up these conditions pre-multiplied by alternating positive and negative unit coefficients,

$$\sum_{S:3 \in S \subseteq N} (-1)^{|S|-1} \left( \sum_{i \in S} \sum_{T: \emptyset \subseteq T \subseteq N \setminus S} m_i^T(a') \right) = 0$$

almost surely. Cancelling terms in the left-hand side of this equation, we obtain

$$m_3^{N \setminus 3}(a') - \sum_{i \in N \setminus 3} m_i^{(N \setminus 3) \setminus i}(a') = 0$$

almost surely, as claimed.

**5.3.** Assume now that  $\mu_i^b(E_{3+}(\alpha)) = 0$  for all  $i \in N \setminus 3$ . Combining (3.18) and (3.19),

$$\mu_3^b(z_i < \alpha' \text{ for } i \in N \setminus 3 \text{ and } z_3 \geq \alpha) = \int_{\alpha}^{\beta} \sum_{i \in N \setminus 3} m_i^{(N \setminus 3) \setminus i}(\alpha', \alpha', z_3, \alpha', \dots, \alpha') dz_3$$

whenever  $0 < \alpha' < \alpha$ . But if  $i \in N \setminus 3$  and  $\alpha \leq t_3 \leq \beta$ , then  $m_i^{(N \setminus 3) \setminus i}(\alpha', \alpha', t_3, \alpha', \dots, \alpha') = \lim_{\varepsilon \rightarrow 0} \frac{1}{\varepsilon} \mu_i^b(\alpha' \leq z_i \leq \alpha' + \varepsilon, z_j < \alpha' \text{ for } j \in (N \setminus 3) \setminus i, \text{ and } z_3 \geq t_3) = 0$  because  $\mu_i^b(E_{3+}(\alpha)) = 0$  and  $\{z \in B \mid \alpha' \leq z_i \leq \alpha' + \varepsilon, z_j < \alpha' \text{ for } j \in (N \setminus 3) \setminus i, \text{ and } z_3 \geq t_3\} \subseteq E_{3+}(\alpha)$  when  $\varepsilon$  is sufficiently small. Therefore

$$\mu_3^b(z_i < \alpha' \text{ for } i \in N \setminus 3 \text{ and } z_3 \geq \alpha) = 0 \tag{3.20}$$

whenever  $0 < \alpha' < \alpha$ .

A standard limit argument completes Step 5. Writing  $E_{3+}^k(\alpha) = \{z \in B \mid z_i < \alpha - \frac{1}{k} \text{ for } i \in N \setminus 3 \text{ and } z_3 \geq \alpha\}$  for  $k = 1, 2, \dots$ , we have  $\mu_3^b(E_{3+}^k(\alpha)) = 0$  from (3.20). Since  $E_{3+}^k(\alpha) \subseteq E_{3+}^{k+1}(\alpha)$  for all  $k$  and  $\bigcup_{k=1}^{\infty} E_{3+}^k = E_{3+}(\alpha)$ , we get  $\mu_3^b(E_{3+}(\alpha)) = \lim_{k \rightarrow \infty} \mu_3^b(E_{3+}^k(\alpha)) = 0$ .

**Step 6.** We claim that

$$\mu^b = \mu^{*b}. \tag{3.21}$$

Let  $D = \{z \in B \mid z_i = z_j \text{ for all } i, j \in N\}$ . We first show that

$$\mu_3^b(D) = \mu_3^b(B), \tag{3.22}$$

that is, the support of  $\mu_3^b$  is included in the diagonal of  $B$ .

Partition  $D^{N \setminus 3}$  into  $D = \{z \in D^{N \setminus 3} \mid z_3 = z_i \text{ for all } i \in N \setminus 3\}$ ,  $D_+^{N \setminus 3} = \{z \in D^{N \setminus 3} \mid z_3 > z_i \text{ for all } i \in N \setminus 3\}$ , and  $D_-^{N \setminus 3} = \{z \in D^{N \setminus 3} \mid z_3 < z_i \text{ for all } i \in N \setminus 3\}$ . Suppose, contrary to our claim, that  $\mu_3^b(D) < \mu_3^b(B)$ . Then  $\mu_3^b(D_+^{N \setminus 3}) > 0$  or  $\mu_3^b(D_-^{N \setminus 3}) > 0$ . We consider the case where  $\mu_3^b(D_+^{N \setminus 3}) > 0$  and derive a contradiction. If  $\mu_3^b(D_-^{N \setminus 3}) > 0$ , a completely similar argument (using (3.17) instead of (3.16)) leads to a similar contradiction.

For  $k = 1, 2, \dots$ , define  $D_+^{N \setminus 3}(k) = \{z \in B \mid z_3 - \frac{1}{k} \geq z_i = z_j \text{ for all } i, j \in N \setminus 3\}$ . See Figure 7. Since  $D_+^{N \setminus 3}(k) \subseteq D_+^{N \setminus 3}(k+1)$  for all  $k$  and  $\bigcup_{k=1}^{\infty} D_+^{N \setminus 3}(k) = D_+^{N \setminus 3}$ , we have  $\mu_3^b(D_+^{N \setminus 3}) = \lim_{k \rightarrow \infty} \mu_3^b(D_+^{N \setminus 3}(k))$ . Therefore there is some  $k$  such that

$$\mu_3^b(D_+^{N \setminus 3}(k)) > 0. \quad (3.23)$$

Let  $\Gamma$  be a finite subset of  $[0, \beta]$  such that

$$D_+^{N \setminus 3}(k) \subseteq \bigcup_{\alpha \in \Gamma} E_{3+}(\alpha) \quad (3.24)$$

where, as in Step 5,  $E_{3+}(\alpha) = \{z \in B \mid z_3 \geq \alpha > z_j \text{ for all } j \in N \setminus 3\}$ . For instance, we may choose  $\Gamma = \{\frac{1}{2k}, \frac{2}{2k}, \dots, \frac{2k-1}{2k}\}$ . From (3.23) and (3.24) follows that there exists  $\alpha \in \Gamma$  such that  $\mu_3^b(E_{3+}(\alpha)) > 0$ . By (3.16) in Step 5, there must exist some  $i \in N \setminus 3$  such that

$$\mu_i^b(E_{3+}(\alpha)) > 0. \quad (3.25)$$

Since the choice of agents 1 and 2 in Step 1 and the choice of agent 3 in Steps 4 and 5 was arbitrary, an equation analogous to (3.13) holds for agent  $i$  as well, namely,

$$\mu_i^b(D^{N \setminus i}) = \mu_i^b(B).$$

But  $E_{3+}(\alpha) \subseteq B \setminus D^{N \setminus i}$  (since  $z \in E_{3+}(\alpha) \Rightarrow z_j \neq z_3$  for all  $j \in N \setminus 3 \Rightarrow z_j \neq z_3$  for all  $j \in N \setminus \{3, i\} \Rightarrow z_j \neq z_k$  for some  $j, k \in N \setminus i \Rightarrow z \in B \setminus D^{N \setminus i}$ ). Therefore  $\mu_i^b(E_{3+}(\alpha)) \leq \mu_i^b(B \setminus D^{N \setminus i}) = 0$ , contradicting (3.25). This proves (3.22).

Since the support of  $\mu_3^b$  is included in the diagonal of  $B$ , it follows from (3.1) that  $\mu_3^b$  is uniquely determined and, by definition of the serial weight system,  $\mu_3^b = \mu_3^{*b}$ . Since the choice of agents 1 and 2 in Step 1 and the choice of agent 3 in Steps 4 and 5 was arbitrary,  $\mu_i^b = \mu_i^{*b}$  for all  $i \in N$ .

**Step 7.** We identify a key restriction imposed on  $\mu$  by the Dummy Independence axiom. Let  $x \in \mathbb{R}_+^N$  and  $X = [0, x]$ . Define the demand profile  $x(12) = (x_1, x_2, 0, \dots, 0)$ , and let  $X(12) = [0, x(12)]$ . We claim that for all  $E \in \mathcal{E}^o$  such that  $E \cap X(12) \neq \emptyset$ ,

$$\mu_i^{x(12)}(E \cap X(12)) = \mu_i^x(E \cap X) \text{ for } i = 1, 2. \quad (3.26)$$

Let  $E = ]e^-, e^+[$ , with  $e^- \ll e^+$ . Since  $E \cap X(12) \neq \emptyset$ , we have  $e_i^+ > 0$  for  $i = 1, 2$ . Define  $e_{i+}^- = \max(e_i^-, 0)$ . For  $m = 3, 4, \dots$ , let

$$E^m = \{z \in E \mid e_{i+}^- + \frac{1}{m}(e_i^+ - e_{i+}^-) \leq z_i \leq e_i^+ - \frac{1}{m}(e_i^+ - e_{i+}^-) \text{ for } i = 1, 2\}.$$

Fix a real number  $k > 0$  and let  $(C^m)_{m=3,4,\dots}$  be a sequence of cost functions such that, for all  $m$ , (a)  $C^m(z)$  is independent of  $z_3, \dots, z_n$ , (b)  $\partial_1 C^m(z) = k$  if  $z \in E^m \cap \mathbb{R}_+^N$ , (c)

$\partial_1 C^m(z) \leq k$  if  $z \in E \cap \mathbb{R}_+^N$ , and (d)  $\partial_1 C^m(z) = 0$  if  $z \in \mathbb{R}_+^N \setminus E$ . See Figure 8 for an illustration. Then,

$$\begin{aligned} k\mu_1^{x(12)}(E^m \cap X(12)) &\leq \varphi_1(C^m, x(12)) \leq k\mu_1^{x(12)}(E \cap X(12)), \\ k\mu_1^x(E^m \cap X) &\leq \varphi_1(C^m, x) \leq k\mu_1^x(E \cap X). \end{aligned}$$

Since  $\lim_{m \rightarrow \infty} \mu_1^{x(12)}(E^m \cap X(12)) = \mu_1^{x(12)}(E \cap X(12))$  and  $\lim_{m \rightarrow \infty} \mu_1^x(E^m \cap X) = \mu_1^x(E \cap X)$ , we have  $\lim_{m \rightarrow \infty} \varphi_1(C^m, x(12)) = k\mu_1^{x(12)}(E \cap X(12))$  and  $\lim_{m \rightarrow \infty} \varphi_1(C^m, x) = k\mu_1^x(E \cap X)$ . By Dummy Independence,  $\varphi_1(C^m, x(12)) = \varphi_1(C^m, x)$  for all  $m$ . Since  $\varphi_1(\cdot, x(12))$  and  $\varphi_1(\cdot, x)$  are continuous (because they are of the form given in (3.3)), it follows that  $\lim_{m \rightarrow \infty} \varphi_1(C^m, x(12)) = \lim_{m \rightarrow \infty} \varphi_1(C^m, x)$ , hence  $\mu_1^{x(12)}(E \cap X(12)) = \mu_1^x(E \cap X)$ . A completely similar argument shows that  $\mu_2^{x(12)}(E \cap X(12)) = \mu_2^x(E \cap X)$ .

**Step 8.** We conclude the proof.

**8.1.** Let  $b(12) = (\beta, \beta, 0, \dots, 0)$  and  $B(12) = [0, b(12)]$ . We claim that

$$\mu^{b(12)} = \mu^{*b(12)}. \quad (3.27)$$

From Step 7,  $\mu_i^{b(12)}(E \cap B(12)) = \mu_i^b(E \cap B)$  for  $i = 1, 2$  and all  $E \in \mathcal{E}^o$  such that  $E \cap B(12) \neq \emptyset$ . Using Step 6, it follows that  $\mu_i^{b(12)}(E \cap B(12)) = \mu_i^{*b}(E \cap B) = 0$  for  $i = 1, 2$  and all  $E \in \mathcal{E}^o \cap (\mathcal{E}_< \cup \mathcal{E}_>)$ . This means that for  $i = 1, 2$  the support of  $\mu_i^{b(12)}$  is included in  $\{z \in B(12) \mid z_1 = z_2\}$ , the diagonal of  $B(12)$ . Then (3.27) follows because of (3.1) and because  $b_i(12) = 0$  for  $i = 3, \dots, n$ .

**8.2.** Fix a real number  $\alpha$  such that  $0 \leq \alpha < \beta$  and consider the demand profile  $x = (\alpha, \beta, 0, \dots, 0)$ . We claim that

$$\mu^x = \mu^{*x}. \quad (3.28)$$

Because Group Demand Monotonicity implies Demand Monotonicity,  $\varphi_1(C, x) \leq \varphi_1(C, b(12))$  for all  $C \in \mathcal{C}$ . As Friedman and Moulin (1999) show (see step 3 of the proof of their Theorem 1), this implies that  $\mu_1^x$  and  $\mu_1^{b(12)}$  coincide on  $[0, x]$ . Because of (3.1) and (3.2), it follows that  $\mu_i^x = p_x \mu_i^{b(12)}$  for  $i = 1, 2$ . Hence, hence by Step 8.1 and the definition of the serial weight system  $\mu^*$ ,  $\mu_i^x = p_x \mu_i^{b(12)} = p_x \mu_i^{*b(12)} = \mu_i^{*x}$  for  $i = 1, 2$  and (3.28) follows because  $x_i = 0$  for  $i = 3, \dots, n$ .

**8.3.** Let  $x$  be an arbitrary demand profile such that  $0 \leq x \leq b$ . For any two distinct  $i, j \in N$ , let  $x(ij) = (x_{\{i,j\}}, 0_{N \setminus \{i,j\}})$ . Since the choice of agents 1, 2 in Steps 7, 8.1, and 8.2 was arbitrary, (3.26) and (3.28) generalize:

$$\mu_k^{x(ij)}(E \cap X(ij)) = \mu_k^x(E \cap X) \text{ for } k = i, j \text{ and all } E \in \mathcal{E}^o \text{ such that } E \cap X(ij) \neq \emptyset$$

and

$$\mu^{x(ij)} = \mu^{*x(ij)}.$$

Since these two facts hold for all distinct  $i, j \in N$ , the support of  $\mu^x$  must equal  $S^{*x}$ , the support of  $\mu^{*x}$  defined in (3.5). Because of (3.1), any weight system at  $x$  whose support equals  $S^{*x}$  coincides with  $\mu^{*x}$ . Thus  $\mu^x = \mu^{*x}$ . Since  $\beta$  is arbitrary, we conclude that  $\mu = \mu^*$ , hence  $\varphi = \varphi^*$ . ■



## 4. Discussion

(1) The only other existing axiomatization of the Friedman-Moulin serial method in the continuous cost-sharing model used in the current paper is the one we alluded to in the Introduction. Theorem 2 in Friedman and Moulin (1999) states that the serial method is characterized by Additivity, Dummy, Demand Monotonicity, and Upper Bound for Homogenous Goods. This last axiom says that if goods are perfect substitutes, namely,  $C(z) = c(\sum_{i \in N} z_i)$ , then  $\varphi_i(C, x) \leq C(x_i, \dots, x_i)$  for all  $x \in \mathbb{R}_+^N$  and  $i \in N$ . As we argued earlier, this powerful property is intimately connected with the very definition of the serial method. In fact, it rules out virtually all the popular cost-sharing methods. The only noticeable exception we are aware of is the so-called “cross-subsidizing serial method” of Moulin and Sprumont (2006) which differs from the Friedman-Moulin method but retains its serial structure. By contrast, Group Demand Monotonicity is satisfied by methods such as equal or proportional cost sharing.

In the discrete version of the cost-sharing model (that is, when demands are integers and the cost function is defined over  $\mathbb{N}^N$ ) Moulin and Sprumont (2006) offer an axiomatization of the (proper reformulation of the) Friedman-Moulin serial method based on Distributivity. That property states that the cost-sharing method should commute with the composition of cost functions. It is a technical axiom akin to Additivity with no clear normative or strategic interpretation. By contrast, Group Demand Monotonicity, is meaningful on both counts.

Still in the discrete framework, Sprumont (2008) studies a combination of axioms very closely related to the one we use. The main difference is that his axiom of Independence of Dummy Changes is strictly stronger than the combination of Weak Dummy and Dummy Independence, as the example of the Aumann-Shapley method shows. Moreover, his version of Anonymity is stronger than ours. In spite of this, Sprumont’s (2008) axioms fail to uniquely characterize the serial method: they circumscribe the class of so-called “nearly serial” methods. The use of the continuous framework allows us to obtain a much crisper result.

(2) The axioms used in our theorem are independent.

A cost-sharing method satisfying all our axioms but Additivity is equal sharing among the non-dummy agents: given a problem  $(C, x)$ , let  $N(C) = \{i \in N \mid \exists z \in \mathbb{R}_+^N : \partial_i C(z) > 0\}$ ,  $\varphi_i(C, x) = C(x)/|N(C)|$  if  $i \in N(C)$  and  $\varphi_i(C, x) = 0$  if  $i \in N \setminus N(C)$ .

A method violating only Weak Dummy is plain egalitarianism,  $\varphi_i(C, x) = C(x)/n$ .

A simple example of a method violating only Dummy Independence is proportionality:  $\varphi_i(C, x) = x_i C(x) / \sum_{j \in N} x_j$  if  $x > 0$  and  $\varphi_i(C, 0) = 0$ . This rule, however, violates Dummy. For an example that also satisfies Dummy, combine the serial method with the Shapley-Shubik method: let  $\varphi_i(C, x) = \varphi_i^*(C, x)$  if  $|\{j \in N \mid x_j > 0\}| \geq 3$  and  $\varphi_i(C, x) = \varphi_i^{SS}(C, x)$  otherwise, where the Shapley-Shubik method  $\varphi^{SS}$  charges agent  $i$  her Shapley value in the “stand-alone game”  $\gamma_{(C, x)}(S) = C(x_S, 0_{N \setminus S})$  for all  $S \subseteq N$ . This method satisfies Group Demand Monotonicity because the Shapley-Shubik method satisfies Demand Monotonicity.

For a method violating only Anonymity, consider any so-called “fixed-path method”

other than the serial method: the simplest example is the so-called “incremental” method  $\varphi_i(C, x) = \gamma_{(C, x)}(\{1, \dots, i\}) - \gamma_{(C, x)}(\{1, \dots, i - 1\})$ .

Finally, the Aumann-Shapley method and the Shapley-Shubik method are examples of methods violating only Group Demand Monotonicity.

(3) The proof of our theorem does not use the full power of Group Demand Monotonicity. In fact, this axiom may be replaced with the weaker requirement that members of groups of size one or two cannot all lower their cost shares by jointly raising their demands. But Demand Monotonicity would not suffice: numerous demand-monotonic methods, including the Shapley-Shubik method, satisfy our first four axioms.

(4) One think of axioms of responsiveness to marginal costs that would strengthen Dummy. One very natural requirement would stipulate that if the marginal cost function associated with an agent increases, that agent should not end up paying less: if  $\partial_i C^1(z) \leq \partial_i C^2(z)$  for all  $z \in \mathbb{R}_+^N$ , then  $\varphi_i(C^1, x) \leq \varphi_i(C^2, x)$  for all  $x \in \mathbb{R}_+^N$ . This property is automatically satisfied by every additive method satisfying Dummy, including the serial method, because of the Friedman-Moulin lemma (see formula (3.3)).

In the same spirit of cost responsiveness, Young (1985) proposed a powerful condition dubbed Symmetric (Cost) Monotonicity: if  $\partial_i C^1(z) \leq \partial_j C^2(z)$  for all  $z \in [0, x]$ , then  $\varphi_i(C^1, x)/x_i \leq \varphi_j(C^2, x)/x_j$ . The fact, proved by Young, that only the Aumann-Shapley method possesses this property illustrates the trade-off existing between the fundamental desiderata of responsiveness to marginal costs and responsiveness to demand sizes. In our interpretation of the cost-sharing model where each good is consumed by a clearly identifiable agent, Symmetric Monotonicity is not compelling because average cost shares have no particular ethical relevance.

(5) One can also think of axioms of responsiveness to demand size that would strengthen Group Demand Monotonicity. One such property is Strong Group Demand Monotonicity: the sum of the cost shares of the agents in a group should not decrease when they jointly raise their demands. This condition is violated by the serial method<sup>3</sup>. In fact, one can show (by adapting the arguments in Moulin and Sprumont (2005) to our continuous model) that no additive method satisfies Strong Group Demand Monotonicity and Dummy. This fact is another illustration of the trade-off between cost responsiveness and demand responsiveness within the class of additive methods. It also shows how restrictive Additivity is. Indeed, it is easy to construct non additive methods satisfying Dummy and Strong Group Demand Monotonicity: equal sharing among the non-dummy agents is a very simple example; it actually satisfies the condition that *none* of the agents who jointly raise their demand pays less.

---

<sup>3</sup>A much more modest strengthening of Group Demand Monotonicity would require that if  $x_i < x'_i$  for all  $i \in S$  and  $x_i = x'_i$  for all  $i \in N \setminus S$ , then either there exists  $i \in S$  such that  $\varphi_i(C, x) < \varphi_i(C, x')$  or else  $\varphi_i(C, x) = \varphi_i(C, x')$  for all  $i \in S$ . This condition too is violated by the serial method.

## 5. Appendix

We provide the proof of the claim made in Step 1.1. To do so, we begin by constructing a sequence of continuous functions  $C^m$  approximating the function  $C$  in (3.9). Recall that  $E = ]e^-, e^+[$  is an open interval below the plane  $z_1 = z_2$ . For  $m = 3, 4, \dots$ , and  $\lambda \in [0, 1]$ , define the set

$$E^m(\lambda) = \left\{ z \in E \mid \min\left(\frac{1}{m}, \frac{2\lambda}{m}\right) \leq z'_i \leq \min\left(1 - \frac{1}{m}, 1 - \frac{2\lambda}{m}\right) \text{ for } i = 1, 2 \right\}.$$

Figure 9 shows the set  $E_{\{1,2\}}^m(\lambda)$  for some values of  $\lambda$ . Observe that  $E^m(\frac{1}{2}) = \{z \in E \mid e_i^- + \frac{1}{m}(e_i^+ - e_i^-) \leq z_i \leq e_i^+ - \frac{1}{m}(e_i^+ - e_i^-) \text{ for } i = 1, 2\} \subseteq E^m(\lambda)$  for all  $\lambda \in [0, 1]$ . From now on we write  $E^m$  instead of  $E^m(\frac{1}{2})$ . Notice that

$$E^m \subseteq E^{m+1} \text{ for } m = 3, 4, \dots \text{ and } \bigcup_{m=3}^{\infty} E^m = E. \quad (5.1)$$

For  $m = 3, 4, \dots$ , and  $\lambda \in [0, 1]$ , define  $C_0^m(\cdot, \cdot, \lambda)$ ,  $C_1^m(\cdot, \cdot, \lambda)$  on  $\mathbb{R}_+^{\{1,2\}}$  by

$$\begin{aligned} C_0^m(z_1, z_2, \lambda) &= \max\left(0, \lambda m \min(z'_1, z'_2), \frac{1-m}{2} + \frac{m}{2}(z'_1 + z'_2)\right), \\ C_1^m(z_1, z_2, \lambda) &= \min\left(1, 1 - (1-\lambda)m \min(1 - z'_1, 1 - z'_2), \frac{1-m}{2} + \frac{m}{2}(z'_1 + z'_2)\right). \end{aligned}$$

Figure 10 illustrates the function  $C_0^m(\cdot, \cdot, \lambda)$  (for  $\lambda = \frac{3}{4}$ ) and the function  $C_1^m(\cdot, \cdot, \lambda)$  (for  $\lambda = \frac{1}{2}$ ). Define  $C^m : \mathbb{R}_+^N \rightarrow [0, 1]$  by

$$C^m(z) = \begin{cases} z_3'' & \text{if } (z_1, z_2) \in E_{\{1,2\}}^m(z_3''), \\ C_0^m(z_1, z_2, \max(z_3'', \frac{1}{2})) & \text{if } (z_1, z_2) \notin E_{\{1,2\}}^m(z_3'') \text{ and } \frac{1-m}{2} + \frac{m}{2}(z_1' + z_2') \leq z_3'', \\ C_1^m(z_1, z_2, \min(z_3'', \frac{1}{2})) & \text{if } (z_1, z_2) \notin E_{\{1,2\}}^m(z_3'') \text{ and } \frac{1-m}{2} + \frac{m}{2}(z_1' + z_2') > z_3''. \end{cases}$$

See Figure 11. Because of (5.1), the sequence  $(C^m)_{m=3,4,\dots}$  converges pointwise to the function  $C$  defined in (3.9).

The functions  $C^m$  are not continuously differentiable. Our next step consists in smoothing them off. We begin by slightly modifying them to obtain functions that are continuously differentiable in  $z_3$ . Let  $k$  be a large positive real number. For  $m = 3, 4, \dots$ , let  $f^m : \mathbb{R}_+ \rightarrow [0, 1]$  be a continuously differentiable nondecreasing function such that (a)  $f^m(z_3) = z_3''$  whenever  $z_3 \leq e_3^-$  or  $e_3^- + \frac{1}{m}(e_3^+ - e_3^-) \leq z_3 \leq e_3^+ - \frac{1}{m}(e_3^+ - e_3^-)$  or  $e_3^+ \leq z_3$  and (b) the derivative of  $f^m$  is bounded above by  $k$ . Define  $C^{m,m} : \mathbb{R}_+^N \rightarrow [0, 1]$  by replacing  $z_3''$  with  $f^m(z_3)$  in the definition of the function  $C^m$  above. Notice that  $C^{m,m}$  coincides with  $C^m$  outside  $E$ . Because the sequence  $(f^m)_{m=3,4,\dots}$  converges pointwise to the function  $f(z_3) = z_3''$ , the sequence  $(C^{m,m})_{m=3,4,\dots}$  converges pointwise to the function  $C$  defined in (3.9).

Next, we modify the functions  $C^{m,m}$  to obtain functions that are also continuously differentiable in  $z_1$  and  $z_2$ . For  $m = 3, 4, \dots$  and  $\lambda \in [0, 1]$ , define  $E_\lambda^m = \{z \in E^m \cap \mathbb{R}_+^N \mid z_3'' = \lambda\}$  and  $E_\lambda = \{z \in E \cap \mathbb{R}_+^N \mid z_3'' = \lambda\}$ . Given a function  $\tilde{C} : \mathbb{R}_+^N \rightarrow [0, 1]$ , define

$$E(\tilde{C}, \lambda) = \left\{ z \in E \mid \tilde{C}(z) = \lambda \text{ and } z_3'' = \lambda \right\}.$$

Note that  $E(C, \lambda) = E_\lambda$ . Let  $(\tilde{C}^m)_{m=3,4,\dots}$  be a sequence of cost functions satisfying the following conditions:

$$\forall m = 3, 4, \dots \text{ and } z \notin E, \tilde{C}^m(z) = C^m(z), \quad (5.2)$$

$$\forall m = 3, 4, \dots \text{ and } \lambda \in \left[ \frac{1}{m+1}, 1 - \frac{1}{m+1} \right], E_\lambda^m \subseteq E(\tilde{C}^{m+1}, \lambda) \cap E_\lambda^{m+1}, \quad (5.3)$$

$$\forall \lambda \in [0, 1], E(\tilde{C}^m, \lambda) \rightarrow E_\lambda \text{ in the Hausdorff metric}, \quad (5.4)$$

$$\forall m = 3, 4, \dots \text{ and } z \in E, \partial_3 \tilde{C}^m(z) \leq k. \quad (5.5)$$

The construction of such a sequence causes no difficulty: see Figure 12 for an illustration.

We make two sets of claims regarding this sequence. First,

$$\tilde{C}^m \rightarrow C \text{ pointwise}, \quad (5.6)$$

where  $C$  is given in (3.9). To see why this is true, check first, using (5.4) and the continuity of the cost functions  $\tilde{C}^m$ , that for all  $\lambda \in [0, 1]$ ,  $\{z \in E \mid \tilde{C}^m(z) = \lambda\} \rightarrow E_\lambda$  in the Hausdorff metric. This in turn implies, using the continuity of the cost functions again, that for all  $z \in E$ ,  $\tilde{C}^m(z) \rightarrow C(z)$ . Combining this with (5.2) and the fact that  $C^m \rightarrow C$  pointwise yields (5.6).

Second, we claim that each cost function  $\tilde{C}^m$  has properties similar to  $C$ . Specifically, (a)  $\tilde{C}^m(a) = \tilde{C}^m(b)$ , (b)  $\tilde{C}^m(z)$  is independent of  $z_4, \dots, z_n$ , and (c)  $\partial_3 \tilde{C}^m$  is a positive constant on a set  $\tilde{E}(\tilde{C}^m)$  which tends to  $E \cap \mathbb{R}_+^N$  as  $m$  grows, and zero outside  $E \cap \mathbb{R}_+^N$ . Properties (a) and (b) are clear. As for (c), let  $E^{m,m} = \{z \in E^m \mid z_3'' \in [\frac{1}{m}, 1 - \frac{1}{m}]\}$  for  $m = 3, 4, \dots$  and notice that

$$\cup_{m=3}^\infty E^{m,m} = E. \quad (5.7)$$

For  $m = 3, 4, \dots$ , define the set

$$\tilde{E}^m = \left\{ z \in E^{m,m} \mid \tilde{C}^m(z_{-3}, \lambda e_3^+ + (1 - \lambda)e_3^-) = \lambda \text{ for all } \lambda \in \left[ \frac{1}{m}, 1 - \frac{1}{m} \right] \right\}.$$

By construction,

$$\partial_3 \tilde{C}^m(z) = \begin{cases} \frac{1}{e_3^+ - e_3^-} & \text{for all } z \in \tilde{E}^m, \\ 0 & \text{for all } z \notin E, \end{cases} \quad (5.8)$$

and we claim that

$$\tilde{E}^m \subseteq \tilde{E}^{m+1} \text{ for } m = 3, 4, \dots, \text{ and } \cup_{m=3}^\infty \tilde{E}^m = E \cap \mathbb{R}_+^N. \quad (5.9)$$

To prove this claim, fix  $m \geq 3$  and, for all  $\lambda \in [\frac{1}{m}, 1 - \frac{1}{m}]$ , let  $\tilde{E}^m(\lambda) = \{z \in \tilde{E}^m \mid z_3'' = \lambda\}$ . Using (5.3), it is straightforward to check that  $E_\lambda^m \subseteq \tilde{E}^{m+1}(\lambda)$  for all  $\lambda \in [\frac{1}{m+1}, 1 - \frac{1}{m+1}]$ , hence  $E^{m,m} \subseteq \tilde{E}^{m+1}$ , and the first statement in (5.9) follows. As for the second statement, we have  $\cup_{m=3}^\infty \tilde{E}^m = \cup_{m=2}^\infty \tilde{E}^{m+1} \supseteq \cup_{m=2}^\infty E^{m,m} = E$  because of (5.7).

We are now ready to complete the proof of Step 1.1. The function  $\tilde{C}_*^m$  defined on  $\mathbb{R}_+^N$  by

$$\tilde{C}_*^m(z) = \begin{cases} \tilde{C}^m(z) & \text{if } z_1 \geq z_2, \\ \pi^{12} \tilde{C}^m(z) & \text{otherwise,} \end{cases}$$

need not be a cost function because it may fail to be differentiable when  $z_1 = z_2$ . However, it is straightforward to construct a cost function  $\tilde{C}_*^{m,m}$  which (a) coincides with  $\tilde{C}_*^m$  whenever  $|z_1 - z_2| < \frac{1}{m}$ , (b) is symmetric in  $z_1, z_2$ , (c) is independent of  $z_4, \dots, z_n$ , and (d) is such that  $\partial_3 \tilde{C}_*^{m,m}(z) = 0$  for all  $z \notin E$ . For  $m$  large enough, (3.7) and (5.9) guarantee that  $p_a \mu_3^b(\tilde{E}^m \cap A) = \mu_i^b(\tilde{E}^m \cap B)$ . Using (5.8) and Anonymity,

$$\varphi_3(\tilde{C}_*^{m,m}, a) = \frac{2\mu_3^a(\tilde{E}^m \cap A)}{e_3^+ - e_3^-} + 2 \int_{(E \cap A) \setminus (\tilde{E}^m \cap A)} \partial_3 \tilde{C}^m d\mu_3^a$$

and

$$\begin{aligned} \varphi_3(\tilde{C}_*^{m,m}, b) &= \frac{2\mu_3^b(\tilde{E}^m \cap B)}{e_3^+ - e_3^-} + 2 \int_{(E \cap B) \setminus (\tilde{E}^m \cap B)} \partial_3 \tilde{C}^m d\mu_3^b \\ &= \frac{2p_a \mu_3^b(\tilde{E}^m \cap A)}{e_3^+ - e_3^-} + 2 \int_{(E \cap B) \setminus (\tilde{E}^m \cap B)} \partial_3 \tilde{C}^m d\mu_3^b. \end{aligned}$$

By (5.5),  $\int_{(E \cap A) \setminus (\tilde{E}^m \cap A)} \partial_3 \tilde{C}^m d\mu_3^a \leq k\mu_3^a((E \cap A) \setminus (\tilde{E}^m \cap A))$  for all  $m$ . By (5.9),  $\lim_{m \rightarrow \infty} \mu_3^a((E \cap A) \setminus (\tilde{E}^m \cap A)) = 0$ , hence  $\lim_{m \rightarrow \infty} \int_{(E \cap A) \setminus (\tilde{E}^m \cap A)} \partial_3 \tilde{C}^m d\mu_3^a = 0$ . Similarly,  $\lim_{m \rightarrow \infty} \int_{(E \cap B) \setminus (\tilde{E}^m \cap B)} \partial_3 \tilde{C}^m d\mu_3^b = 0$ . Therefore

$$\begin{aligned} &\lim_{m \rightarrow \infty} \left( \varphi_3(\tilde{C}_*^{m,m}, a) - \varphi_3(\tilde{C}_*^{m,m}, b) \right) \\ &= \frac{2}{e_3^+ - e_3^-} \lim_{m \rightarrow \infty} \left( \mu_3^a(\tilde{E}^m \cap A) - p_a \mu_3^b(\tilde{E}^m \cap A) \right) \\ &= \frac{2}{e_3^+ - e_3^-} \left( \mu_3^a(E \cap A) - p_a \mu_3^b(E \cap A) \right) < 0 \end{aligned}$$

by (5.9) and (3.8).

Because of (5.6),  $\tilde{C}_*^{m,m} \rightarrow C_*$  pointwise. Hence, since  $\varphi_3(\cdot, a)$  and  $\varphi_3(\cdot, b)$  are continuous (by (3.3)), there exists  $m$  such that  $\varphi_3(\tilde{C}_*^{m,m}, a) - \varphi_3(\tilde{C}_*^{m,m}, b) < 0$ . As in the sketch of the argument at the beginning of Step 1.1, budget balance, Dummy, and Anonymity now imply that  $\varphi_i(\tilde{C}_*^{m,m}, a) > \varphi_i(\tilde{C}_*^{m,m}, b)$  for  $i = 1, 2$ , contradicting Group Demand Monotonicity.

## 6. References

- Aumann, R.J., and Shapley, L. (1974). Values of Nonatomic Games. Princeton University Press, Princeton.
- Billera, L., and Heath, D. (1982). "Allocation of Shared Costs: A Set of Axioms Yielding a Unique Procedure," *Mathematics of Operations Research* 7, 32-39.
- Billera, L., Heath, D. and Raanan, J. (1978), "Internal Telephone Billing Rates –A Novel Application of Non-Atomic Game Theory," *Operations Research* 26, 956-965.
- Friedman, E. (2004), "Paths and Consistency in Additive Cost Sharing," *International Journal of Game Theory* 32, 501-518.
- Friedman, E., and Moulin, H. (1999). "Three Methods to Share Joint Costs or Surplus," *Journal of Economic Theory* 87, 275-312.
- Mirman, L., and Tauman, Y. (1982). "Demand Compatible Equitable Cost Sharing Prices," *Mathematics of Operations Research* 7, 40-56.
- Moulin, H. (1995). "On Additive Methods to Share Joint Costs," *Japanese Economic Review* 46, 303-332.
- Moulin, H., and Shenker, S. (1992). "Serial Cost Sharing," *Econometrica* 60, 1009-1037.
- Moulin, H., and Sprumont, Y. (2005). "On Demand Responsiveness in Additive Cost Sharing," *Journal of Economic Theory* 125, 1-35.
- Moulin, H., and Sprumont, Y. (2006). "Responsibility and Cross-Subsidization in Cost Sharing," *Games and Economic Behavior* 55, 152-188.
- Moulin, H., and Vohra, R. (2003). "A Representation of Additive Cost Sharing Methods," *Economics Letters* 80, 399-407.
- Shapley, L. (1953). "A Value for n-Person Games," in Contributions to the Theory of Games II (Kuhn, H.W., and Tucker, W., eds.), *Annals of Mathematics Studies* 28, Princeton University Press, Princeton.
- Shubik, M. (1962). "Incentives, Decentralized Control, the Assignment of Joint Costs, and Internal Pricing," *Management Science* 8, 325-343.
- Sprumont, Y. (1998). "Ordinal Cost Sharing," *Journal of Economic Theory* 81, 126-162.
- Sprumont, Y. (2008). "Nearly Serial Sharing Methods," *International Journal of Game Theory* 37, 155-184.
- Young, H.P. (1985). "Producer Incentives in Cost Allocation," *Econometrica* 53, 757-765.

Figure 1 :  $S^{*nc}$

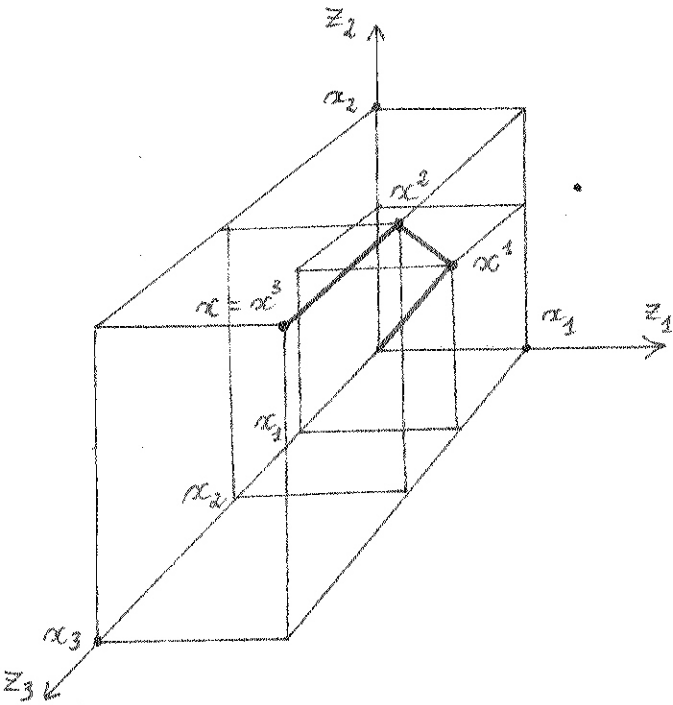

Figure 2 :  $C(z)$  for  $z_3 = \lambda e_3^+ + (1-\lambda)e_3^-$

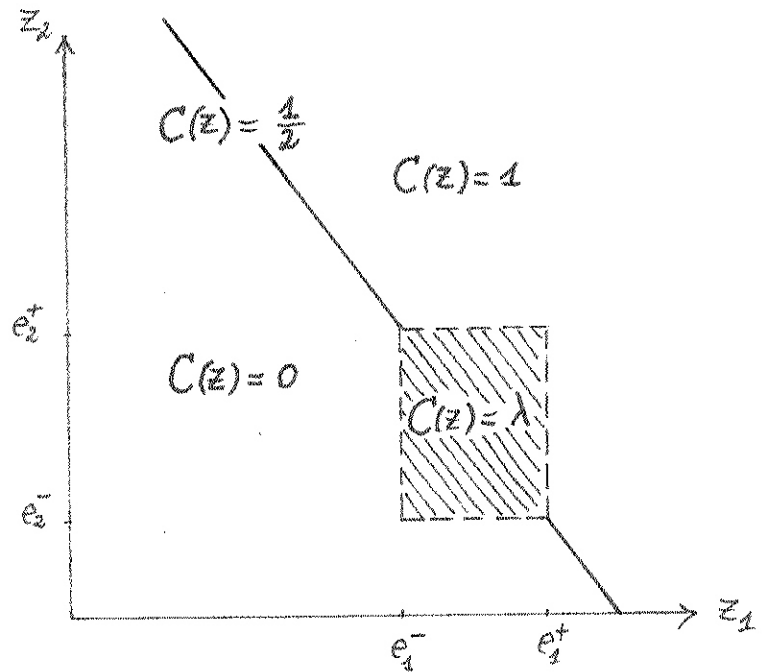

Figure 3 :  $h$

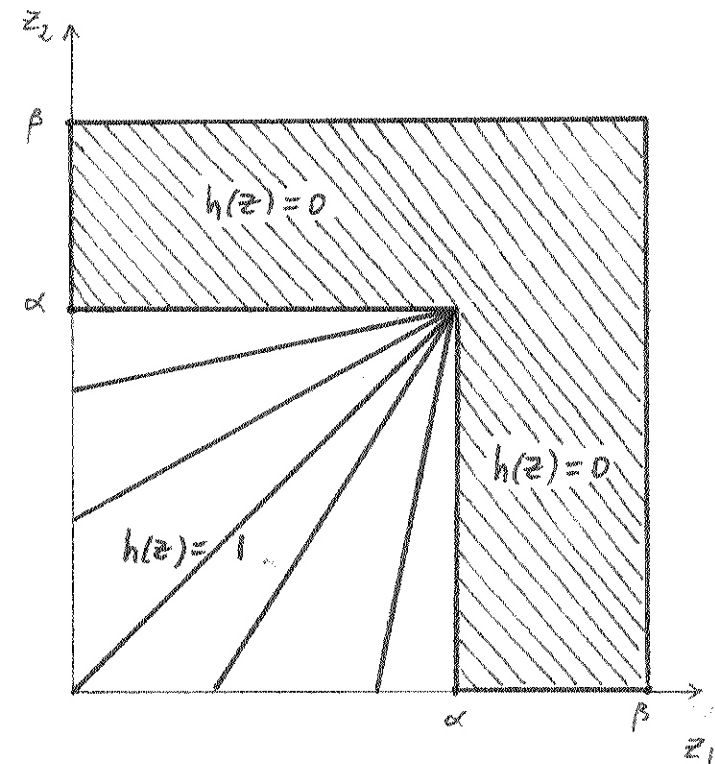

Figure 4 :  $C$

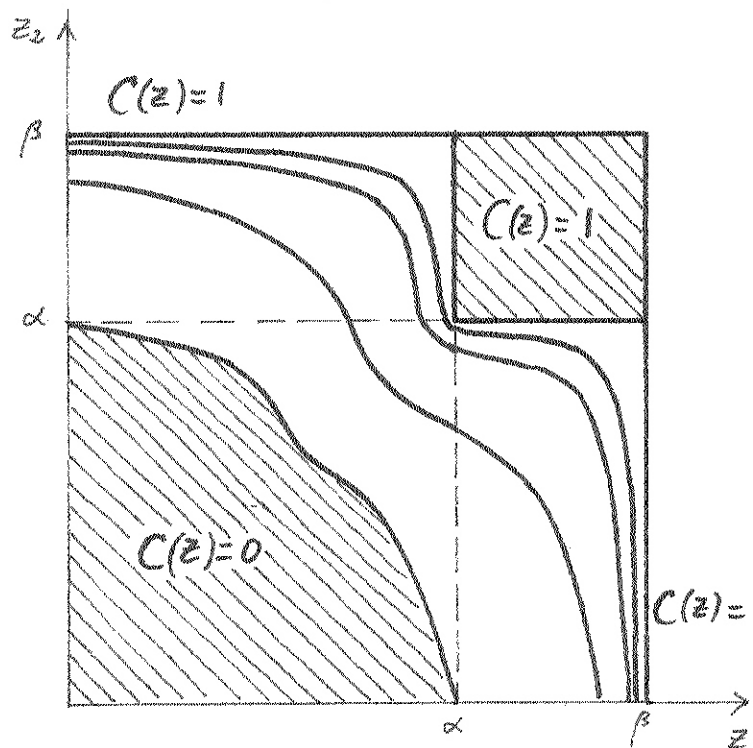

Figure 5 :  $D_3^{12}$

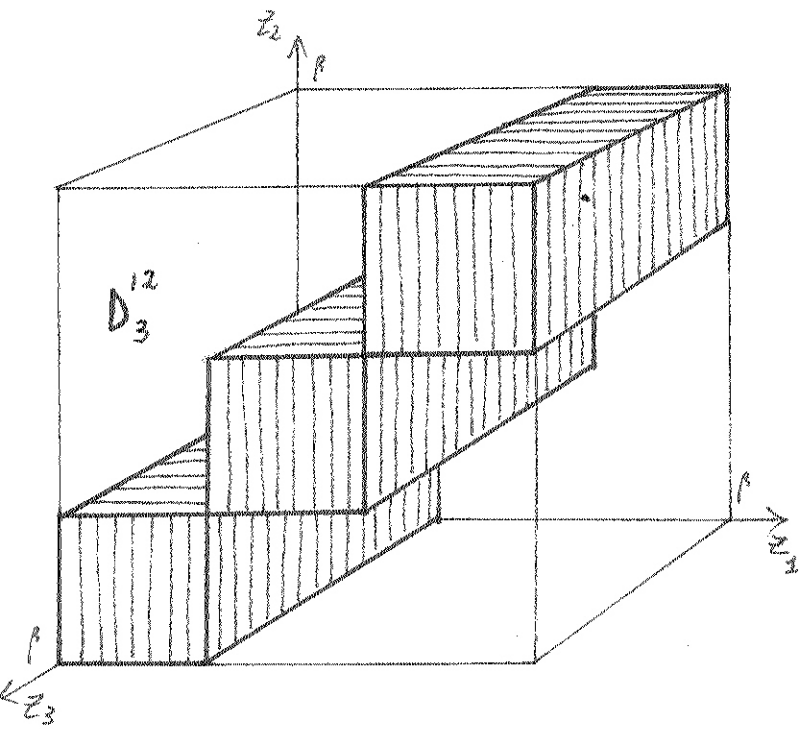

Figure 6 :  $E_{3+}(\alpha), E_{3-}(\alpha)$

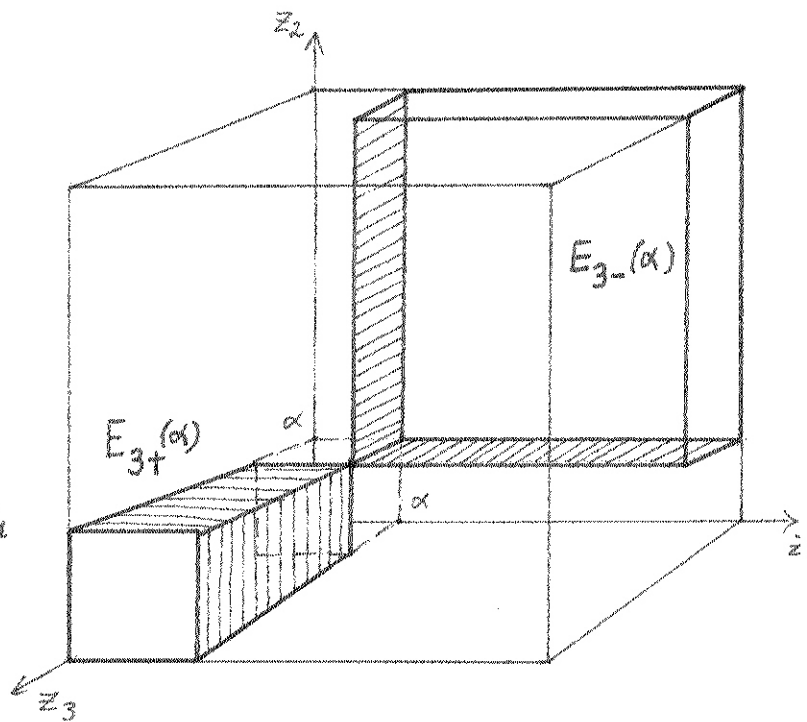

Figure 7 :  $D_+^{(1,2)}$

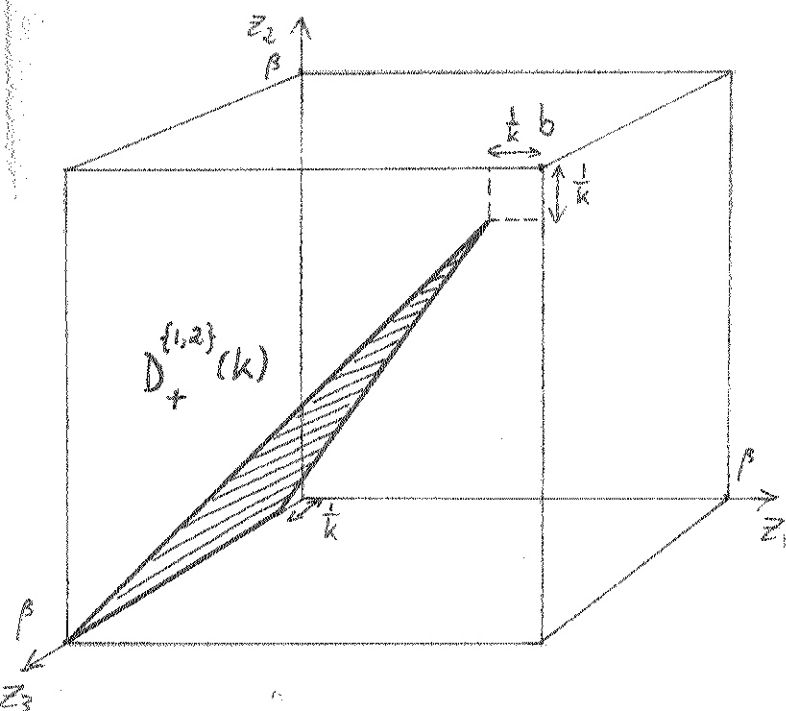

Figure 8 :  $C^m$

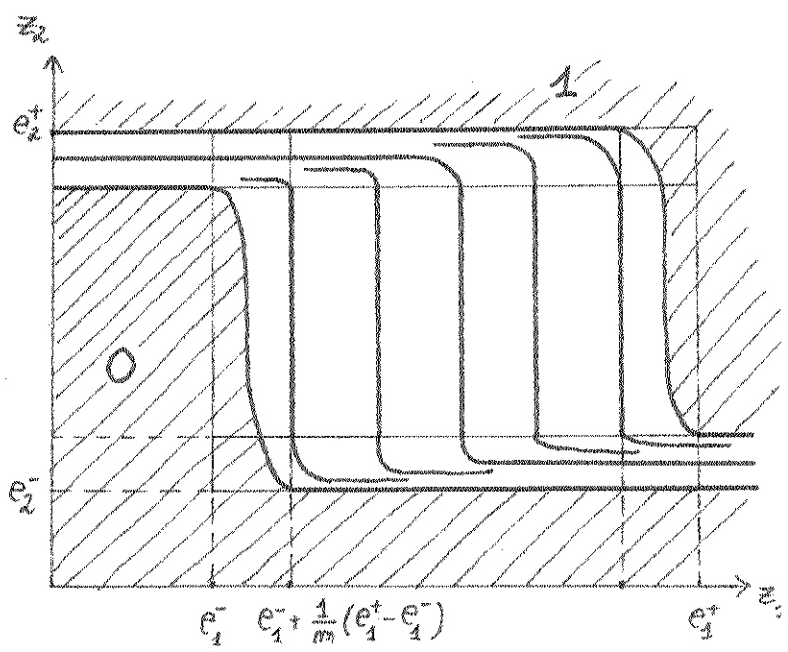



Figure 9:  $E_{(1,2)}^m(\frac{1}{4})$ ,  $E_{(1,2)}^m(\frac{3}{4})$

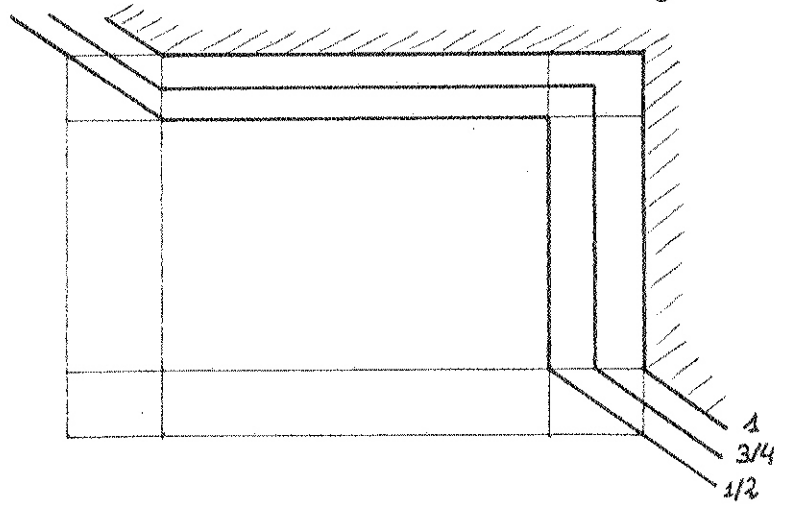
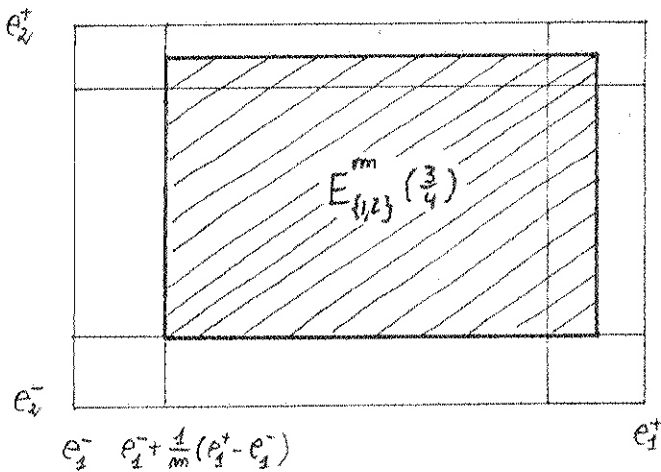
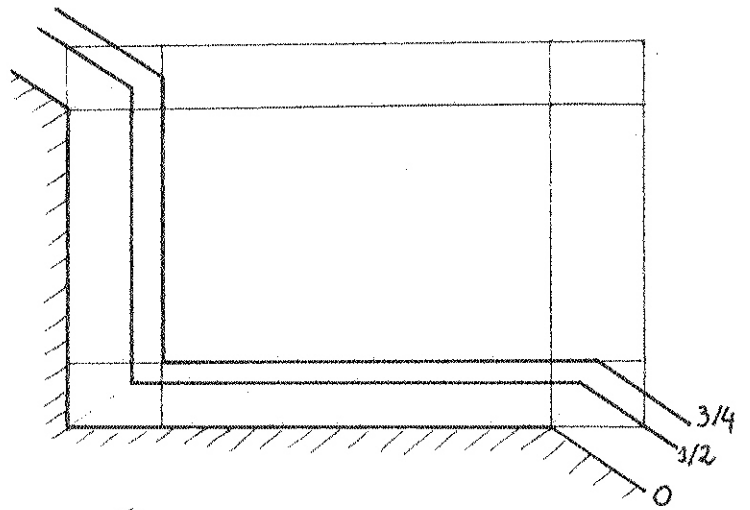
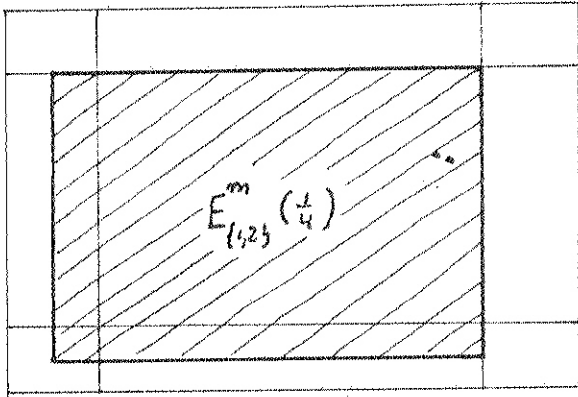

Figure 11:  $C^m(\cdot, \cdot, \frac{3}{4}e_3^+ + \frac{1}{4}e_3^-, z_4, \dots, z_n)$

Figure 12:  $\tilde{C}^m(\cdot, \cdot, \frac{3}{4}e_3^+ + \frac{1}{4}e_3^-, z_4, \dots, z_n)$

