

Associations Between Sibling Relationship Quality and Friendship Quality in Early Adolescence:

Looking at the Case of Twins

Mona Bekkhus¹ Mara Brendgen², Nikolai O. Czajkowski¹, Frank Vitaro³,

Ginette Dionne⁴, Michel Boivin^{4 5},

¹ Department of Psychology, University of Oslo, ²Université du Québec á Montréal, ³University of Montreal, ⁴Laval University, ⁵ Institute of Genetic, Neurobiological, and Social Foundations of Child Development, Tomsk State University, Russian Federation.

Running head: *Sibling relationship and friendship quality*

Correspondence to:

Mona Bekkhus,
University of Oslo,
Department of Psychology
Forskingsveien 3
0317 Oslo

Keywords: sibling relationship quality, friendship quality, best friend, twins.

Abstract

Bi-directional pathways between twin relationship quality and friendship quality were investigated in a large longitudinal twin cohort. We examined negative and positive relationship features in 313 monozygotic (MZ) twins and 238 same-sex dizygotic (DZ) twins from ages 13 to 14 years, using latent structural modelling. Results showed stronger stability of the twin relationship quality compared to friendship quality. Positive features in the sibling relationship were associated with increased positive features in the relationship with the best friend a year later. In contrast, no significant association between negative sibling relationship features and change in negative friendship quality features was found. These findings speak to the important role of the sibling relationship in the development of good quality friendship relations in twins.

Associations Between Sibling Relationship Quality and Friendship Quality in Early Adolescence: Looking at the Case of Twins

Within the family, siblings constitute an important source of influence on child development (Dunn, 2006; Dunn, & McGuire, 1992). Like all social relations, the sibling relationship involves both positive (Gass et al., 2007; Jenkins & Smith, 1990) and negative interactions (Bank et al., 2004; Patterson, 1984) that may have long-term effects on future adjustment, including the relationship with peers (Garcia et al., 2000). In line with this notion, a number of studies show that the quality of children's sibling relationship is predictively associated with the quality of their friendships (e.g. McCoy et al., 1994; Stocker & Dunn, 1990). However, these studies examined unidirectional associations between the sibling relationship and friendship quality. In addition, they used siblings with differences in age and thus possibly non-egalitarian relationships, although friends are often the same age and their relationship tends to be egalitarian (Ladd, 1983). The current study examined the bi-directional links between sibling relationship quality and friendship quality with a specific focus on twins. Looking at twin siblings specifically eliminates the age difference between siblings. It is also important given the increasing frequency of twin births in industrialized countries (e.g. Martin et al., 2012). However, although twins do not differ from single-born children in their behavior or their peer relationships (including their friendships) (Bekkhus et al., 2014; Boivin et al., 2013; Koch, 1966; Moilanen et al., 1999; Thorpe, 2003), their sibling relationship might be different. Yet, research focusing on the relationship between twins as a unique, egalitarian, form of sibling relationship is scarce, and associations between twin relationship quality and friendship quality have not yet been examined (Lamarche et al., 2006).

Starting in the womb, twin siblings develop alongside each other and are constantly present for mutual comparisons and shared experiences. Research shows that twins indeed spend more time together than other sibling dyads, and spend more time with each other than they spend with parents and other peers (Danby & Thorpe, 2006). Twin siblings also report a higher level of closeness compared to single birth siblings (Bekkhus et al., 2014; Fortuna et al., 2010). This is particularly the

case for monozygotic (MZ) twins who, compared to both same-sex and opposite sex dizygotic (DZ) twins, spend more time together and are more likely to have a shared friendship pool (Thorpe & Gardner 2006). Thus, twin siblings and especially MZ twins, experience not only a unique sibling relationship, but also a unique situation in regard to their friendship relations during childhood. However, there is still a question of whether this exceptional physical and emotional connection could be a potential hindrance for twins' social interaction with other peers, or whether their unique sibling relationship provides a special case of social learning and thus may have a positive impact on friendship relations (Lamarche et al., 2006). In the current study, this question was addressed by examining concurrent and longitudinal associations between the quality of the twin relationship and the quality of their friendship during early adolescence, an important period in which social relationships often shift from a focus on the family as the most important social context to that of peers (Berndt & Perry, 1986).

Links Between Twin-Sibling Relationships and Friendships

Close dyadic friendships with same-age peers, defined as voluntary, reciprocated, and egalitarian relationships between two individuals (Furman, 1996), are believed to provide an important source of emotional security and to play a central role in children's development (Sullivan, 1953; Price, 1996). In line with this notion, a number of studies have shown that the quality of children's friendship relations is associated with their emotional, cognitive, and behavioral development (Berndt & Perry, 1986; Dunn, 2006). Within the family context, the parent-child relationship has usually been identified as a key factor associated with the quality of children's friendships (e.g., Doyle et al., 2009; Furman & Rose, 2015; Liu, 2008). However, research over the past decade has shown that the relationship between siblings is also important for children's social adjustment (Dunn et al., 1994; Dunn, 2006; Modry-Mandell et al., 2007; Stormshak et al., 1996), as it might enhance social skills known to promote positive friendship relations (Lockwood et al., 2001). The argument is that, within their families, children learn how to relate and interact with others. In turn, interacting and playing with a sibling could have both

positive and negative effects on later friendship quality (Dunn, 2006). However, these studies are based on single-birth sibling dyads, which involve hierarchical interactions between a younger and an older sibling and thus implicate caregiving and teaching behaviors that may be, to some extent, similar to the parent-child relationship (Dunn, 1983; Azmitia & Hesser, 1993). Indeed, Dunn (1983) has emphasized the importance of distinguishing between complementary sibling relationships, which reflect hierarchical interactions, and reciprocal sibling relationships that reflect more egalitarian interactions. The latter can only be achieved with twins. It is thus conceivable that the quality of the twin relationship has an especially strong impact on children's social development, including the quality of their friendship relations.

The specific nature of this association, however, may vary depending on twin zygosity. Indeed, findings by Fortuna et al (2010) showed that MZ twins report more social contact and higher levels of closeness with each other compared to same-sex DZ twins (mixed-sex twins were not compared with MZ twins, in that study). The association between a positive quality of the twin relationship and a positive friendship quality may thus be more pronounced for MZ twins than for DZ same-sex twins. The converse pattern is also possible, however. For example, in a study by Zahn-Waxler et al. (1997), MZ twins who were cooperative and prosocial towards each other were found to be less empathic towards peers, whereas more cooperation among same-sex DZ twins was associated with higher levels of empathy towards peers. Based on these findings, we should expect a positive association between the twin relationship and friendship quality for DZ pairs and a negative or no association for MZ pairs. In line with this notion, Nozaki et al., (2012) found that positivity between siblings was associated with more problematic peer relations as rated by mothers among MZ twins, whereas it was associated with fewer peer problems in same-sex DZ twins. That study, however, did not include measures of the quality of friendship relations among the examined outcomes. As such, it is still unclear whether a twin sibling relation of good quality represents an asset or a hindrance for the development of good quality friendships in youth. An additional issue to be addressed in the current study is sex moderation. Findings with respect to both sibling

relationships and friendship relations suggest that girl-girl dyads are closer than boy-boy dyads (e.g., Campione-Barr & Smetana, 2010; Dunn, 2006; Fortuna, et al., 2010). Associations between positive twin relationship and friendship features may thus be especially strong in girl-girl dyads.

The Present Study

The main objective of the present study was to examine the concurrent, cross-sectional and longitudinal associations between the quality of the twin-sibling relationship and the quality of the relationship with the best friend. Secondly, we were interested in examining whether reciprocal sibling relationships that reflect more egalitarian interactions, like twin relationships, are associated with the quality of twins' friendship relationships, both concurrently and longitudinally). Of specific interest in this regard was the question of whether these associations differ for MZ and same-sex DZ twins. To this end, the present study, targeted the age-range from age 13 to 14. This is an important addition to the literature, as dyadic friendship relations become increasingly important for emotional and social support in adolescence compared to middle childhood (Berndt & Perry, 1986; Dunn, 2006). As in many previous studies (e.g. Bekkhus et al., 2011; Fortuna et al., 2010; Nozaki et al., 2012), only same-sex DZ twins were compared with MZ twins for two reasons. First, the mixed-sex twin relationship is only comparable to mixed-sex friendships. However, our friendship quality measure specifically pertained to same-sex friendships, because most close friendships are with same-age and with same-sex peers in early adolescence (Dunn, 2006). The current study not only examined sex main effects as previous studies have (e.g. Fortuna et al., 2010; Nozaki et al., 2012), but also tested for moderation effects of sex and zygosity in regard to the links between the twin relationship quality and friendship quality from ages 13 to 14 years. Following the rationale of previous studies (e.g. Adams & Laursen, 2007; Brendgen et al., 2013), positive and negative relationship features were examined separately.

Method

Participants

The 191 MZ twin pairs (100 female pairs) and 286 DZ same-sex twin pairs (71 female twin pairs) participating in this study were part of a population-based sample of 464 MZ and same-sex DZ twin pairs from the greater Montreal area, Canada, who were recruited at birth between November 1995 and July 1998. Zygosity was assessed by genetic marker analysis of 8-10 highly polymorphous genetic markers and twins were classified as MZ when concordant for every genetic marker. As is common practice in twin studies (e.g., Burt & Klump, 2013; Magnusson et al., 2013), zygosity was determined based on physical resemblance questionnaires at 18 months and again at age 9 years (Goldsmith, 1991; Spitz et al., 1996) when genetic material was insufficient or unavailable due to parental refusal (43% of cases). The comparison of zygosity based on genotyping with zygosity based on physical resemblance in a subsample of 237 same-sex pairs revealed a 94% correspondence rate, which is extremely similar to rates obtained in other studies (Magnusson et al., 2013; Spitz et al., 1996).

Eighty-seven per cent of the families were of European descent, 3 % were of African descent, 3% were of Asian descent, and 1% were Native North Americans. The remaining families did not provide ethnicity information. Demographic characteristics of the twin families were comparable to those of a sample of single births representative of urban centers in the province of Quebec, Canada. At the time of their child(ren)'s birth, 95 % of parents lived together; 66% of mothers and 60% of fathers were between 25 and 34 years old; 17% of mothers and 14% of fathers had not finished high school; 28% of mothers and 27% of fathers held a university degree; 83% of the parents held an employment; 10% of the families received social welfare or unemployment insurance; 30% of the families had an annual income of less than \$30,000.

The sample was followed longitudinally during early childhood focusing on child and family characteristics as well as in kindergarten, elementary school and high school focusing on children's social and academic development. The present study utilized data from the latter phase when children were 13 years (i.e., T1, mean age = 13.06 years, SD = 3.6 months) and 14 years (i.e., T2, mean age = 14.06 years, SD = 3.6 months) old. Overall average attrition in the sample was a

little more than 3% per year, such that 551 MZ and DZ same sex twins participated at the age of 14 years. The remaining sample consisted of 149 MZ boys and 164 MZ girls, 114 DZ boys and 124 DZ girls. These twins did not differ from those who were lost through attrition in regard to mother-rated anxiety or aggression at ages 18 to 48 months, parental education, parents' age, or family revenue, but there were fewer single parent families in the remaining study sample. Questionnaire data were collected during home visits at both T1 and T2. Active written consent from the twins and their parents was obtained. All instruments were approved by the Institutional Review Boards of the University of Quebec in Montreal and the Ste-Justine Hospital Research Center.

Measures

Relationship features. Self-reported Friendship Quality was measured using items based on the short version of the Network of Relationships Inventory (NRI) (Furman & Buhrmeister, 1985, 1992). The NRI has shown good internal consistency ($\alpha = .88$) and test-retest reliability ($r = .69$) (Furman, 1996; Furman & Buhrmester, 1985, 1992; Jackson & Warren, 2000; Stocker, 1994). It has also shown good predictive validity as indicated by negative correlations with mental health problems such depression symptoms ($r = -.33$) and conduct problems ($r = -.35$) (Stice et al. 2004; Stocker, 1994). The twins reported on whether they had a best friend or not at both Time 1 and Time 2, however the twins were not necessarily friends with the same person from one time to the next. Using a 5-point-likert scale (ranging from 0 'a little or not at all' to 4 'most of the time'), participants responded to six items referring to positive relationship features and four items referring to negative relationship features. Because the longitudinal associations between the quality of the twin-sibling relationship and the quality of the relationship with the best friend were examined using a latent cross-lagged model (see description of analyses below), the latent factors representing positive quality features and negative quality features were estimated using parcels. To this end, we combined the items based on content analyses for positive and negative quality into two parcels for each feature (Little, Cunningham, Shahar et al., 2002; Coffman & MacCallum,

2005). For positive quality, two parcels were computed based on the mean score of three items for each parcel, which reflected either egalitarian relationship features (i.e. Do you feel loved and appreciated by these people? Do these people pay attention to you? Do these people treat you like someone who is competent in different areas? Do these people pay attention to you?), or supportive relationship features (i.e., “When things are going badly, do you talk about your problems with these people so they can help you find solutions? Do these people help you to understand and resolve certain issues? When things aren't going well, can you count on these people to comfort you?). For the three egalitarian features, the inter-correlations at age 13 ranged from .49 to .61 (for friendship items) and from .54 to .70 (for twin relationship items). For the three support features inter-correlations at age 13 ranged from .69 to .70 (for friendship items) and .75 to .75 (for twin relationship items). At age 14, the inter-correlations for egalitarian features ranged from .51 to .62 (for friendship items) and from .64 to .73 (for twinship items). Inter-correlations for supportive features ranged from .71 to .77 (for friendship items) and from .73 to .79 (for twinship items).

Similarly, the four items measuring negative quality were combined into two two-item parcels, which reflected either aggression (i.e., “has it happened that you’ve gotten angry with one or another of these people?” and “are you shocked or bothered by the behavior of one or another of these people?”) or disagreement (i.e., “Does it happen that you disagree or quarrel with one or another of these people?” and “Does it happen that you disagree with one or another of these people?”). Inter-correlations for the items reflecting aggression at age 13 ranged from .46 (for friendship items) to .50 (for twinship items). For disagreement, the inter-correlation ranged from .58 (for friendship items) to .67 (for twinship items). At age 14, the inter-correlations were .48 (for friendship items) and .46 (for twinship items) for aggressive. For disagreement, the inter-correlations were .63 (for friendship items) and .69 (for twinship items).

----Insert Table 1a and b----

Analyses

Preliminary Analyses

Prior to fitting the latent cross-lagged model, the bivariate correlations between the observed variables (i.e. the parcels described above) used in the latent model were examined (see Table 1a for positive relationship features and Table 1b for negative relationship features). As shown in Table 1a, girls reported more positive features in the relationship with their co-twin and with their best friend than boys, both at age 13 and age 14. In contrast, no significant correlations were found between sex and negative features (Table 1b). In regard to associations between corresponding twin relationship and friendship quality variables, results showed high to moderate, positive concurrent associations between positive friendship features and similar twin features (i.e. egalitarian friendship features with egalitarian twin-ship features, and supportive friendship features with supportive twin-ship features), at both age 13 and age 14. Positive friendship features were also moderately and positively correlated with positive twin relationship features across measurement times. Lower, but also positive correlations were observed for the concurrent associations between negative friendship and twin relationship features at both measurement times, as well as for the cross-time correlations between negative friendship features and negative twin relationship features.

Main Analyses

The concurrent and longitudinal associations between the quality of the twin-sibling relationship and the quality of the relationship with the best friend were examined using longitudinal structural equation modeling. The analyses followed three subsequent steps. First, we were interested in examining measurement invariance in the measurement model across the four groups (i.e., two sex groups by two zygosity groups), in the second step we examined cross-group invariance of the latent variances before examining cross-group invariance of the latent associations in step 3. All analyses were performed using Mplus Version 7.0. (Muthén & Muthén, 2007) and IBM SPSS statistics Version 20. Correction for family dependence was based on the Sandwich or Huber/White variance estimator available in Mplus (Muthén & Muthén, 2007; Williams, 2000). Model fit was determined using Chi-square estimates, the comparative fit index (CFI, with acceptable values of .90 or higher), the Tucker Lewis Index (TLI, with acceptable values of .90 or

higher) (Bentler & Bonett, 1980) and the Root Mean Squared Estimate of Approximation (RMSEA, with acceptable values of .08 or less) (Browne & Cudeck, 1993). Nested models were tested using the Chi-square difference test (Satorra, 2009). Due to the non-independence of the data because of twinning, the scaling correction factor (co) for MLR was used to compute the Chi-square difference tests. Thus, the Robust Satorra-Bentler Chi-Square difference test (S-b chi-square) was computed by $TRd = (T0*c0 - T1*c1)/cd$ and the difference scaling correction factor $cd = (d0 * c0 - d1*c1)/(d0 - d1)$ (see Muthén & Muthén, 2007; Satorra, 2009; and www.statmodel.com for computation).

Results

Step 1: Invariance of the measurement model. In the first step of the analyses, we examined invariance of the measurement structure (i.e., the factor loadings) across the four groups in separate models for positive quality features and negative quality features. To this end, we compared a measurement model where all factor loadings were freely estimated, to a model where we constrained all factor loadings to be equal across gender and zygosity groups (we also allowed two residual correlations in the negative quality model, and four in the positive quality model, which were necessary to optimize model fit). All latent variances and covariance's were free to vary. There was no loss in model fit for either positive (*constrained*, CFI 0.961; TLI = 0.943; RMSEA = 0.076. versus *unconstrained*: CFI 0.966; TLI = 0.93; RMSEA = 0.090), or negative quality (*constrained*, CFI 0.976; TLI = 0.97; RMSEA = 0.056. versus *unconstrained*: CFI 0.965; TLI = 0.939; RMSEA = 0.08). Moreover, neither the chi-square difference test for positive quality features (s-b χ^2 (df =24) = 31.52, $p = 0.14$ cd= 1.075) nor the chi-square difference test for negative quality features was significant s-b χ^2 (df =24) = 25.5, $p = 0.38$; cd= 1.77).

Step 2: Invariance testing of the latent variances. Next, we added invariance constraints to the latent variances across the four groups in addition to measurement invariance. No significant difference was found for either positive quality features (s-b χ^2 (df =9) = 15.66, $p = 0.07$; cd= 0.37) or negative quality features (s-b χ^2 (df =12) = 12.76, $p = 0.39$; cd= 1.79) in the constrained models compared to the previous, unconstrained models. Model fit for the latent cross-lagged path model

was adequate for both positive quality (χ^2 (df = 76) = 142.04; co: 1.10, $p < 0.00$; CFI 0.96; TLI = 0.94; RMSEA = 0.077 (C.I. 0.06-0.09)), and for negative quality (χ^2 (df = 84) = 124.19; co: 1.19 $p < 0.00$; CFI 0.98; TLI = 0.97; RMSEA = 0.059 (C.I. 0.03-0.07)). Unstandardized estimates for the final constrained model are presented in Figure 1a and b.

Step 3 Structural model: Since no group differences were found in the measurement model or in the latent variances, we proceeded to testing group-invariance of the latent associations (i.e., covariances). Three sub-models were tested, where different pairs of paths in the cross-lagged models were constrained to be equal, first across sex and then across zygosity. In model A we constrained the stability paths, in model B we constrained the concurrent correlations, and in model C we constrained the cross-lagged paths.

----Insert Table 2a and b ----

----Insert Table 3a and b----

Results for the chi-square difference tests are provided in Tables 2a and 2b, for positive relationship features, and Tables 3a and 3b for negative relationship features. For positive relationship features there were no differences across sex (Table 2a) or zygosity (Table 2b), such that all parameter values in the latent cross-lagged model could be constrained to be equal across the four groups without loss in model fit. The chi-square difference between the final nested (i.e., constrained) model and the comparison model (where all latent covariance parameters were free to vary) was non-significant (s-b χ^2 (df = 18) = 16.18, $p = 0.59$; cd= 1.36). Model fit of the final constrained model of positive relationship features was adequate (χ^2 (df = 94) = 155.01; $p < 0.000$; co: 1.15; CFI 0.96; TLI = 0.96; RMSEA = 0.069 (C.I. 0.049-0.088)). Latent associations for the cross-lagged path model of positive relationship features are given in Figure 1a. As can be seen, the positive features of the twin relationship and friendship features from age 13 to 14 were both highly stable across time. However, as expected the stability was stronger for the twin relationship features as compared to the friendship relationship features. Moderate concurrent associations were also found between positive friendship features and positive twin relationship features at both age 13

and age 14 years. No significant cross-lagged association was found between positive friendship features at age 13 and subsequent positive twin relationship features at age 14. However, a higher level of positive relationship features between twins significantly predicted a higher level of positive relationship features in the twins' friendships, one year later.

The chi-square difference tests for negative relationship features also indicated that the cross-lagged paths could be constrained to be equal across sex (Table 3a) and zygosity (Table 3b). The chi-square difference between the final nested (i.e., constrained) model and the comparison model (where all latent covariance parameters were free to vary) was non-significant (s-b χ^2 (df = 18) = 11.17, p = 0.89; cd = 1.28). Model fit of the final constrained model of negative relationship features was adequate (χ^2 (df = 102) = 140.8; p < 0.000; co: 1.19; CFI 0.98; TLI = 0.97; RMSEA = 0.053 (C.I. 0.03-0.07)). As can be seen in Figure 1b, for both MZ and DZ same-sex twin pairs, negative friendship features at age 13 were moderately associated with negative friendship features one year later (age 14). A somewhat stronger stability was found for the negative features of the twin relationship from age 13 to age 14 years. Concurrent associations between negative friendship features and negative twin relationship features were also significant, albeit low, at each time point. Moreover, in contrast to the findings for positive relationship features, there were no significant cross-lagged associations between the negative friendship features and the negative features of the twin relationship.

---insert Figure a and b----

Discussion

A close relationship between twins has been hypothesized to be a potential hindrance for twin children's social interaction with peers (DiLalla, 2006; Hay & Preedy, 2006). Other researchers have offered a contrasting view, however, suggesting that a close relationship between twins may have a positive rather than a negative impact on social skills (e.g., understanding of another person's feelings and perspective) and thus possibly also on friendship relations (e.g., Lamarche et al., 2006). The current study examined these contrasting hypotheses by examining a

bidirectional cross-lagged model of the relations between the quality of twin children's sibling relationship, and the quality of a best friend in early adolescence. We also investigated whether these associations differ for MZ and same-sex DZ twins or by sex.

Latent path analyses showed that, for positive relationship features, the stability from age 13 to 14 was stronger for the twin relationship than for the friendship relation. There were, however, no differences in zygosity (or sex) in regard to these stability patterns. Twins (both MZs and same-sex DZs) not only share a joint history since before they are born, but they also spend much more time with each other than they do with peers (Thorpe & Danby, 2006). As such, a higher stability in the twin relationship quality compared to friendship quality would be expected. More interestingly, cross-lagged associations showed that MZ and same-sex DZ twins who reported more positive features in the relationship with their co-twin also experienced more positive features in the relationship with their best friend a year later. The reverse longitudinal association from positive friendship features to positive twin relationship features was not observed, however. One potential explanation for these findings might be that, if the twin relationship is characterized by high positive quality, both DZ and MZ adolescent twins support each other and also spend a considerable amount of time together. This finding stands in contrast to the hypothesis proposed by some scholars (e.g., Hay & Preedy, 2006) that closeness between twin siblings might restrict their interaction with other peers and thus be a hindrance for building and maintaining close social relationships with peers. Instead, our finding is in line with results from non-twin sibling studies, suggesting that interaction with siblings can provide an important context for learning social skills and therefore have a positive influence on friendship formations (Dunn, 2006). Since our findings also show that positive social interactions between twin siblings are stable over time, such consistent exposure to a positive sibling relationship may thus create a stable context for positive social learning, regardless of zygosity.

Negative aspects of the friendship and twin relationship quality were also relatively stable over a one-year period. In contrast to what we found for positive relationship features, there were

no significant cross-lagged associations between negative features of the sibling relationship and the relationship with the best friend. Why would negative interactions with the co-twin not influence friendship relationships in the same way as positive interactions? Conflict between twins may be relatively normative and perhaps be resolved relatively quickly, since twins cannot simply walk away from their relationship in case of conflict (unfortunately, conflict resolution was not measured in the present study). Therefore, even frequent quarrels between twins may not necessarily spill over to friendship relations. It is also possible that the assessed time interval may be too long to observe potential spill-over effects from twin sibling conflicts to conflict with friends. Unlike sibling relationships, friendships are voluntary relationships that can be dissolved. Assuming that any spill-over effects from twin sibling conflicts to conflict with friends may occur rather rapidly, the twins may no longer be friends with the same person one year later and thus have completed the friendship quality questionnaire with respect to a different “best friend” than the year before. Future studies that assess information about the friends’ identity are necessary to explore this hypothesis.

Similar to other studies focusing on the twin relationship (e.g., Fortuna et al., 2010; McGuire & Segal 2013; Zahn-Waxler et al., 1997), we found a main effect of sex indicating that girl-girl dyads were closer and experienced fewer conflicts than boy-boy dyads. No sex-moderation was observed, however, as all of the observed associations were the same for girls and boys. Previous studies also found a main effect of zygosity, suggesting that MZ twins have a closer and more enduring relationship than DZ same-sex twins (Segal et al., 2008; Cassell, 2011; Thorpe & Gardner, 2006). No main effect of zygosity was observed for either positive or negative relationship features in our study, however. Moreover, all of the observed associations were the same for MZ and DZ twins. The lack of main and moderation effects of zygosity could potentially be due to the age period examined in our study. That is, during early adolescence, the co-twin (regardless of whether it is DZ or MZ) might be an important source of emotional support in the same way as a friend, even if the relationship is conflicted.

Strengths, Limitations and Conclusion

This is the first study to examine the potential bidirectional longitudinal links between the quality of the relationship between twins and the quality of twins' friendship relations. The study has several strengths. One strength is the use of self-reports for both the twin relationship quality and friendship quality, which can be assumed to be more accurate than maternal ratings of the sibling relationship used in some other studies (e.g. Bekkhus et al., 2014; Fortuna et al., 2010; Nazaki et al., 2012). During adolescence, when children become more independent, parents are less likely to be able to be privy about their offspring's friendships outside the home. Another strength is that we used repeated measures of both sibling relationship quality and friendship quality, enabling us to disentangle the directionality of longitudinal associations while controlling for stability and cross-sectional links of the two types of relationships.

Against that background, some limitations of this study should be mentioned. First, our study only focused on the qualitative aspects of the twins' sibling relationship and how that relates to the quality of the relationship with a best friend, rather than to the number of reciprocal friends or position in a social network of peers. It is possible that the dynamic and quality of the twin relationship is differentially related to how the twins interact with a group of peers compared with just one (best) friend. In addition, our findings are limited to a one-year interval between age 13 and 14. It would be interesting to examine both a more short-term and a longer-term association between the twins' sibling relationship and their friendship quality and also examine developmental differences in the associations between the two types of relationships. Finally, it is important to note that the results from the present study, which focused on the quality of twins' relationship with each other and with their best friends, do not necessarily generalize to siblings issued from single births.

Despite these limitations, we believe this study provides novel insights into the associations of the inter-twin relationship with twins' social experiences outside the home. Our findings suggest that a highly positive twin sibling relationship is associated with an increasingly positive

relationship with friends. Thus, a caring and supportive twin relationship may help twin children develop the skills necessary to also establish a positive relationship with others.

References

- Adams, R. E., & Laursen, B. (2007). The correlates of conflict: Disagreement is not necessarily detrimental. *Journal of Family Psychology, 21*(3), 445-458. doi: 10.1037/0893-3200.21.3.445
- Azmitia, M., & Hesser, J. (1993). Why siblings are more important agents of cognitive development: A Comparison of siblings and peers. *Child Development, 64*, 430-444.
- Bank, L., Burrastone, B., & Snyder, J. (2004). Sibling conflict and ineffective parenting as predictors of adolescent boys antisocial behaviour and peer difficulties: additive and interactional effects. *Journal of Research on Adolescence, 14*, 99-125.
- Bekkhuis, M. Staton, S. Borge, A.I.H & Thorpe, K. (2014). Do twins differ from single-born children on rates of behavioural difficulty in early childhood? A study of sibling relationship risk factors. *Twin Research and Human Genetics, 17*, (4), 288-295.
- Bekkhuis, M. Staton, S. Borge, A.I.H & Thorpe, K. (2011). Conflict, closeness and comfort: The inter-twin relationship as a risk factor for behavioral difficulties. *Twin Research and Human Genetics, 14*: 444-451.
- Bentler, P. M., & Bonett, D. G. (1980). Significance tests and goodness of fit in the analysis of covariance structures. *Psychological Bulletin, 88*, 588-606.
- Berndt, T. J., & Perry, T. B. (1986). Children`s perception of friendships as supportive relationships. *Developmental Psychology, 22*, 640-648.
- Boivin, M., Brendgen, M., Vitaro, F., Dionne, G., Girard, A., Pérusse, D., & Tremblay, R. E. (2013). Strong Genetic Contribution to Peer Relationship Difficulties at School Entry: Findings From a Longitudinal Twin Study. *Child Development, 84* (3), 1098-1114. doi: 10.1111/cdev.12019
- Brendgen, M., Vitaro, F., Bukowski, W. M., Dionne, G., Tremblay, R. E., & Boivin, M. (2013). Can friends protect genetically vulnerable children from depression? *Development and Psychopathology, 25*(02), 277-289. doi: 10.1017/S0954579412001058

- Browne, M. W., & Cudeck, R. (1993). *Alternative ways of assessing model fit*. Newbury Park: Sage.
- Burt, S. A., & Klump, K. L. (2013). The Michigan state university twin registry (MSUTR): an update. *Twin Research and Human Genetics*, *16*(01), 344-350.
- Campione-Barr, N., & Smetana, J. G. (2010). "Who said you could wear my sweater?" Adolescent siblings' conflicts and associations with relationship quality. *Child Development*, *81*, 464-471.
- Cassell, S. (2011). Examining the Twin Bond: A look at the psychological development of twins and the differences in individuality and identity differentiation between fraternal and identical same-sex twins. American University.
- Coffman, D. L., & MacCallum, R. C. (2005). Using parcels to convert path analysis models into latent variable models. *Multivariate Behavioral Research*, *40*(2), 235-259.
- Danby, S. & Thorpe, K. (2006). Compromised or competent: Analysing twin children's social worlds. *Twin Research and Human Genetics*, *9*, 90-94.
- Doyle, A., Lawford, H., & Markiewicz, D. (2009). Attachment style with mother, father, best friend, and romantic partner during adolescence. *Journal of Research on Adolescence*, *19*, 690-714. doi:10.1111/j.1532-7795.2009.00617.x
- DiLalla, L. F. (2006). Social development of twins. *Twin Research and Human Genetics*, *9*, 95-102.
- Dunn, J. (1983). Sibling relationships in early childhood. *Child Development*, *54*, 787-811.
- Dunn, J. (2006). Children's friendships. *The beginnings of intimacy*. London, UK.: Blackwell publishing Ltd.
- Dunn, J., & McGuire, S. (1992). Sibling and peer relationships in childhood. *Journal of Child Psychology and Psychiatry*, *33*, 67-105.
- Dunn, J., Slomkowski, C., Beardsall, L. and Rende, R. (1994), Adjustment in middle childhood and early adolescence: Links with earlier and contemporary sibling relationships. *Journal of Child Psychology and Psychiatry*, *35*: 491-504. doi: 10.1111/j.1469-7610.1994.tb01736.x

- Fortuna, K., Goldner, I., & Knafo, A. (2010). Twin relationships: A comparison across monozygotic twins, dizygotic twins and nontwin siblings in early childhood. *Family Science, 1*, 205- 211.
- Furman, W. (1996). The measurement of friendship perceptions: Conceptual and methodological issues. In W. M. Bukowski, A. F. Newcomp, & W. W. Hartup (Eds.). *The company they keep* (pp. 41-65). New York: Cambridge University Press.
- Furman, W., & Buhrmester, D. (1985). Children`s perceptions of the personal relationships in their social networks. *Developmental Psychology, 21*. 1016-1024.
- Furman, W., & Rose, A. (2015). Friendships, romantic relationships, and other dyadic peer relationships in childhood and adolescence: A unified relational perspective. In R. Lerner (Series Ed.) and M. E. Lamb & C. G. Coll (Volume Eds.), *The handbook of child psychology and developmental science* (Seventh Edition); Vol. 3, Social and emotional development. Hoboken, NJ US: John Wiley & Sons Inc.
- Garcia, M. M., Shaw, D. S., Winslow, E. B., & Yaggi, K. E. (2000). Destructive sibling conflict and the development of conduct problems in young boys. *Developmental Psychology, 36*, 44-53.
- Gass, K., Jenkins, J., & Dunn, J. (2007). Are sibling relationships protective? A longitudinal study. *Journal of Child Psychology and Psychiatry, 48*, 167-175.
- Goldsmith, H. (1991). A zygosity questionnaire for young twins: A research note. *Behavior genetics, 21*(3), 257-269.
- Hay, D. A., & Preedy, P. (2006). Meeting the educational needs of multiple birth children. *Early Human Development, 82*, 397-403.
- Jackson, Y., & Warren, J. S. (2000). Family, School, and Community Appraisal, Social Support, and Life Events: Predicting Outcome Behavior in School-Age Children. *Child Development, 71*(5), 1441-1457.

- Jenkins, J. M., & Smith, M. A. (1990). Factors protecting children living in disharmonious homes: Maternal reports. *Journal of the American Academy of Child & Adolescent Psychiatry*, 29, 60-69.
- Koch, H. L. (1966). *Twins and twin relations*. University of Chicago Press. Chicago.
- Ladd, G. W. (1983). Social networks of popular, average and rejected children in school settings. *Merrill-Palmer Quarterly*, 29, 283-307.
- Lamarche, V., Brendgen, M., Boivin, M., Vitaro, F., Pérusse, D., & Dionne, G. (2006). Do friendship and sibling relationships provide protection against peer victimization in a similar way? *Social Development*, 15, 373-393.
- Little, T. D., Cunningham, W. A., Shahar, G., & Widaman, K. F. (2002). To parcel or not to parcel: Exploring the question, weighing the merits. *Structural equation modeling*, 9(2), 151-173.
- Liu, Y.-L. (2008). An examination of three models of the relationships between parental attachments and adolescents' social functioning and depressive symptoms. *Journal of Youth and Adolescence*, 37, 941-952. doi: 10.1007/s10964-006-9147-1
- Lockwood, R. L., Kitzmann, K. M., & Cohen, R. (2001). The impact of sibling warmth and conflict on children's social competence with peers. *Child Study Journal*, 31, 47-69.
- Magnusson, P. K., Almqvist, C., Rahman, I., Ganna, A., Viktorin, A., Walum, H., ... & Lichtenstein, P. (2013). The Swedish Twin Registry: establishment of a biobank and other recent developments. *Twin Research and Human Genetics*, 16(01), 317-329.
- Martin, J.A., Hamilton, B.E., & Osterman, J.K., (2012). Three decades of twin births in the United States 1980-2009. *NCHS Data Brief*, 80.
- McCoy, J. K., Brody, G. H. & Stoneman, Z. (1994). Longitudinal analyses of sibling relationships as mediators of the link between family processes and youths' best friendships. *Family Relations*, 43, 400-08.

- McGuire, S., & Segal, N.L. (2013). Peer network overlap in twin, sibling and friend dyads. *Child Development, 84*, 500-511.
- Modry-Mandell, K., Gamble, W., & Taylor, A. (2007). Family emotional climate and sibling relationship quality: Influences on behavioral problems and adaptation in preschool-aged children. *Journal of Child and Family Studies, 16* (1), 59-71. doi: 10.1007/s10826-006-9068-3.
- Moilanen, I., Linna, S., Ebeling, H., Kumpulainen, K., Tamminen, T., Piha, J., et al. (1999). Are twins' behavioural/emotional problems different from singletons'? *European Child & Adolescent Psychiatry 8*, 62-67. doi: 10.1007/pl00010702
- Muthén, L. K., & Muthén, B. O. (2007). *Mplus User's Guide* (5th ed.). Los Angeles: Muthén & Muthén.
- Nozaki, M., Fujisawa, K. K., Ando, J., & Hasegawa, T. (2012). The effects of sibling relationships on social adjustment among Japanese twins compared with singletons. *Twin Research and Human Genetics, 15*, 727-736.
- Patterson, G. R. (1984). Siblings: Fellow travelers in coercive family processes. *Advances in the Study of Aggression, 1*, 173-214.
- Price, J. M. (1996). Friendships of maltreated children and adolescents: Contexts for expressing and modifying relationship history. In W. M. Bukowski, A. F. Newcomb, & W. W. Hartup (Eds.), *The company they keep: Friendship in childhood and adolescence*. Cambridge, UK: Cambridge University Press.
- Satorra, A. (2000). Scaled and adjusted restricted tests in multi-sample analysis of moment structures. In Heijmans, R.D.H., Pollock, D.S.G. & Satorra, A. (eds.), *Innovations in multivariate statistical analysis. A Festschrift for Heinz Neudecker* (pp.233-247). London: Kluwer Academic Publishers.

- Segal, L. N., McGuire, S. A., Miller, S. A., & Havlena, J. (2008). Tacit coordination in monozygotic twins, dizygotic twins and virtual twins: Effects and implications of genetic relatedness. *Personality and Individual Differences, 45*, 607-612.
- Spitz, E., Moutier, R., Reed, T., Busnel, M. C., Marchaland, C., Roubertoux, P. L., & Carlier, M. (1996). Comparative diagnoses of twin zygosity by SSLP variant analysis, questionnaire, and dermatoglyphic analysis. *Behavior Genetics, 26*(1), 55-63.
- Stocker, C. M. (1994). Children's Perceptions of Relationships with Siblings, Friends, and Mothers: Compensatory Processes and Links with Adjustment. *Journal of Child Psychology and Psychiatry, 35*(8), 1447-1459.
- Stocker, C., & Dunn J. (1990). Sibling relationships in childhood: links with friendships and peer relationships. *British Journal of Developmental Psychology, 8*, 227-244.
- Stormshak, E. A., Bellanti, C. J., & Bierman, K. L. (1996). The quality of sibling relationships and the development of social competence and behavioral control in aggressive children. *Developmental Psychology, 32*, 79-89.
- Stice, E., Ragan, J., & Randall, P. (2004). Prospective Relations Between Social Support and Depression: Differential Direction of Effects for Parent and Peer Support? *Journal of Abnormal Psychology, 113*(1), 155-159.
- Sullivan, H. S. (1953). *An interpersonal theory of psychiatry*. New York: Norton.
- Thorpe, K. (2003). Twins and Friendship. *Twin Research and Human Genetics, 6*(6), 532-535.
- Thorpe, K., & Danby, S. (2006). Compromised or competent: Analysing twin children's social worlds. *Twin Research and Human Genetics, 9*, 90-94.
- Thorpe, K., & Gardner, K. (2006). Twins and their friendships: differences between monozygotic, dizygotic same-sex and dizygotic mixed-sex pairs. *Twin Research and Human Genetics, 9*, 155-164.
- Williams, R. L., (2000). A note on robust variance estimation for cluster-correlated data. *Biometrics, 56*, 645-646.

Zahn-Waxler, C., Robinson, J. L., & Emde, R. N. (1992). The development of empathy in twins.
Developmental Psychopathology, 28, 1038-1047.

Table 1a. Bivariate Correlation Between Positive Relationship Features (Parcels) for Friendship Quality and Twin Relationship Quality

Measure	Sex	Zygoty	1	2	3	4	5	6	7	8
1.Egalitarian friendship Q 13	.25	.02	1							
2.Supportive friendship Q 13	.40	.04	.66	1						
3.Egalitarian twinship Q 13	.24	.01	.53	.36	1					
4.Supportive twinship Q 13	.35	-.04	.40	.52	.67	1				
5.Egalitarian friendship Q 14	.44	-.02	.41	.62	.32	-.10	1			
6.Supportive friendship Q 14	.26	-.08	.40	.37	.37	.18	.67	1		
7.Egalitarian twinship Q 14	.35	-.13	.25	.31	.48	.65	.50	.43	1	
8.Supportive twinship Q 14	.22	-.05	.31	.24	.59	.54	.40	.56	.76	1
Mean			11.5	9.8	10.6	8.9	9.6	11.0	8.8	9.9
SD			2.6	3.5	3.2	3.9	3.6	2.7	3.9	3.4

Note: * Sex was coded as '0' representing males, and '1' representing females.; ***Bold* = significant at $p < 0.01$

Table 1b. Bivariate Correlation Between Negative Relationship Features (Parcels) for Friendship Quality and Twin Relationship Quality

Measures	Sex	Zygotity	1	2	3	4	5	6	7	8
1. Angry friendship Q 13	-.10	.01	1							
2. Disagree friendship Q 13	-.07	.00	.63	1						
3. Angry twinship Q 13	-.09	-.05	.22	.16	1					
4. Disagree twinship Q13	-.10	-.08	.17	.23	.75	1				
5. Angry friendship Q 14	-.03	.01	.32	.26	.15	.16	1			
6. Disagree friendship Q 14	-.07	.00	.36	.41	.13	.16	.64	1		
7. Angry twinship Q 14	-.02	-.05	.19	.17	.58	.56	.29	.24	1	
8 Disagree Q twinship 14	-.02	-.08	.17	.18	.51	.57	.24	.25	.78	1
Mean			3.0	3.5	5.1	6.1	3.1	3.7	4.8	5.8
SD			1.2	1.4	1.9	2.1	1.1	1.3	1.9	2.0

Note: * Sex was coded as '0' representing males, and '1' representing females.; ***Bold = significant at p < 0.01*

Table 2a. Model Fit for Latent Factor Structure Equality Tests, Using Chi-square Difference Tests Across Sex, Positive Quality

	χ^2 (df)	co	CFI	TLI	REMSA	<i>p</i>	S-b χ^2	df	cd
Comparison	142.04(76)	1.1	0.96	0.94	.079	0.00			
Model A	144.84(80)	1.09	0.96	0.95	.077	0.00	1.29	4	0.82
Model B	148.51(80)	1.12	0.96	0.95	.079	0.00	6.68	4	1.42
Model C	141.48(80)	1.09	0.96	0.95	.075	0.00	-3.15	4	0.82

Note: Comparison: comparison model with all factor loadings constrained and latent covariance free to vary across groups. Model A: group invariance of the stability paths of positive friendship quality and positive twin relationship quality over time; Model B: group invariance of the concurrent associations between friendship and twin relationship quality within time; Model C: group invariance of the cross-lagged associations between friendship and twin relationship quality across time. χ^2 = Chi-square; df= degrees of freedom; co= scaling correction factor; CFI = comparative fit index; TLI Tucker Lewis Index; RMSEA= root mean squared estimate of approximation. S-b χ^2 = Satorra-bentler chi-square difference tests; cd= difference tests scaling correction.

Table 2b. Model Fit for Latent Factor Structure Equality Tests, Using Chi-square Difference Tests Across Zygosity, Positive Quality

	χ^2 (df)	co	CFI	TLI	REMSA	<i>p</i>	S-b χ^2	df	cd
Comparison	142.04(76)	1.1	0.96	0.94	.079	0.00			
Model A	146.09 (80)	1.1	0.96	0.95	.077	0.00	3.79	4	1.02
Model B	143.08 (80)	1.12	0.96	0.95	.076	0.00	4.9	4	3.02
Model C	143.51 (80)	1.11	0.96	0.95	.076	0.00	3.02	4	1.22

Note: Comparison: comparison model with all factor loadings constrained and latent covariance free to vary across groups. Model A: group invariance of the stability paths of positive friendship quality and positive twin relationship quality over time; Model B: group invariance of the concurrent associations between friendship and twin relationship quality within time; Model C: group invariance of the cross-lagged associations between friendship and twin relationship quality across time. χ^2 = Chi-square; df= degrees of freedom; co= scaling correction factor; CFI = comparative fit index; TLI Tucker Lewis Index; RMSEA= root mean squared estimate of approximation. S-b χ^2 = Satorra-Bentler chi-square difference tests; cd= difference tests scaling correction.

Table 3a. Model Fit for Latent Factor Structure Equality Tests, Using Chi-square Difference Tests Across Sex, Negative Quality

	χ^2 (df)	co	CFI	TLI	REMSA	<i>p</i>	S-b χ^2	df	cd
Comparison	124.19 (84)	1.19	.98	.97	.059	0.00			
Model A	124.2 (88)	1.19	.98	.97	.055	0.00	0.88	4	1.4
Model B	128,32 (88)	1.17	.98	.97	.058	0.00	0.75	4	3.11
Model C	132.58 (88)	1.16	.97	.97	.061	0.00	6.26	4	0.53

Note: Comparison: comparison model with all factor loadings constrained and latent covariance free to vary across groups. Model A: group invariance of the stability paths of positive friendship quality and positive twin relationship quality over time; Model B: group invariance of the concurrent associations between friendship and twin relationship quality within time; Model C: group invariance of the cross-lagged associations between friendship and twin relationship quality across time. χ^2 = Chi-square; df= degrees of freedom; co= scaling correction factor; CFI = comparative fit index; TLI Tucker Lewis Index; RMSEA= root mean squared estimate of approximation. S-b χ^2 = Satorra-Bentler chi-square difference tests; cd= difference tests scaling correction.

Table 3b. Model Fit for Equality Tests, Using Chi-square Difference Tests Across Zygosity, Negative Quality

	χ^2 (df)	co	CFI	TLI	REMSA	<i>p</i>	S-b χ^2	df	cd
Comparison	124.19 (84)	1.19	.98	.97	.059	0.00			
Model A	123.54 (88)	1.20	.98	.97	.054	0.00	0.32	4	1.4
Model B	132.34 (88)	1.18	.97	.97	.060	0.00	8.63	4	0.92
Model C	130.95 (88)	1.17	.97	.97	.060	0.00	7.23	4	0.75

Note: Comparison: comparison model with all factor loadings constrained and latent covariance free to vary across groups. Model A: group invariance of the stability paths of positive friendship quality and positive twin relationship quality over time; Model B: group invariance of the concurrent associations between friendship and twin relationship quality within time; Model C: group invariance of the cross-lagged associations between friendship and twin relationship quality across time. χ^2 = Chi-square; df= degrees of freedom; co= scaling correction factor; CFI = comparative fit index; TLI Tucker Lewis Index; RMSEA= root mean squared estimate of approximation. S-b χ^2 = Satorra-Bentler chi-square difference tests; cd= difference tests scaling correction.

Figure Legends:

Figure 1a: Positive Quality Estimates From the Final Constrained Model

Note: Model estimates are unstandardized. x_1 and x_3 , and y_1 and y_3 represent the egalitarian features, and x_2 , x_4 and y_2 , y_4 represent the supportive relationship features. Residual correlations were added between x_1 and x_3 , between x_1 and y_1 ; x_3 and y_3 ; y_1 and y_3 . CI is presented in brackets [95%]. Dashed lines are non-significant; full-lines are significant at $p < 0.001$.

Figure 1b: Negative Quality Estimates From the Final Constrained Model

Note: Model estimates are unstandardized. x_1 and x_3 , and y_1 and y_3 represent the angry features, and x_2 , x_4 and y_2 , y_4 represent disagreement relationship features, Residual correlations were added between x_2 and y_2 , between x_1 and x_4 and y_4 . CI is presented in brackets [95%]. Dashed lines are non-significant; full-lines are significant at $p < 0.001$.

Acknowledgements:

Funding for this study was provided by the Social Sciences and Humanities Research Council of Canada. We thank Jocelyn Malo and Marie-Elyse Bertrand for coordinating the data collection and H el ene Paradis for data management and preparation. We also thank the twins and their families for participating in this study.

Figure 1a

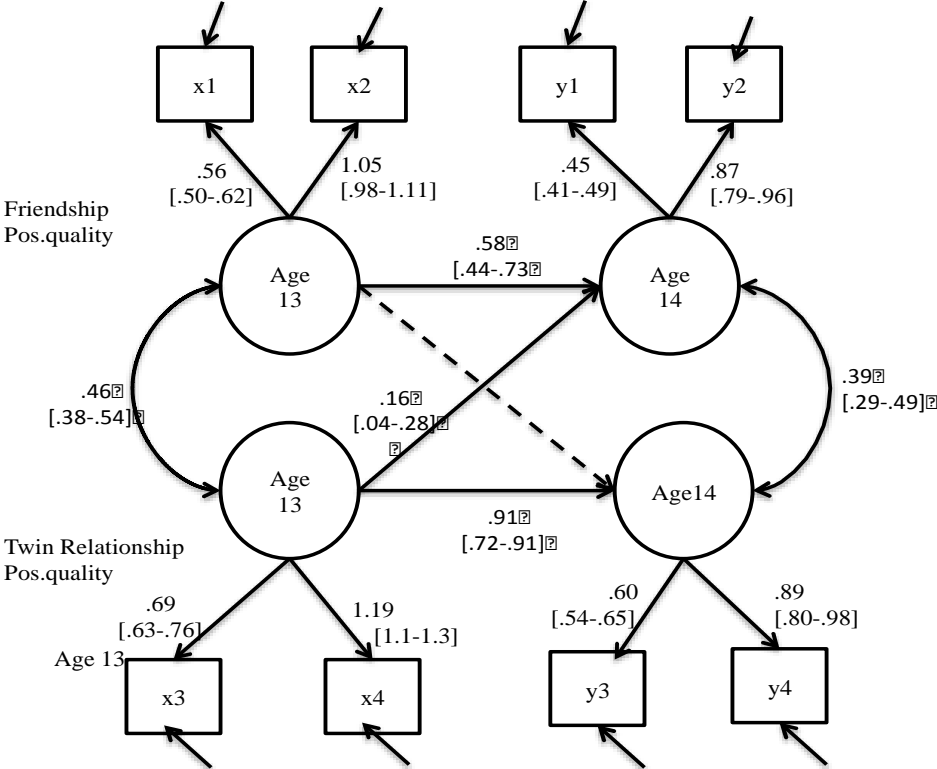

Figure 1b

