

Université de Montréal

**Substituted Azetidine-2-carboxylic Acid Synthesis**

Par

**Zohreh Sajjadi Hashemi**

Département de Chimie  
Faculté des Arts et Sciences

Mémoire présenté à la Faculté des Études Supérieures  
En vue de l'obtention du grade de  
Maître ès Sciences (M.Sc.)  
En Chimie

Avril, 2006

©Zohreh Sajjadi, 2006





Direction des bibliothèques

## AVIS

L'auteur a autorisé l'Université de Montréal à reproduire et diffuser, en totalité ou en partie, par quelque moyen que ce soit et sur quelque support que ce soit, et exclusivement à des fins non lucratives d'enseignement et de recherche, des copies de ce mémoire ou de cette thèse.

L'auteur et les coauteurs le cas échéant conservent la propriété du droit d'auteur et des droits moraux qui protègent ce document. Ni la thèse ou le mémoire, ni des extraits substantiels de ce document, ne doivent être imprimés ou autrement reproduits sans l'autorisation de l'auteur.

Afin de se conformer à la Loi canadienne sur la protection des renseignements personnels, quelques formulaires secondaires, coordonnées ou signatures intégrées au texte ont pu être enlevés de ce document. Bien que cela ait pu affecter la pagination, il n'y a aucun contenu manquant.

## NOTICE

The author of this thesis or dissertation has granted a nonexclusive license allowing Université de Montréal to reproduce and publish the document, in part or in whole, and in any format, solely for noncommercial educational and research purposes.

The author and co-authors if applicable retain copyright ownership and moral rights in this document. Neither the whole thesis or dissertation, nor substantial extracts from it, may be printed or otherwise reproduced without the author's permission.

In compliance with the Canadian Privacy Act some supporting forms, contact information or signatures may have been removed from the document. While this may affect the document page count, it does not represent any loss of content from the document.

**Université de Montréal**  
**Faculté des Études Supérieures**

**Ce mémoire intitulé:**

**Substituted Azetidine-2-carboxylic Acid Synthesis**

Présenté par

**Zohreh Sajjadi Hashemi**

**A été évalué par un jury compose des personnes suivantes**

Président-rapporteur

Directeur de Recherche

Membre du Jury

Professeur GIASSON, RICHARD

Professeur LUBELL, WILLIAM D.

Professeur COLLINS, SHAWN

Mémoire accepté le:

## Acknowledgements

I would like to express special thanks to my supervisor, Prof. William D. Lubell for giving me the opportunity to work in his group and for his continuous guidance, advice and encouragement throughout this research.

I would like to thank all present and past members of Lubell group for their assistance and friendship. My thanks go to my colleagues, Aurélie Dörr, Dr. Susan Seaman, Dr. Teresa Lama, Dr. Gil Fridkin, Benoit Jolicoeur, Nicolas Genest, Simon Surprenant, Yann Brouillette, Carine Bourguet, Wajih Bin Tahar, Hassan Iden. Special thanks go to Dr. John Blankenship for helpful discussion on my project. I appreciate the help of Fabrice Galaud for translation the Sommaire of my thesis.

I appreciate the help of Mr. Dalbir Sekhon with LC/MS experiments, Dr. Alexandra Frutos and Mrs. Karine Venne for mass spectral analysis, Mrs. Mildred Bien-Aimé and Mrs. Lyne Lurin, Secretary of the Chemistry Department.

And of course, I am truly grateful to have the love and the patience from my husband and my children throughout these years. Their support and trust made it possible the completion of this work.

## Abstract

Azetidine-2-carboxylic acid (Aze) is the four-member homologue of proline. Aze and substituted Aze are constituents of natural and pharmacological products and biologically active compounds. The preparation of substituted Aze analogues is, however, a challenge for which few routes have been reported. In studying general methodology for the preparation of Aze derivatives, we have now focused on developing new routes for the synthesis of Aze analogues with substituents at the 3- and 4-position. These orthogonally protected amino acid-Aze chimeras have been designed to serve as tools for studying the influence of conformation on peptide activity.

In chapter 2, the synthesis of azetidine 2-carboxylic acid (Aze) analogs possessing various heteroatomic side chains at the 3-position is presented and features modification of 1-PhF-3-allyl-Aze *tert*-butyl ester (2*S*,3*S*)-**2.1** (PhF = 9-(9-phenylfluorenyl)). 3-Allyl-Aze **2.1** was synthesized from a sequence commencing with regioselective allylation of  $\alpha$ -*tert*-butyl  $\beta$ -methyl *N*-(PhF)aspartate **2.13**, followed by selective  $\omega$ -carboxylate reduction, tosylation and intramolecular *N*-alkylation. Removal of the PhF group and olefin reduction by hydrogenation followed by Fmoc protection produced nor-Leucine-Aze chimera **2.2**. Regioselective olefin hydroboration of (2*S*,3*S*)-**2.1** produced primary alcohol **2.23**, which was protected as a silyl ether, hydrogenated and *N*-protected to give 1-Fmoc-3-hydroxypropyl-Aze **2.26**. Enantiopure (2*S*,3*S*)-3-(3-azidopropyl)-1-Fmoc-azetidine-2-carboxylic acid *tert*-butyl ester **2.3** was prepared as a Lys-Aze chimera by activation of 3-hydroxypropyl-Aze **2.26** as a methanesulfonate and displacement with sodium azide. Moreover, orthogonally protected azetidine dicarboxylic acid **2.4** was synthesized as an  $\alpha$ -aminoadipate-Aze chimera by oxidation of alcohol **2.26**.

Chapter 3, a study to develop new methodology for the preparation of 4-substituted Aze analogues was performed. Three approaches were examined. In the first approach novel 2,4-disubstituted azetidine-3-one **3.43** was synthesized for the first time by employing an intramolecular metal carbenoid N-H insertion of  $\alpha$ -diazo  $\beta$ -ketophosphonate **3.40** which was prepared from L-serine as a chiral educt. In the second approach, a  $S_N2'$  strategy has been used to synthesize 4-vinyl Aze analogues. For example, diastereomeric mixture of 4-propenyl *N*-(PhF)Aze **3.48** was synthesized by the Horner-Wadsworth-Emmons (HWE) olefination of  $\alpha$ -*tert*-butyl-*N*-(PhF)aspartate  $\beta$ -aldehyde **3.42** with  $\beta$ -keto phosphonate **3.44**, followed by reduction of the resulting  $\alpha,\beta$ -unsaturated ketone **3.45**, activation of the corresponding alcohol **3.46** as a tosylate **3.47** and intramolecular  $S_N2'$  reaction. In an attempt to synthesize 4-vinyl *N*-(PhF) Aze **3.59**, pipercolate **3.58** was formed instead of 4-substituted azetidine **3.59** during the  $S_N2'$  reaction in the presence of DMAP. Diastereomeric mixtures of 4-vinyl Aze **3.65** were produced in 11 steps from aspartic acid by application of allylglycine methyl ester **3.63** in a cross-metathesis/ intramolecular  $S_N2'$  *N*-alkylation strategy. The novel 4-substituted Aze analogues offer potential to serve as precursors for making azabicyclo[4.2.0] and [5.2.0]alkane amino acids, such as **3.11** and **3.13**. Although an alternative approach failed to produce 4-substituted Aze by intramolecular ring opening of an epoxide by nucleophilic attack of a  $\beta$ -amine, new amino epoxides **3.70** and **3.74** were synthesized for the first time from L-Asp as an inexpensive chiral educt. These amino epoxides may serve as intermediates for synthesis of other functionalized compounds.

We have developed new syntheses of amino acid analogues including enantiopure 3-substituted azetidine-2-carboxylic acids **2.2**, **2.3** and **2.4**, for exploring structure-activity

relationships of various biologically active peptides. Also, we have developed new methodologies for synthesizing 4-substituted Aze analogues **3.43**, **3.48**, **3.65**, which may enable syntheses of novel azabicyclo[X.Y.0]alkane derivatives. In summary, this thesis has provided new methodology for making azetidines to explore their conformational and biological properties.

**Key words:** azetidine 2-carboxylic acid; azetidines; amino acid; chimera; heterocycle; peptide synthesis



## Sommaire

L'acide 2-azétidine carboxylique (Aze) est un homologue à quatre chaînons de la proline. Aze et Aze substitué sont des constituants de produits naturels et pharmacologiques ainsi que de composés biologiquement actifs. La préparation des analogues d'Aze substitués est, cependant, un défi pour lequel peu de voies de synthèse ont été reportées. En étudiant une méthodologie générale pour la préparation des dérivés d'Aze, nous nous sommes concentrés à développer de nouvelles voies de synthèse pour les analogues d'Aze substitués en position 3 et 4. Ces chimères d'Aze ont été élaborées pour servir d'outil dans l'étude de l'influence de la conformation dans l'activité des peptides.

Dans le chapitre 2, la synthèse d'analogues de l'acide 2-azétidine carboxylique (Aze) possédant différents hétéroatomes sur les chaînes latérales à la position 3 est présentée en plus de la modification de l'ester *tert*-butylique du 1-PhF-3-allyl-Aze (*2S,3S*)-**2.1** (PhF = 9-(9-phénylfluorényle)). Le 3-allyl Aze **2.1** a été synthétisé tout d'abord avec une allylation régiosélective du diester  $\alpha$ -*tert*-butylique  $\beta$ -méthylique de l'acide *N*-(PhF)aspartique **2.13**, suivie par une réduction sélective du  $\omega$ -carboxylate, tosylation et *N*-alkylation intramoléculaire. Le clivage du groupement PhF et la réduction de l'oléfine par hydrogénation suivis par une protection avec un groupement Fmoc ont produit la chimère norleucine-Aze **2.2**. Une hydroboration régiosélective de l'oléfine (*2S,3S*)-**2.1** a produit l'alcool primaire **2.23**, qui après protection par un groupement éther de silyle, hydrogénation et protection de l'amine a donné le 1-Fmoc-3-hydroxypropyle-Aze **2.26**. L'ester *tert*-butylique énantio pur de l'acide (*2S,3S*)-3-(3-azidopropyle)-1-Fmoc-azétidine-2-carboxylique **2.3** a été préparé comme une chimère de la Lys-Aze par activation du 3-hydroxypropyl-Aze **2.26** comme un méthanesulfonate et déplacement avec un azidure de

sodium. De plus, l'acide dicarboxylique **2.4** de l'azétidine protégée orthogonalement a été synthétisé comme une chimère du  $\alpha$ -aminoadipate Aze par oxydation de l'alcool **2.26**.

Dans le chapitre 3, une étude pour développer une nouvelle méthodologie pour la préparation des analogues de l'Aze substitué en position 4 a été réalisée. Trois approches ont été examinées. Dans une première approche, l'azétidine-3-one 2,4-disubstituée **3.43** a été synthétisée pour la première fois en employant une insertion intramoléculaire d'un carbénoïde métallique N-H du  $\alpha$ -diazo  $\beta$ -cétophosphonate **3.40** qui a été préparé à partir de la L-sérine comme entité chirale. Dans une seconde approche, une stratégie  $S_N2'$  a été utilisée pour la synthèse d'analogues 4-vinyle Aze. Par exemple, un mélange diastéréomérique du 4-propényle *N*-(PhF)Aze **3.48** a été synthétisé par oléfination d'Horner-Wadsworth-Emmons (HWE) du  $\alpha$ -*tert*-butyl-*N*-(PhF)aspartate  $\beta$ -aldéhyde **3.42** avec le  $\beta$ -cétophosphonate **3.44**, suivie par une réduction de la cétone  $\alpha,\beta$ -insaturée résultante **3.45**, activation de l'alcool correspondant **3.46** comme un tosylate **3.47** et une réaction intramoléculaire  $S_N2'$ . Dans une tentative de synthèse du 4-vinyl *N*-(PhF) Aze **3.59**, le pipécolate **3.58** a été formé au lieu de l'azétidine 4-substituée **3.59** durant la réaction  $S_N2'$  en présence de DMAP. Un mélange diastéréomérique du 4-vinyle Aze **3.65** a été produit en 11 étapes à partir de l'acide aspartique par application de l'ester méthylique de l'allylglycine **3.63** dans une stratégie de métathèse croisée / *N*-alkylation intramoléculaire  $S_N2'$ . Ces nouveaux analogues de l'Aze substitué en position 4 peuvent servir comme précurseurs dans la synthèse des acides aminés [4.2.0] et [5.2.0] azabicycliques, tels que **3.11** et **3.13**. Bien qu'une approche alternative pour former l'Aze 4-substituée par ouverture intramoléculaire d'un époxyde par attaque nucléophile d'une  $\beta$ -amine ait échoué, de nouveaux amino époxydes **3.70** et **3.74** ont été synthétisés à partir du

L-Asp. Ces amino époxydes peuvent servir d'intermédiaires dans la synthèse d'autres composés fonctionnalisés.

Nous avons développé de nouvelles synthèses d'analogues d'acides aminés dont les acides 3-substitués azétidine-2-carboxyliques **2.2**, **2.3**, **2.4**, pour explorer la relation structure-activité de différents peptides biologiquement actifs. Aussi, nous avons développé de nouvelles stratégies pour synthétiser des analogues de l'Aze 4-substitués **3.43**, **3.48**, **3.65**, qui devraient être utiles dans la synthèse de nouveaux dérivés de  $\beta$ -lactame azabicyclique[X.Y.0]alcane.

**Mots Clés:** acide 2-azétidine carboxylique; azétidines; acides aminés; chimères; hétérocycles; synthèse peptidique

## Table of contents

<b>Abstract</b>	i
<b>Sommaire</b>	iv
<b>Table of contents</b>	vii
<b>List of Figures</b>	xv
<b>List of Tables</b>	xvi
<b>List of Schemes</b>	xvi
<b>Abbreviations</b>	xx

## Chapter 1: Introduction

<b>1.1 Peptide and peptide mimicry</b>	2
1.1.1 Peptides and proteins	2
1.1.2 Structure of peptides	3
1.1.3 The drawbacks of the use of peptides	5
1.1.4 Peptide mimicry and its importance	5
1.1.5 The importance of peptidomimetics in drugs	5
1.1.6 Different approaches for peptide mimicry	6
<b>1.2 Cyclic amino acid chimeras</b>	
1.2.1 Proline and pipercolic acids as higher homologues of azetidine-2-carboxylic acid	12

<b>1.3</b>	<b>Azetidine-2-carboxylic acids (Aze) and their applications</b>	
1.3.1	Applications of Azetidine-2-carboxylic acids	14
1.3.2	Synthesis of Azetidine-2-carboxylic acids	16
1.3.2.1	Synthesis of DL and D-Aze starting from 2-bromo or 2-chloro-4-aminobutanoic acid	16
1.3.2.2	Synthesis of Aze starting from $\gamma$ -butyrolactone	17
1.3.2.3	Synthesis of L-Aze starting from ( <i>S</i> )- <i>N</i> -toluenesulfonyl-homoserine lactone	18
1.3.2.4	Asymmetric synthesis of (+) - and (-)-Aze from $\alpha$ -methylbenzyl amine as the source of chirality	19
<b>1.4</b>	<b>Substituted azetidine-2-carboxylic acids</b>	
<b>1.4.1</b>	<b>3-Substituted azetidine-2-carboxylic acids</b>	<b>21</b>
1.4.1.1	Synthesis of Phe-Aze, Nal-Aze, Leu-Aze chimeras	21
1.4.1.2	Synthesis of the Glu-Aze chimeras, (-)- <i>trans</i> -2 - carboxyazetidine-3-acetic acid ( <i>t</i> -CAA)	22
1.4.1.3	Synthesis of ( <i>2R,3S</i> )- and ( <i>2S,3R</i> ) azetidine-2-carboxylic acids <b>1.39</b>	23
1.4.1.4	Synthesis of the Val-Aze chimera, 3,3-dimethyl-azetidine-2-carboxylic acid	24
1.4.1.5	3-Phenyl Aze from $\beta$ -amino alcohol <b>1.44</b>	25
1.4.1.6	Asymmetric synthesis of 3-substituted Aze employing SAMP/RAMP methodology	26

<b>1.4.2</b>	<b>Synthesis of 4-substituted azetidine-2-carboxylic acids</b>	
1.4.2.1	Synthesis of 4-trifluoromethylated azetidine-2-carboxylic acid	28
1.4.2.2	Selective azetidine formation via Pd-catalyzed cyclizations of allene-substituted amines and amino acids	29
1.4.2.3	Synthesis of azetidine-2,4-dicarboxylic acid	31
1.4.2.4	Synthesis of 4-substituted Aze via Wittig reaction of monocyclic lactams	32
<b>1.5</b>	<b>References</b>	<b>34</b>

## **Chapter 2: Synthesis of 3-substituted azetidine-2-carboxylic acid**

**Article:** Amino acid-azetidine chimeras: synthesis of enantiopure 3-substituted azetidine-2-carboxylic acids

<b>2.1</b>	<b>Abstract</b>	<b>42</b>
<b>2.2</b>	<b>Introduction</b>	<b>43</b>
<b>2.3</b>	<b>Results and discussion</b>	<b>48</b>
<b>2.4</b>	<b>Conclusion</b>	<b>55</b>
<b>2.5</b>	<b>Experimental section</b>	<b>55</b>
<b>2.6</b>	<b>Acknowledgement</b>	<b>68</b>
<b>2.7</b>	<b>References</b>	<b>69</b>

## Chapter 3: Study of the synthesis 4-substituted azetidine-2-carboxylic acid

<b>3.1</b>	<b>Introduction</b>	76
3.1.1	Objectives	78
<b>3.2</b>	<b>Results and discussions</b>	79
<b>3.2.1</b>	<b>Study of the synthesis of 4-substituted azetidine-3-one by Carbenoid insertion into the <math>\gamma</math>-amino N-H bond using <math>\alpha</math>-diazo <math>\beta</math>-diketone or <math>\alpha</math>-diazo <math>\beta</math>-ketoester substrates</b>	79
3.2.1.1	Attempts for the synthesis of 4-substituted azetidine-3-one <b>3.30</b> via diazo insertion using diazomethane	82
3.2.1.2	Attempts to the synthesis of 4-substituted azetidine-3-one <b>3.34</b> via diazo insertion using ethyldiazoacetate	83
3.2.1.3	Synthesis of 4-substituted azetidine-3-ones <b>3.43</b> using metal Carbenoid N-H insertion and $\gamma$ -amino $\beta$ -ketophosphonate <b>3.39</b>	84
<b>3.2.2</b>	<b>Synthesis of 4-substituted Aze via <math>S_N2'</math></b>	
3.2.2.1	Synthesis of 4-propenyl Aze <b>3.48</b> from allylic alcohol <b>3.46</b> by $S_N2'$ displacement	87
3.2.2.2	Attempted synthesis of 4-substituted Aze <b>3.53</b> from allylic alcohol <b>3.51</b> by $S_N2'$ reaction	89
3.2.2.3	Attempted synthesis of 4-vinyl Aze <b>3.59</b> from allylic alcohol <b>3.55</b>	90

3.2.2.4	Synthesis of 4-vinyl Aze <b>3.65</b> via $S_N2'$ reaction of allylic chloride <b>3.64</b>	92
<b>3.2.3</b>	<b>Attempts to synthesis of 4-substituted Aze via intramolecular nucleophilic ring opening of an epoxide</b>	
3.2.3.1	Synthesis of epoxide <b>3.71</b> from L-aspartic acid	96
3.2.3.2	Synthesis of epoxide <b>3.74</b> from L-aspartic acid	96
<b>3.3</b>	<b>Conclusion</b>	98
<b>3.4</b>	<b>Experimental Procedures</b>	
3.4.1	<b>General Information</b>	100
3.4.2	<b>Study of Carbenoid insertion into the <math>\gamma</math>-amino NH bond using diazo <math>\beta</math>-diketone and <math>\alpha</math>-diazo <math>\beta</math>-ketoester substrates</b>	101
	(2 <i>S</i> )- <i>N</i> -Boc serine ( <b>3.25</b> )	101
	(2 <i>S</i> )-2- <i>tert</i> -Butoxycarbonylamino-3-( <i>tert</i> -butyl-diphenyl silanyloxy) Propionic Acid ( <b>3.27</b> )	101
	(2 <i>S</i> )-2- <i>tert</i> -Butoxycarbonylamino-3-( <i>tert</i> -butyl-diphenyl-silanyloxy)- Propionic Acid Methyl Ester ( <b>3.38</b> )	102
	(3 <i>S</i> )-[3- <i>tert</i> -Butoxycarbonylamino-4-( <i>tert</i> -butyl-diphenyl-silanyloxy)-2-oxo-butyl]-Phosphonic Acid Dimethyl Ester ( <b>3.39</b> )	103
	(3 <i>S</i> )-[3- <i>tert</i> -Butoxycarbonylamino-4-( <i>tert</i> -butyl-diphenyl-silanyloxy)-1-diazo-2-oxo-butyl]-Phosphonic Acid Dimethyl Ester ( <b>3.40</b> )	104



(2*S*)-*N*-(Boc)-2-(*tert*-Butyl-diphenyl-silanyloxymethyl)-4-(dimethoxyphosphonyl)-3-Azetidinone (3.41) 105

(2*R*,4*R*)-2-[3-*tert*-Butoxycarbonyl-3-(9-phenyl-9H-fluoren-9-ylamino)-propylidene]-4-(*tert*-butyl-diphenyl-silanyloxymethyl)-3-Azetidinone-1-Carboxylic Acid *tert*-Butyl Ester (3.43) 106

### 3.4.3 Synthesis of 4-substituted Aze via $S_N2'$

#### 3.4.3.1 Synthesis of 4-propenyl Aze 3.48 from allylic alcohol 3.46 by $S_N2'$ displacement

(2-Oxo-propyl)-Phosphonic Acid Dimethyl Ester (3.44) 108

(2*S*)-6-Oxo-2-(9-phenyl-9H-fluoren-9-ylamino)-hept-4-enoic Acid *tert*-Butyl Ester (3.45) 108

(2*S*)-6-Hydroxy-2-(9-phenyl-9H-fluoren-9-ylamino)-hept-4-enoic Acid *tert*-Butyl Ester (3.46) 109

(2*S*)-2-(9-Phenyl-9H-fluoren-9-ylamino)-6-(toluene-4-sulfonyloxy)-hept-4-enoic Acid *tert*-Butyl Ester (3.47) and *N*-(PhF) 3-Propenyl Azetidine 2-*tert*-Butyl Ester (3.48) 110

4-Propyl-Azetidine-2-Carboxylic Acid *tert*-Butyl Ester (3.49) 112

#### 3.4.3.2 Attempted synthesis of 4-substituted Aze 3.53 from allylic alcohol 3.51 by $S_N2'$ reaction

(2*S*,7*R*)-7-*tert*-Butoxycarbonylamino-8-(*tert*-butyl-diphenyl-silanyloxy)-6-oxo--2-(9-phenyl-9H-fluoren-9-ylamino)-Oct-4-enoic acid *tert*

-butyl ester (3.50)	113
(2 <i>S</i> ,7 <i>R</i> )-7- <i>tert</i> -Butoxycarbonylamino-8-( <i>tert</i> -butyl-diphenyl-silanyloxy)-6-hydroxy-2-(9-phenyl-9 <i>H</i> -fluoren-9-ylamino)-Oct-4-enoic Acid <i>tert</i> -Butyl Ester (3.51)	114
<b>3.4.3.3 Attempted synthesis of 4-vinyl Aze 3.59 from allylic alcohol 3.55</b>	
(2 <i>S</i> )-6-Hydroxy-[ <i>N</i> -(PhF)amino]-hex-4-enoic Acid <i>tert</i> -Butyl Ester (3.55)	115
6-Methansulfonyloxy- <i>N</i> -(PhF)-hex-4-enoic Acid <i>tert</i> -Butyl Ester (3.57) and <i>N</i> -(PhF)-1,2,3,4-tetrahydro-Pyridine-2-Carboxylic Acid <i>tert</i> -Butyl Ester (3.58)	116
<b>3.4.3.4 Synthesis of 4-vinyl Aze 3.65 via S<sub>N</sub>2' reaction of allylic chloride 3.64</b>	
(2 <i>S</i> )-2- <i>tert</i> -Butoxycarbonylamino-pent-4-enoic Acid Methyl Ester (3.63)	117
(2 <i>S</i> )-2- <i>tert</i> -Butoxycarbonylamino-6-chloro-hex-4-enoic Methyl Ester (3.64)	117
<i>N</i> -(Boc)-4-Vinyl Azetidine 2-Methyl Ester (3.65)	118
<b>3.4.4 Attempts to synthesis of 4-substituted Aze via intramolecular nucleophilic ring opening of an epoxide</b>	
(2 <i>S</i> )-2- <i>tert</i> -Butoxycarbonylamino-3-oxiranyl-Propionic Acid Methyl Ester (3.70)	120
(2 <i>S</i> )-2-(Toluene-4-sulfonylamino)-pent-4-enoic Acid Methyl Ester (3.73)	121

(2*S*)-3-Oxiranyl-2-(toluene-4-sulfonylamino)-Propionic Acid Methyl

Ester (3.74)

121

### 3.5 References

123

## Chapter 4: Conclusion and Perspectives

### 4.1 Conclusion, future work and perspectives

126

### 4.2 References

129

## Appendix 1

xxiii

<sup>1</sup>H NMR and <sup>13</sup>C NMR of compounds related to chapter 2

## Appendix 2

lxiii

<sup>1</sup>H NMR, <sup>13</sup>C NMR and HRMS of compounds related to chapter 3

## List of Figures

<b>Figure 1.1</b>	Schematic illustration of the various structural forms characteristic of proteins.	4
<b>Figure 1.2</b>	a: Conformations of peptides: definition of the $\phi$ , $\psi$ and $\omega$ torsional angles b: Torsional angles of an $\alpha$ -helix, $\beta$ -sheet (antiparallel) and type I and I' $\beta$ -turn conformations.	7
<b>Figure 1.3</b>	$\alpha$ -Aminocycloalkane carboxylic acid ( $\text{Ac}_{n+3c}$ )	8
<b>Figure 1.4</b>	Common amide bond isosteres	9
<b>Figure 1.5</b>	The backbone amide-to- <i>E</i> -olefin mutation eliminates both a H-bond acceptor (C=O) and a donor (N-H)	9
<b>Figure 1.6</b>	Phe-Phe <i>E</i> -olefin dipeptide isostere	10
<b>Figure 1.7</b>	Dehydroamino acid	11
<b>Figure 1.8</b>	a: <i>Erythro</i> (2 <i>S</i> ,3 <i>S</i> ) $\beta$ -methyltryptophan; b: (2 <i>S</i> ,3 <i>S</i> )-2',6'-dimethyl $\beta$ -methyltyrosine	12
<b>Figure 1.9</b>	Structures of representative proline and pipercolate analogues	14
<b>Figure 1.10</b>	L-Aze and examples of naturally and pharmaceutically important L-azetidine-2-carboxylic acid derivatives	15
<b>Figure 1.11</b>	Structures of cis-2,4-azetidine dicarboxylic acid from extracts of red-mold rice	28
<b>Figure 2.1</b>	Representative Aze-Xaa amino acid chimeras	46
<b>Figure 2.2</b>	Synthesis of $\beta,\beta$ -dimethyl-Aze by Goodman	47
<b>Figure 2.3</b>	Synthesis of Fmoc-Aze- <i>O</i> <i>t</i> Bu <b>2.18</b> from aspartate <b>2.13</b>	49
<b>Figure 2.4</b>	Synthesis of 3-Allyl 1-PhF-Aze (2 <i>S</i> ,3 <i>S</i> )- and (2 <i>S</i> ,3 <i>R</i> )- <b>2.1</b>	50

<b>Figure 2.5</b>	Long distance NOE correlations for the stereochemical assignments of (2 <i>S</i> ,3 <i>R</i> )- and (2 <i>S</i> ,3 <i>S</i> )-3-allyl-1-PhF-azetidine-2-carboxylates <b>2.1</b>	51
<b>Figure 2.6</b>	Reduction and hydroboration of olefin <b>2.1</b> ; synthesis of Nle-Aze chimera <b>2.2</b>	52
<b>Figure 2.7</b>	Synthesis of Lys-Aze and $\alpha$ -Aminoadipate-Aze chimeras <b>2.3</b> and <b>2.4</b>	54
<b>Figure 3.1</b>	Dihedral angles constrained by an azabicyclo[X.Y.0]alkane amino acid in a peptide	76
<b>Figure 3.2</b>	<i>N</i> -Boc-5-vinyl pyrrolidine-2-methyl ester made by intramolecular S <sub>N</sub> 2' cyclizations	78
<b>Figure 3.3</b>	Fused azetidone targets	79
<b>Figure 3.4</b>	Suggested diastereomers and the carbamate <i>cis</i> and <i>trans</i> -isomers of <i>N</i> -Boc 4-vinyl azetidone 2-methyl ester <b>3.65</b>	94

## List of Tables

<b>Table 1</b>	Examples of biologically active peptides	2
----------------	--	---

## List of Schemes

<b>Scheme 1.1</b>	Synthesis of ( $\pm$ ) and (+)-Aze	16
<b>Scheme 1.2</b>	Synthesis of ( $\pm$ ) Aze from 2-pyrrolidinone <b>1.7</b>	17
<b>Scheme 1.3</b>	Synthesis of ( $\pm$ )-Aze	17

<b>Scheme 1.4</b>	Resolution of DL-Aze	18
<b>Scheme 1.5</b>	Enzymatic resolution of <i>N</i> -substituted Aze	18
<b>Scheme 1.6</b>	Synthesis of L-Aze from homoserine lactone <b>1.19</b>	19
<b>Scheme 1.7</b>	Synthesis of (+)-Aze and (-)-Aze by intramolecular alkylation	20
<b>Scheme 1.8</b>	Synthesis of Phe-Aze, Nal-Aze, and Leu-Aze chimeras	22
<b>Scheme 1.9</b>	Synthesis of (-)- <i>trans</i> -2-carboxyazetidide-3-acetic acid	23
<b>Scheme 1.10</b>	Synthesis of 3-substituted (2 <i>R</i> ,3 <i>S</i> )- and (2 <i>S</i> ,3 <i>R</i> )-Aze <b>1.41</b>	24
<b>Scheme 1.11</b>	Synthesis of $\beta,\beta$ -dimethyl-Aze	25
<b>Scheme 1.12</b>	Synthesis of enantiopure 3-phenyl Aze <b>1.53</b> as a phenylalanine Chimera	26
<b>Scheme 1.13</b>	Synthesis of 3-substituted Aze by employing SAMP/RAMP- Hydrazone methodology	27
<b>Scheme 1.14</b>	Synthesis of <i>N</i> -Boc-4-trifluoromethyl Aze	29
<b>Scheme 1.15</b>	Azetidine formation via Pd-catalyzed cyclization	31
<b>Scheme 1.16</b>	Synthesis of azetidine-2,4-dicarboxylates	32
<b>Scheme 1.17</b>	Synthesis of 4-olefin Aze via Wittig reaction of mono cyclic lactams	32
<b>Scheme 3.1</b>	Reported synthesis of azetidine-3-ones	77
<b>Scheme 3.2</b>	Synthesis of 2-carboxy-3-oxoazetidide <b>3.2</b> from $\alpha$ -diazo $\beta$ -ketoester	80
<b>Scheme 3.3</b>	Synthesis of racemic polyoximic acid using 2-substituted azetidinone <b>3.17</b>	80
<b>Scheme 3.4</b>	Synthesis of enantiopure azetidine-3-one <b>3.20</b> from <i>N</i> -protected	

D-serine <b>3.18</b>	81
<b>Scheme 3.5</b> Synthesis of 2,4-dialkyl azetidone-3-one <b>3.23</b>	81
<b>Scheme 3.6</b> Attempted synthesis of 4-substituted 3-azetidinone <b>3.30</b>	83
<b>Scheme 3.7</b> Attempted synthesis of <i>N</i> -Boc 2,4-disubstituted azetidinone <b>3.34</b>	84
<b>Scheme 3.8</b> Synthesis of 3-oxo pyrrolidine phosphonate <b>3.37</b> from $\delta$ -amino $\alpha$ -diazo $\beta$ -ketophosphonate <b>3.36</b>	85
<b>Scheme 3.9</b> Synthesis of 2,4-substituted azetidinone <b>3.43</b> via $\beta$ -ketophosphonate <b>3.39</b>	86
<b>Scheme 3.10</b> Synthesis of 4-propenyl Aze <b>3.48</b> from allylic alcohol <b>3.46</b>	88
<b>Scheme 3.11</b> Attempted synthesis of 4-substituted Aze <b>3.53</b> starting from serine phosphonate <b>3.39</b>	90
<b>Scheme 3.12</b> Attempt for synthesis tosylate derivative of alcohol <b>3.55</b>	90
<b>Scheme 3.13</b> Synthesis of pipercolate <b>3.58</b> allyl alcohol <b>3.55</b> on route to mesylate <b>3.57</b>	91
<b>Scheme 3.14</b> Possible mechanism for the intramolecular <i>N</i> -alkylation leading to pipercolate <b>3.58</b>	92
<b>Scheme 3.15</b> Synthesis of 2-carboxy-5-vinylpyrrolidine <b>3.11</b> using AgOTf in S <sub>N</sub> 2' alkylation	92
<b>Scheme 3.16</b> Synthesis of vinyl azetidine <b>3.65</b>	93
<b>Scheme 3.17</b> Synthesis of azetidine ring from epoxide	95
<b>Scheme 3.18</b> Attempts to synthesize 4-substituted Aze <b>3.71</b> from epoxide <b>3.70</b>	96
<b>Scheme 3.19</b> Synthesis of epoxide <b>3.74</b> from olefin <b>3.63</b>	97

- Scheme 4.1** Retro synthesis of target azabicyclo[4.2.0]alkane amino acid **3.12**  
from azetidine phosphonate **3.41** 127
- Scheme 4.2** Retro synthesis of target azabicyclo[5,2,0]alkane **3.13** from vinyl  
azetidine **3.65** 127



## Abbreviations

$[\alpha]_D$	optical rotation
aq	aqueous
Aze	Azetidine-2-carboxylic acid
Bn	Benzyl
bs	broad single
Boc	<i>tert</i> -butoxycarbonyl
DCM	dichloromethane
DMF	<i>N,N</i> -dimethylformamide
d	doublet
dd	doublet of doublet
DIBAL-H	Diisobutylaluminum hydride
ee	enantiomeric excess
Fmoc	9-flourenylmethyloxycarbonyl
g	gram
Glu	Glumatic acid
h	hour
HRMS	High Resolution Mass Spectrometry
IR	Infrared spectroscopy
<i>J</i>	coupling constant
LiHMDS	lithium hexamethyldisilazane
KHMDS	potassium hexamethyldisilazane
lit.	literature

m	multiplet
Me	methyl
mg	milligram
$\mu\text{M}$	micromolar
min	minutes
MHz	megahertz
mL	milliliter
mmol	millimole
mp	melting point
Ms	methanesulfonyl
MS	Mass spectrum
NMR	Nuclear Magnetic Resonance
Ph	phenyl
PhF	9-(9-phenylflourenyl)
ppm	parts per million
rt	room temperature
s	singlet
t	triplet
t-Bu	<i>tert</i> -butyl
TBDMS	<i>tert</i> -butyl dimethylsilyl
TBDPS	<i>tert</i> -butyl diphenylsilyl
TFA	trifluoroacetic acid
THF	tetrahydrofuran

TLC

thin layer chromatography

TMS

trimethylsilyl

**CHAPTER 1**

**Introduction**

## 1. Peptide and peptide mimicry

### 1.1.1 Peptides and proteins:

A peptide is a chain of amino acids covalently linked together by amide bonds. Longer peptides (usually more than 50 residues) are called proteins. Interest in peptide science has been great due to their remarkable biological and structural properties. Table 1 lists some representative short natural peptides and their biological properties.<sup>1,2</sup>

**Table 1** Examples of biologically active peptides.

Name	No. of residues	Biological property
Thyrotropin-releasing hormone (TRH)	3	A hormone that controls the release of another hormone (thyrotrophin) in the body, and also affects the central nervous system
Enkephalins	5	Found in the brain, these peptides are involved in the control of pain sensations.
Phalloin	7	A poisonous bicyclic peptide, found in the Deathcap toadstool
Angiotensin II	8	This peptide is a hypertensive agent used by the human body to increase blood pressure.
Oxytocin	9	A hormonal cyclic nonapeptide which, among other things, induces labour in pregnancy
Vasopressin	9	A cyclic peptide antidiuretic hormone that induces contraction of smooth muscles.
Gramicidin S	10	A cyclic decapeptide antibiotic
Somatostatin	14	A cyclic peptide hormone that inhibits the secretion of growth hormone, insulin and glucagon.

Peptides exhibit numerous activities in human physiology as neurotransmitters, neuromodulators, hormones, antibiotics, growth factors, cytokines, and antigens. They influence essentially all vital physiological processes via inter- and intracellular communication, and signal transduction mediated through various classes of receptors.<sup>3,4</sup>

An important goal of peptide research has been to elucidate the relationship between the

three-dimensional (3D) structure and biological activity of a peptide. Such information is useful for developing therapeutic agents to control or intervene in disease states involving peptide receptors.

### 1.1.2 Structure of peptides:

Peptides share a common structure featuring a polyamide backbone and side chains linked to the  $\alpha$ -carbons of the amino acid residues. The primary structure of a peptide consists of the linear amino acid sequence (Figure 1.1).<sup>5</sup>

The secondary structure of a peptide describes local conformations such as  $\alpha$  helices and  $\beta$  strands. The formation of secondary structure in a polypeptide chain is usually contingent upon the primary structure and can be affected significantly by its environment. Secondary structure elements typically arrange themselves in motifs that give rise to higher ordered structures by the close packing of side chains from adjacent  $\alpha$  helices or  $\beta$  strands or inter-residue H-bonds (Figure 1.1).<sup>5</sup>

Tertiary structure refers to the complete three-dimensional structure of a given protein; the spatial relationship of different secondary structures to one another within a polypeptide chain and the fold of these secondary structures into a three-dimensional form. The interactions of different domains are governed by several forces such as hydrogen bonding, hydrophobic interactions, electrostatic interactions and van der Waals forces.

Many proteins contain two or more different polypeptide chains that are held in association by the same non-covalent interactions that stabilize the tertiary structures of proteins. Proteins with multiple polypeptide chains are termed oligomeric proteins. The

structure formed by monomer-monomer interaction in an oligomeric protein is known as quaternary structure.

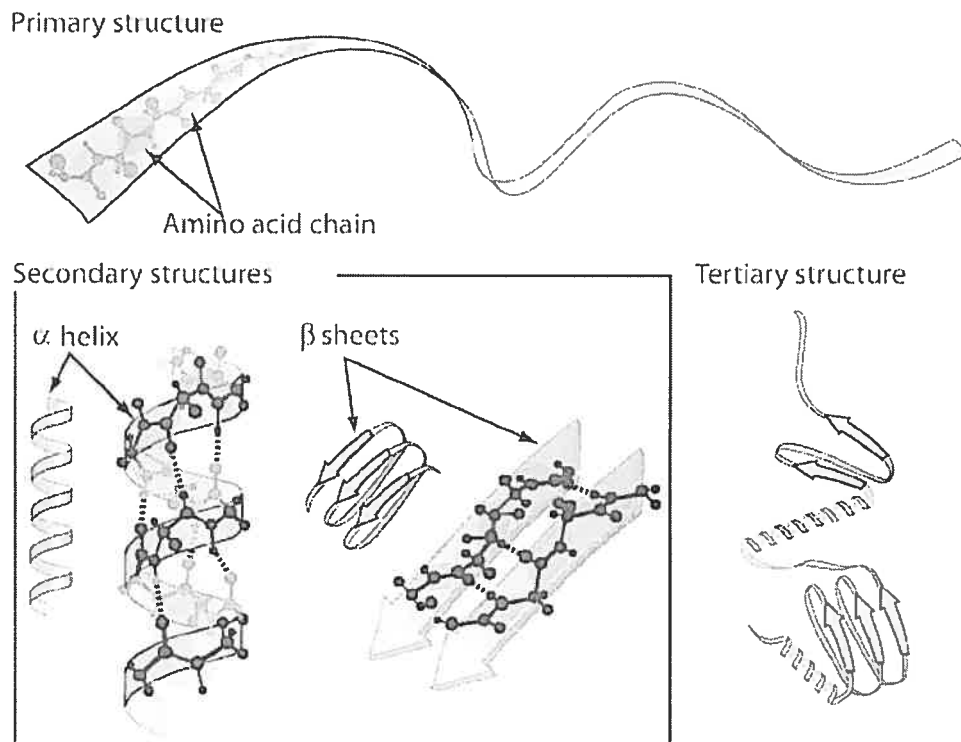

Figure 1.1: Schematic illustration of the various structural forms characteristic of proteins. The primary structure is determined by the linear sequence of amino acids. The secondary structure consists in chain segments that may have  $\alpha$ -helical or  $\beta$ -sheet structure. The entire amino acid chain that forms the protein consists of connected segments of secondary structure. These come together to form the tertiary structure of the protein.<sup>5</sup>

### **1.1.3 The drawbacks of the use of peptides:**

For peptide-based drug design, there are several major considerations that can limit the clinical application of peptides such as: (i) rapid degradation by many specific or nonspecific peptidases under physiological conditions; (ii) conformational flexibility which allows a peptide to bind to more than one receptor or receptor subtype leading to undesirable side effects; (iii) poor absorption and transportation because of their high molecular mass and the lack of specific delivery systems, especially for peptides which require passage across the blood-brain-barrier (BBB) to act in the central nervous system (CNS).<sup>6-10</sup>

### **1.1.4 Peptide mimicry and its importance:**

A peptide mimic refers to a molecule resembling a peptide, which can act like the peptide as a ligand of a biological receptor or inhibit the effect of the natural peptide at its receptor. Peptide-based enzyme inhibitors may also be considered peptide mimics. From a medicinal chemistry point of view, peptide mimics replicate the topology of the peptide; however, they lack aspects of the peptide structure that may be drawbacks to the use of the peptide as a drug. In peptide mimics, the peptide backbone and side chain conformations may be constrained to allow a better interaction with the enzyme or receptor protein to which the peptide binds.<sup>6, 7, 10</sup>

### **1.1.5 The importance of peptidomimetics in drugs:**

The use of peptidomimetics to overcome the limitations inherent in the physical characteristics of peptides has become an important strategy for improving the



therapeutic potential of peptides. As one of the major efforts in organic chemistry, a variety of molecules have been designed to mimic the secondary structures of peptides, such as  $\alpha$ -helices,  $\beta$ -turns, and  $\beta$ -strands. To explore structure-activity relationships (SAR) of bioactive peptides, a number of strategies have been developed that feature incorporation of conformationally constrained amino acids, modification of the peptide backbone by amide bond isosteres, cyclizations, attachment of pharmacophores to a template or scaffold, and the syntheses of non-peptide analogues.<sup>7,10</sup> Peptidomimetics are desired which exhibit the same biological effects as natural peptides, and at the same time, are more metabolically stable. Peptidomimetics can possess favourable attributes for drug development including, a conformationally restrained structure that may minimize binding to non-target receptors and enhance activity at the desired receptor, and improved transport properties through cellular membranes. Certain peptide mimics, such as amide isosteres,<sup>8</sup> retro-inverso peptides,<sup>11</sup> cyclic peptides<sup>12</sup> and non-peptidomimetics<sup>13</sup>, have exhibited a reduced rate of degradation compared to native peptides. Peptidomimetics with improved pharmacokinetic profiles may also be designed with molecular frameworks that direct the position of the pharmacophores.<sup>6, 14, 15</sup>

### 1.1.6 Different approaches for peptide mimicry:

There are several different approaches for peptide mimicry:

1) Backbone *N*-alkylation facilitates *cis-trans* amide bond isomerization and changes the conformational space available to the  $\phi$ ,  $\psi$  and  $\chi$  dihedral angles (Figure 1.2). *N*-Alkylation eliminates the hydrogen bonding capability of the amide bond. *N*-Methylated amino acids have been incorporated into bioactive analogues of the opioid peptides,<sup>16</sup>

34) segment of parathyroid hormone (PTH), several analogues of hPTH(1-11) were synthesized (Figure 1.3). The substitution of the  $C_{\alpha,\alpha}$ -dialkylated amino acid residue  $Ac_{5c}$  in hPTH(1-11) at position 1 resulted in a potent analogue with biological activity 3500-fold higher than that of native PTH(1-11) and 15-fold weaker than that of the native sequence hPTH(1-34).<sup>26</sup>

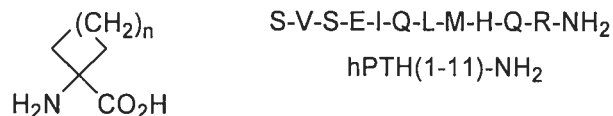

Figure 1.3:  $\alpha$ -Aminocycloalkane carboxylic acid ( $Ac_{n+3c}$ )

3) D-Amino acid substitutions can favour formation of  $\beta$ -turn structures. Replacement of some or even all L-amino acids with their corresponding D-amino acids in a peptide sequence confers resistance to proteolytic degradation. Another important advantage for peptide drug development is that D-amino acid analogues have been found to be significantly less immunogenic than their L-amino acid counterparts.<sup>27</sup> D-Amino acid residues may stabilize a reverse  $\beta$ -turn (hairpin) structure, as well as increase potency, affinity and activity due to the importance of  $\beta$ -turn conformations for biological activity.<sup>28</sup>

4) Peptide amide bond isosteres may restrain the  $\omega$ -dihedral angle to values  $0^\circ$  or  $180^\circ$ , or allow greater freedom for rotation about this bond (Figure 1.4).

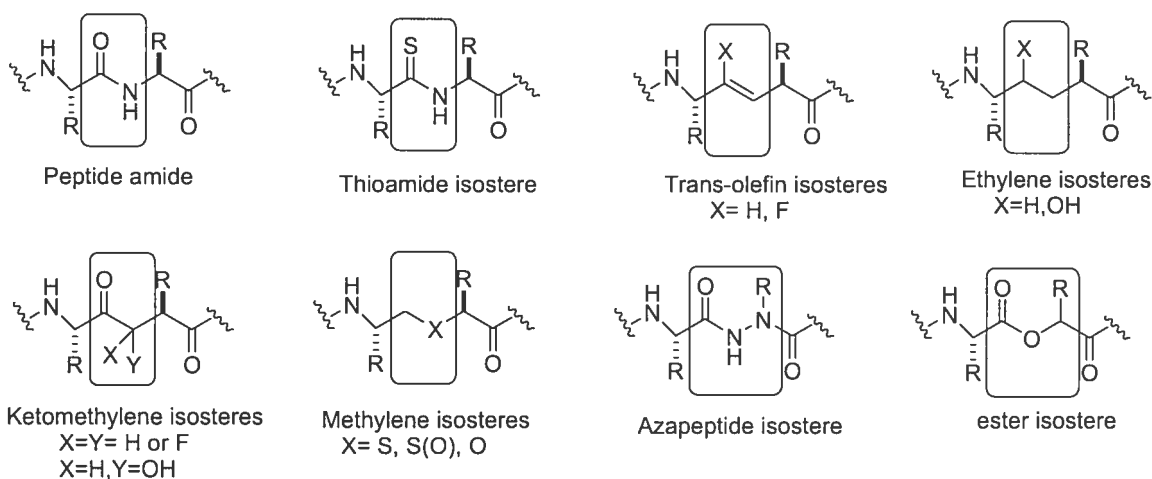

Figure 1.4: Common amide bond isosteres<sup>8</sup>

For example, it is possible to eliminate both a backbone H-bond acceptor (C=O) and a donor (N-H) by replacing the amide functionality with an *E*-alkene moiety (Figure 1.5).

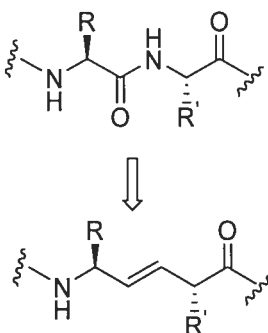

Figure 1.5: The backbone amide-to-*E*-olefin mutation eliminates both a H-bond acceptor (C=O) and a donor (N-H).

The Phe-Phe *E*-olefin dipeptide isostere (Fig. 1.6) was incorporated into the 40 residue Alzheimer's amyloid peptide, referred to as A $\beta$ (1-40), in place of phenylalanines 19 and 20 utilizing a Boc/benzyl solid phase strategy, to examine the role of intermolecular H-bonding in the process of amyloidogenesis, that may cause Alzheimer's disease. This amide-to-*E*-alkene backbone mutation precludes amyloid formation, but not spherical

aggregate formation, providing insight into the structural requirements of amyloidogenesis.<sup>29</sup>

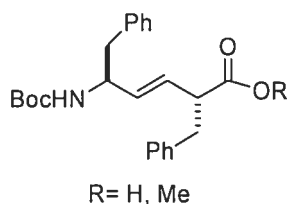

Figure 1.6: Phe-Phe *E*-olefin dipeptide isostere

5) Cyclic amino acids, such as proline,<sup>30,31</sup> can lower the energy differences between the *cis* and *trans*-amide isomers and bias global restrictions of the conformation of a peptide's  $\phi$  and  $\psi$  dihedral angles towards forming  $\beta$ - or  $\gamma$ -turns. Proline is often found at the end of an  $\alpha$  helix or in turns or loops. Unlike other amino acids which exist almost exclusively in the *trans*-amide form in polypeptides, proline can exist in the amide *cis*-conformation in peptides.<sup>32</sup> Introducing pipercolic acid, called homoproline, instead of proline into peptides is reported to introduce significant changes in biological activity and has led to interesting model compounds for studies on peptide conformation.<sup>33</sup> Derivatives of pipercolic acid have also found a role as  $\beta$ -turn mimics<sup>34</sup> as well as precursors for natural product synthesis<sup>35</sup> and rigid analogues of prolyl amide bonds in peptides.<sup>36</sup>

6) Dehydroamino acids (Figure 1.7) can restrict the  $\chi$  dihedral angle to value of  $0^\circ$  (*Z*) or  $180^\circ$  (*E*). For example,  $\alpha,\beta$ -dehydrophenylalanine ( $\Delta$ Phe) has been used as a conformationally restricted residue in the design of polypeptide helices. Dehydroamino acids generally favor the formation of  $\beta$  or  $\gamma$ -turns when placed in the (i+2) position of

the putative turn sequence. In addition, sequential placement of  $\Delta$ Phe in a peptide induces repeated  $\beta$ -turns, that form a  $3^{10}$  helix-like structure (Figure 1.7).<sup>37</sup>

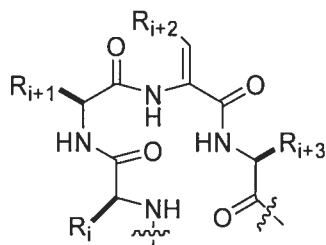

Figure 1.7: Dehydroamino acid

7)  $\beta$ -Alkylation has been used to constrain the  $\chi$  dihedral angle, and may also effect backbone conformation. Introduction of methyl groups at the  $\beta$ -position of Phe and related aryl alanines has been used to orient the aromatic ring. Additional alkyl groups usually enhance the lipophilicity of the peptide analogue, and can thus help in crossing the blood-brain barrier. Figure 1.8 represents structures of some novel amino acids that are constrained in  $\chi$  space.<sup>38</sup> For example, the constrained tyrosine derivative, (2*S*,3*S*)-2',6'-dimethyl  $\beta$ -methyltyrosine<sup>39</sup> [(2*S*,3*S*)-TMT] (Figure 1.8 b) was synthesized and incorporated into cyclic analogs of [D-Pen<sup>2</sup>,D-Pen<sup>5</sup>]enkephalin (DPDPE) ( $\delta_1$ ). Because of the methyl substitution in the tyrosine derivative (Figure 1.8 b), rotation about the  $\chi_1$  and  $\chi_2$  torsion angles was restricted about the C <sup>$\beta$</sup> -C <sup>$\gamma$</sup>  bond. This tyrosine analogue has been used in the study of the role of side chain dynamics in peptide-receptor interactions and protein functions.<sup>39</sup>

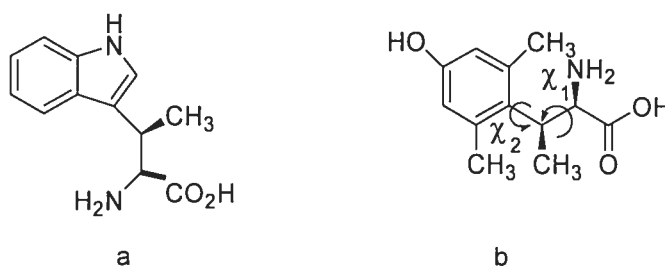

Figure 1.8: **a:** *Erythro* (2*S*,3*R*)  $\beta$ -methyltryptophan<sup>40</sup>; **b:** (2*R*,3*S*)-2',6'-dimethyl  $\beta$ -methyltyrosine<sup>39</sup>

In summary, incorporation of peptidomimetics into peptides can offer significant advantages for drug development. These benefits include increased bioavailability, better transport through cellular membranes, decreased rates of excretion, increased selectivity and decreased hydrolysis by peptidases. A tremendous variety of constrained amino acids have been developed to rigidify particular amino acids and peptide sequences. Control of backbone and side chain conformation by way of steric and electronic factors can be implemented through modifications of the peptide backbone. Mimetics are usually designed based on analogy to the native peptide structure, then optimized to give the best possible pharmacokinetic properties.

## 1.2 Cyclic amino acid chimeras

### 1.2.1 Proline and pipercolic acids as higher homologues of azetidine-2-carboxylic acid

As mentioned, cyclic amino acids, such as proline and its higher homologue pipercolic acid, are often used as conformationally constrained amino acids in peptide mimicry to study conformation activity relationships in peptides.<sup>41-44</sup> These amino acids increase conformational freedom and favour turn geometry.  $\beta$ -Substituted prolines and pipercolates have been also been designed to serve as amino acid chimeras on which the functional

groups of the amino acid side-chain are combined with the conformational rigidity of the cyclic amino acid residue. Several chimeras based on proline bodies have been used to study the relationship between the side-chain geometry and the bioactivity in different peptides.<sup>45,46,32</sup> For example, proline-amino acid chimeras have been used in place of natural amino acids in peptide-based enzyme inhibitors<sup>47</sup> and in peptide ligands of G-protein coupled receptors (GPCRs). In the latter case, tyrosine was replaced with either *trans*-3-(4'-hydroxyphenyl)proline (*t*-Hpp) or *cis*-3-(4'-hydroxyphenyl)proline (*c*-Hpp) in  $\delta$  opioid receptor selective tetrapeptide Tyr-c[D-Cys-Phe-D-Pen]OH and displayed  $\delta$  receptor binding affinity similar to the parent Tyr<sup>1</sup>-containing peptide (Figure 1.9).<sup>48</sup>

$\beta$ -Substituted pipercolic acids have similarly been synthesized to serve as amino acid chimeras. For example, 3-substituted Pipercolic acid **1.2** was introduced into the potent and sst5 subtype selective somatostatin mimetic **1.1** (IC<sub>50</sub> = 87 nM). The resulting analog **1.3** (IC<sub>50</sub> = 41 nM) exhibited 2-fold and 25-fold binding enhancement against the somatostatin receptor subtypes sst5 and sst4, relative to lead compound **1.1**, respectively (Figure 1.9).<sup>49</sup>

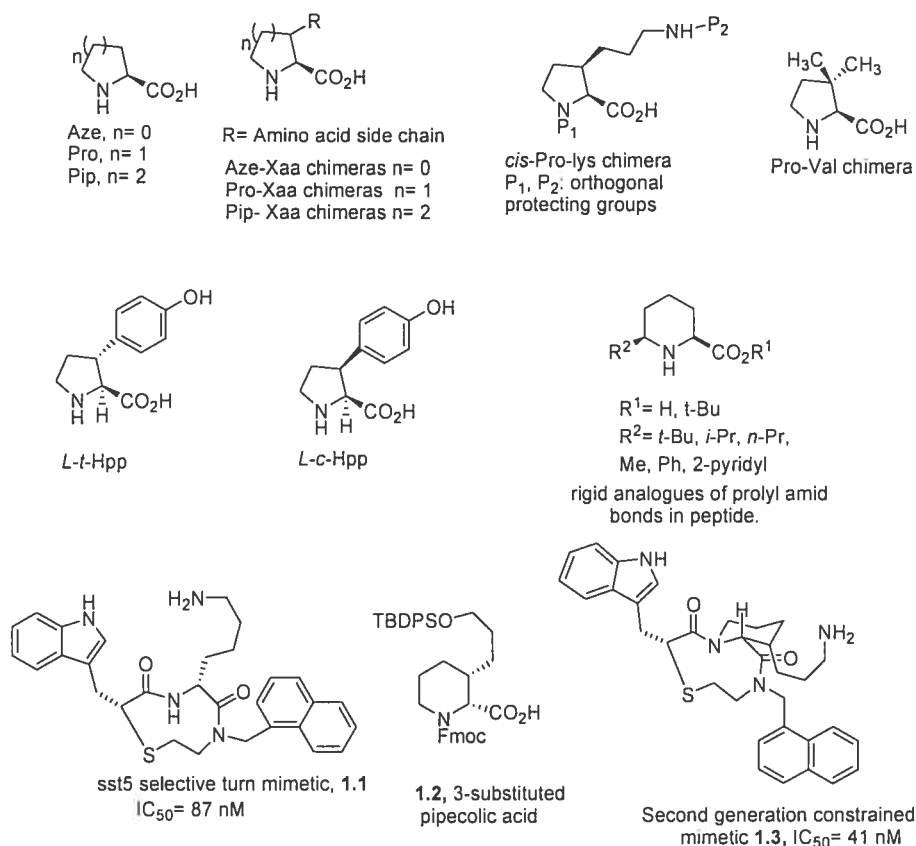

Figure 1.9: Structures of representative proline and pipercolate analogues.

### 1.3 Azetidine-2-carboxylic acids (Aze) and their applications

#### 1.3.1 Applications of azetidine 2-carboxylic acid:

L-Azetidine-2-carboxylic acid (Aze) is a four member cyclic amino acid discovered by Fowden<sup>50</sup> and Vitanen<sup>51</sup> in *Convallaria majalis* and *Polgonatum officinale*, two members of the *Liliaceae* family. Commercially available and isolated from hydrolysates of natural plants,<sup>52</sup> L-azetidine-2-carboxylic acid occurs in high concentrations in a variety of species.<sup>53</sup>

L-Aze exhibits growth inhibitory effects in many biological systems.<sup>54</sup> L-Aze, as a constrained amino acid, has also found applications for the modification of peptide conformation.<sup>55-60</sup> L-Aze has also been applied in synthesis as an additive for asymmetric



reduction of ketones,<sup>61</sup> Michael additions,<sup>62</sup> cyclopropanations,<sup>63</sup> and the Diels-Alder reaction.<sup>64</sup>

Some substituted Aze analogs are part of natural and pharmacologically interesting products such as medicanine,<sup>65</sup> nicotianamine,<sup>66</sup> mugineic acid,<sup>67</sup> and red-mold rice fermentation products, some of which seem to be involved in iron transport processes of certain plants.<sup>68</sup> L-Aze derivatives have served as active pharmaceutical ingredients, in for example, the non-opioid analgesic agent ABT-594(*R*)<sup>69</sup> and the thrombin inhibitor melagatran (Figure 1.10).<sup>70</sup>

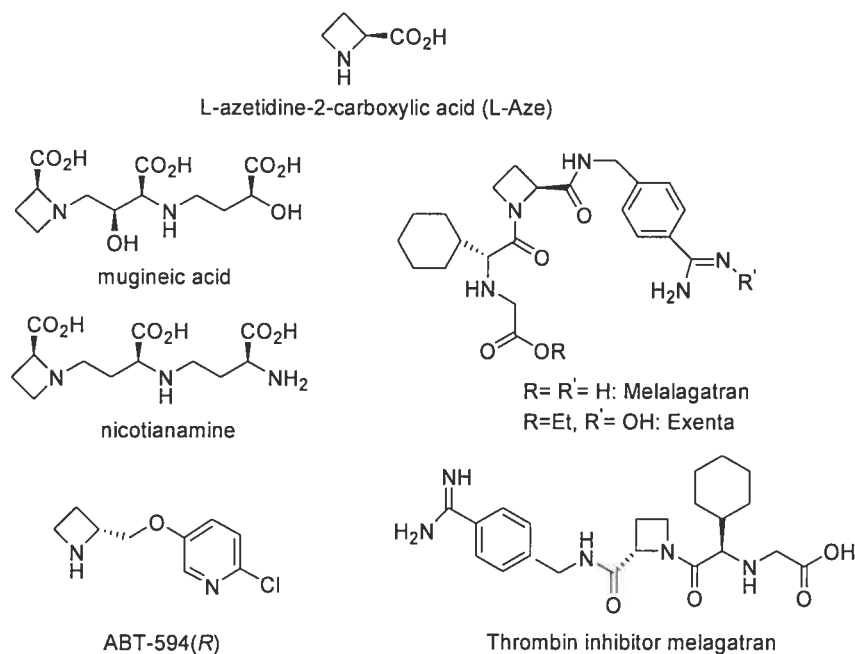

Figure 1.10: L-Aze and examples of naturally and pharmaceutically important L-azetidine-2-carboxylic acid derivatives.

### 1.3.2 Synthesis of azetidine 2-carboxylic acids:

Cyclic  $\alpha$ -amino acids have been the subject of considerable research in the last decade because of the physiological activities associated with these derivatives.<sup>41,71,72</sup> Although a number of syntheses of cyclic amino acids such as proline and pipercolic acid have been developed, fewer methods are available for making azetidine-2-carboxylic acid derivatives.

#### 1.3.2.1 Synthesis of DL- and D-Aze starting from 2-bromo or 2-chloro-4-aminobutanoic acid:

Racemic and enantiomerically enriched Aze have been synthesized respectively from  $\gamma$ -aminobutyric acid **1.4** and L- $\alpha,\gamma$ -diaminobutyric acid **1.6**. Bromination of amino acid **1.4** in the presence of red phosphorous gave  $\alpha$ -bromo derivative **1.5**. Ring annulations were effected using 0.5 N barium hydroxide in  $H_2O$  to yield ( $\pm$ )-Aze and optically active (+)-Aze (Scheme 1.1).<sup>73</sup>

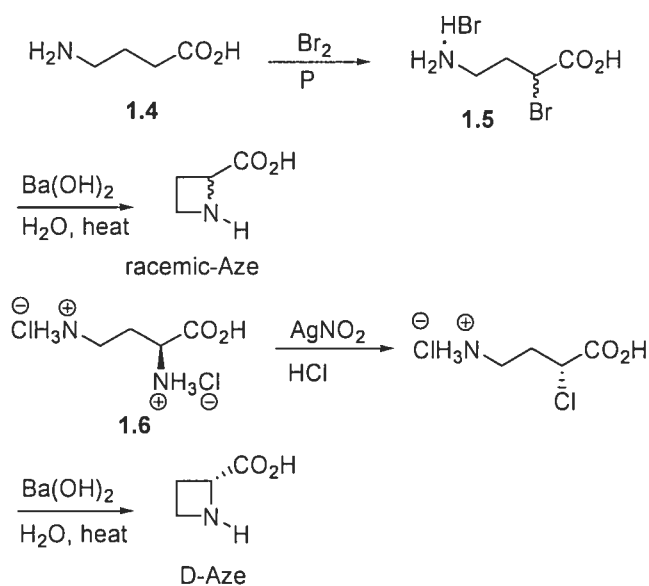

Scheme 1.1: Synthesis of ( $\pm$ ) and (+)-Aze

In addition, racemic Aze was also prepared from  $\alpha$ -bromo-  $\gamma$ -amino acid **1.10** using *Z*-pyrrolidinone **1.7** as a starting material.<sup>74</sup>

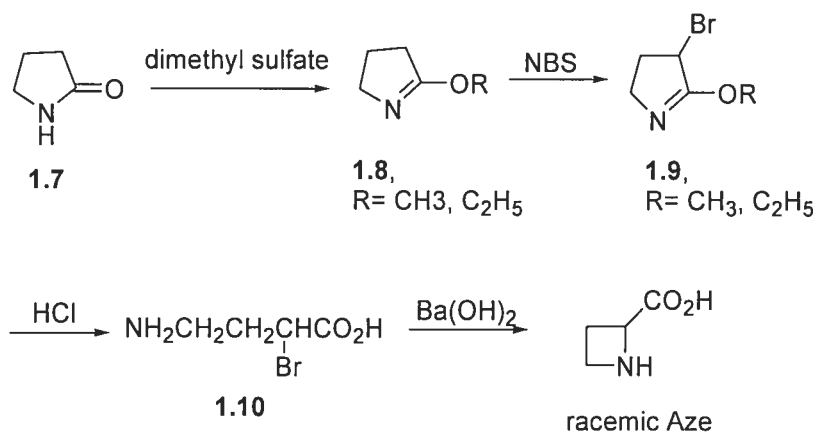

Scheme 1.2: Synthesis of ( $\pm$ ) Aze from 2-pyrrolidinone **1.7**.

### 1.3.2.2 Synthesis of Aze starting from $\gamma$ -butyrolactone:

The synthesis of the ( $\pm$ )-Aze was achieved from  $\gamma$ -butyrolactone by a route featuring bis-alkylation of a given amine (Scheme 1.3).<sup>75,76</sup>

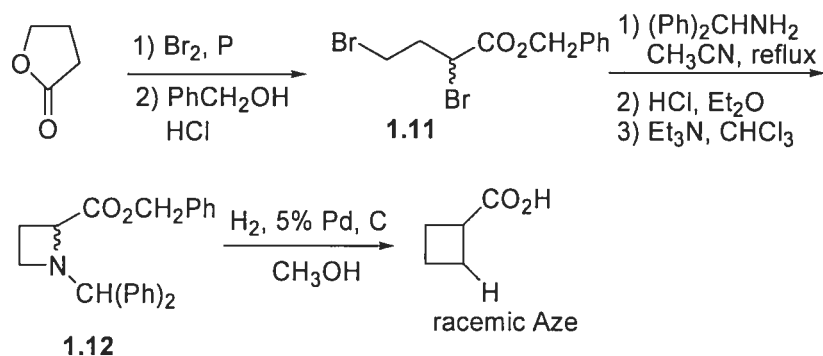

Scheme 1.3: Synthesis of ( $\pm$ )Aze.

Enantiomerically enriched D- and L-Aze has been obtained by resolution (Scheme 1.4).<sup>77</sup>

First, the DL-amino acid was converted to its *N*-carbobenzyloxy derivative **1.13**.

Treatment with L-tyrosine hydrazide in MeOH yielded diastereomeric salts, which exhibited different solubilities in methanol.<sup>77,78</sup>

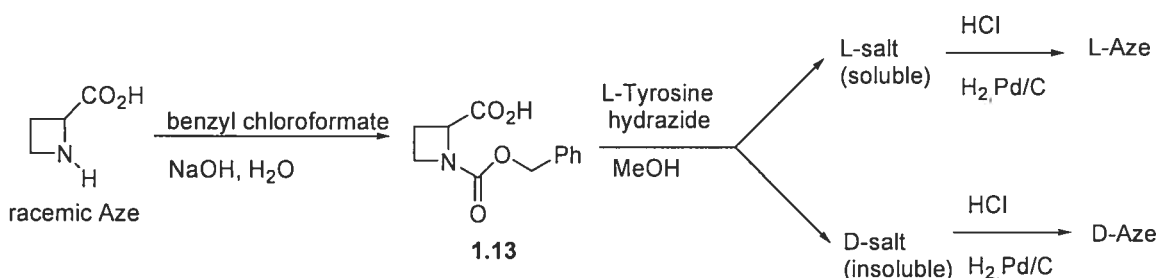

Scheme 1.4: Resolution of DL-Aze.

Enzymatic resolution of DL-*N*-substituted Aze has also been achieved using *Candida antarctica* (Scheme 1.5), which produced carboxamide **1.16** from *S*-ester **1.14** using ammonia as the nucleophile. *R*-Ester **1.15** did not react under these conditions.<sup>79</sup>

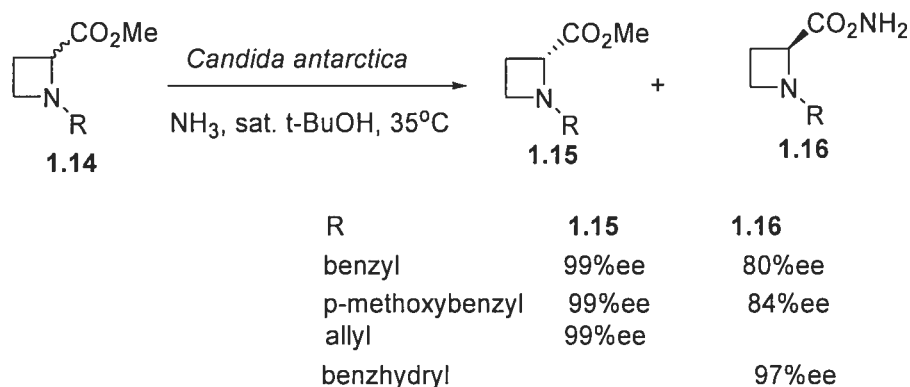

Scheme 1.5: Enzymatic resolution of *N*-substituted Aze.

### 1.3.2.3 Synthesis of L-Aze starting from (*S*)-*N*-toluenesulfonyl-homoserine lactone:

Enantiopure L-Aze was synthesized without resolution from *N*-toluenesulfonyl-L-methionine **1.17**, which was readily converted to *N*-toluenesulfonyl-lactone **1.19**. Treatment of L-homoserine lactone **1.19** with hydrogen bromide, followed by cyclization of **1.18** with sodium hydride provided *N*-toluenesulfonyl-L-Aze **1.18**. The

toluenesulfonamide was removed using sodium in liquid ammonia to give L-Aze in 62% overall yield (Scheme 1.6).<sup>80,81</sup>

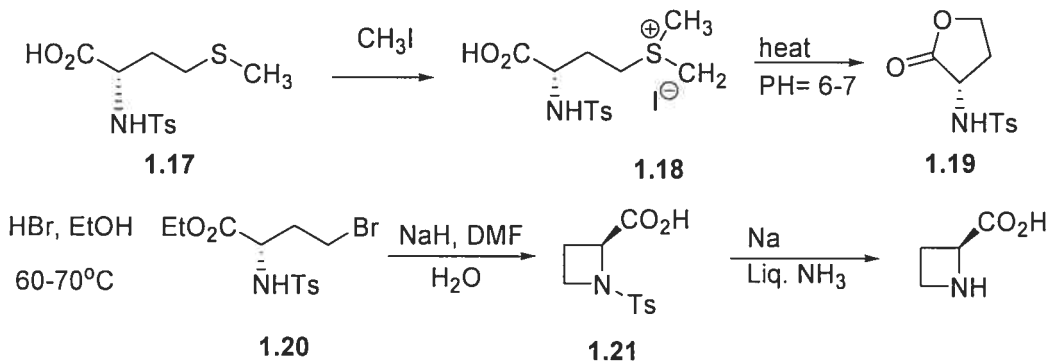

Scheme 1.6: Synthesis of L-Aze from homoserine lactone **1.19**.

#### 1.3.2.4 Asymmetric synthesis of (+)- and (-)-Aze from $\alpha$ -methylbenzyl amine as the source of chirality:

Construction of the azetidine ring has been achieved using an intramolecular alkylation of a linear substrate derived from  $\alpha$ -methyl benzyl amine as chiral aduct.<sup>82</sup>  $\alpha$ -Methylbenzyl amine **1.22** was subjected to two consecutive alkylations with bromoethanol and bromoacetonitrile to afford the tertiary amino alcohol **1.23**. Chloride **1.24** was prepared by reaction of alcohol **1.23** with thionyl chloride in dichloromethane. A 1:1 mixture of diastereoisomers (*S,S*)- and (*S,R*)-**1.25** were synthesized by intramolecular alkylation with potassium *tert*-butoxide in THF. The diastereoisomers were separated by column chromatography. Respective hydrolysis of nitriles **1.25** with concentrated hydrochloric acid, followed by hydrogenolysis of the HCl salt gave the desired (-)- and (+)-azetidine 2-carboxylic acids (Scheme 1.7).

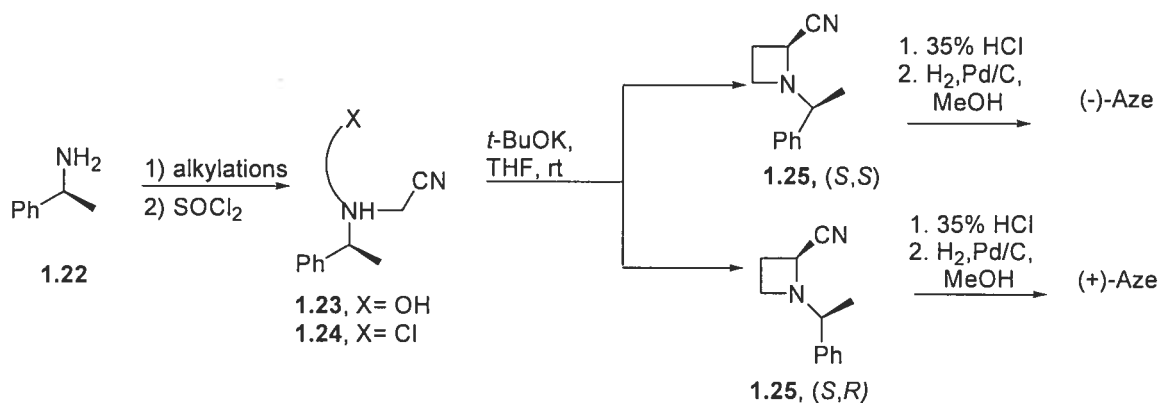

Scheme 1.7: Synthesis of (+)-Aze and (-)-Aze by intramolecular alkylation.

Employing benzyl  $\alpha$ -bromo acetate, instead of bromo acetonitrile in the alkylation step, gave a similarly unselective sequence, which provided Aze in similar overall yields.

In summary, prior syntheses of Aze have been reported; however, few provide a satisfactory route to either enantiomer in practical quantities. Asymmetric syntheses have required chemical and enzymatic resolution as well as the use of a chiral auxiliary. In light of the importance of Aze and substituted Aze as constituents of biologically active compounds, the development of new methodologies for synthesizing Aze analogues remains an important field of research.

## 1.4 Substituted azetidine-2-carboxylic acids

### Introduction:

During our research on the effect of azacycloalkane amino acids on peptide conformation, we became interested in employing  $\beta$  and  $\gamma$  substituted Aze analogues for studying secondary structure. A search of the literature revealed that there are few methods for selective and stereocontrolled introduction of alkyl substituents on the Aze

ring carbons. In spite of current interest in the synthesis and chemistry of azetidine 2-carboxylic acids, there are only a few reports on the synthesis of 3- and 4-substituted Aze analogues.

#### 1.4.1 3-Substituted azetidine 2-carboxylic acids:

As mentioned, there are few general methods for the synthesis of substituted Aze analogues. Several representative examples are presented below which deliver 3-substituted Aze analogs in enantiopure form.

##### 1.4.1.1 Synthesis of Phe-Aze, Nal-Aze, Leu-Aze chimeras:

Hanessian *et al.* used Oppolzer's sultam methodology for the preparation of enantiopure 3-substituted L-Aze analogs.<sup>83</sup> The camphor sultam derivative of glyoxalic acid O-benzyl oxime **1.26** on treatment with allylic halides and zinc dust was converted to allyl glycine **1.27**. Hydrolysis of the chiral auxiliary, esterification and *N*-protection produced *N*-benzyloxy tert-butyl amino esters **1.28**. Oxidation of the olefin followed by reduction of resulting aldehyde and mesylation provided the corresponding mesylate **1.29**. Hydrogenolysis followed by cyclization in the presence of NaHCO<sub>3</sub> gave L-Aze methyl esters **1.30 b-d** as mesylate salts. Hydrolysis of the ester with 3N HCl and purification on Dowex-50H<sup>+</sup> provided 3-aryl and 3-alkyl Aze derivatives **1.31 b-d** (Scheme 1.8). Unsubstituted Aze **1.31 a** was also prepared in a similar manner using allyl bromide.

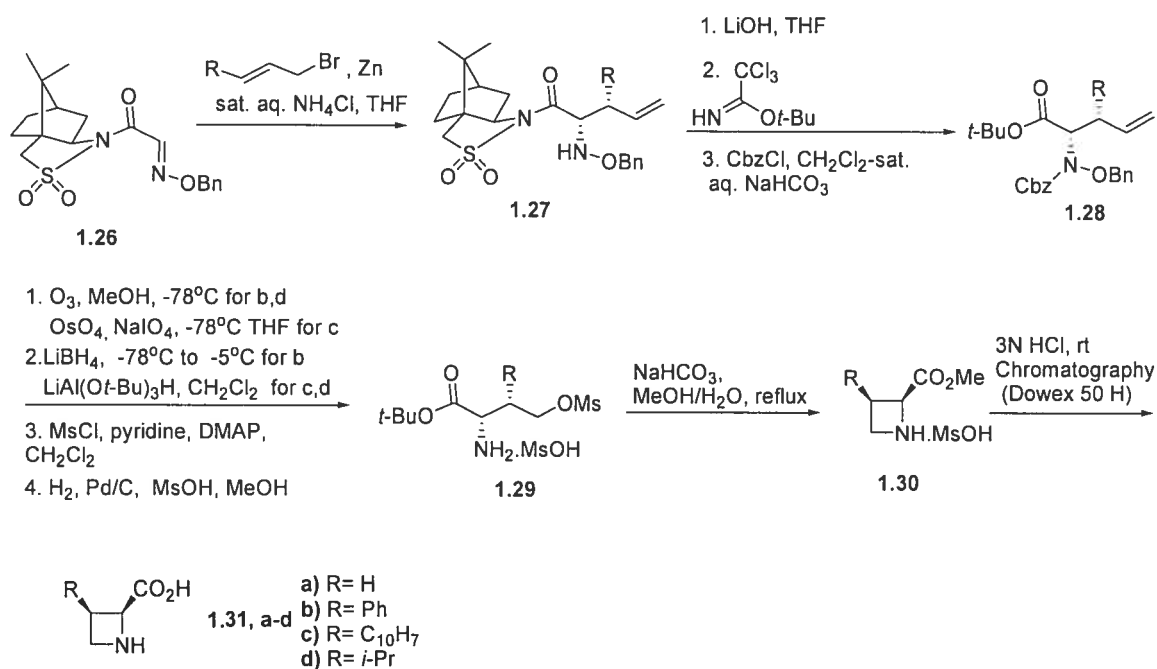

Scheme 1.8: Synthesis of Phe-Aze, Nal-Aze, and Leu-Aze chimeras

#### 1.4.1.2 Synthesis of the Glu-Aze chimera, (-)-*trans*-2-carboxyazetidide-3-acetic acid (*t*-CAA):

3-Carboxymethyl Aze, a Glu-Aze chimera was synthesized by allylation of a  $\beta$ -lactam enolate derived from D-aspartic acid, subsequent olefin oxidation and lactam reduction. D-Asp was transformed via its dibenzyl ester into  $\beta$ -lactam **1.32**. Lactam **1.32** was converted to its *N*-silyl lactam and hydrogenated to give *N*-silyl  $\beta$ -lactam 4-carboxylic acid **1.33**, which was treated with two equivalents of LDA to form the corresponding dianion, which was alkylated with allyl bromide. Esterification using diazomethane and silyl group cleavage provided allyl  $\beta$ -lactam methyl ester **1.34**. The lactam and ester moieties were reduced simultaneously with DIBAL-H. The azetidine nitrogen was protected by carbobenzyloxylation, and the alcohol was oxidized to the corresponding acid. The double bond of acid **1.35** was subjected to ozonolysis, and the resulting



aldehyde was oxidized with  $O_2/PtO_2$  to afford the *N*-protected azetidine diacid. Removal of the Cbz group by hydrogenolytic cleavage gave the desired azetidine diacid **1.36** (Scheme 1.9). The (+)-isomer of **1.36** was prepared in an identical fashion starting from L-aspartic acid. *t*-CAA was found to be an inhibitor of  $Na^+$ -dependent Glu uptake ( $5 \mu M$ ) and to act as a kainic acid receptor agonist ( $0.7 \mu M$ ).<sup>84</sup>

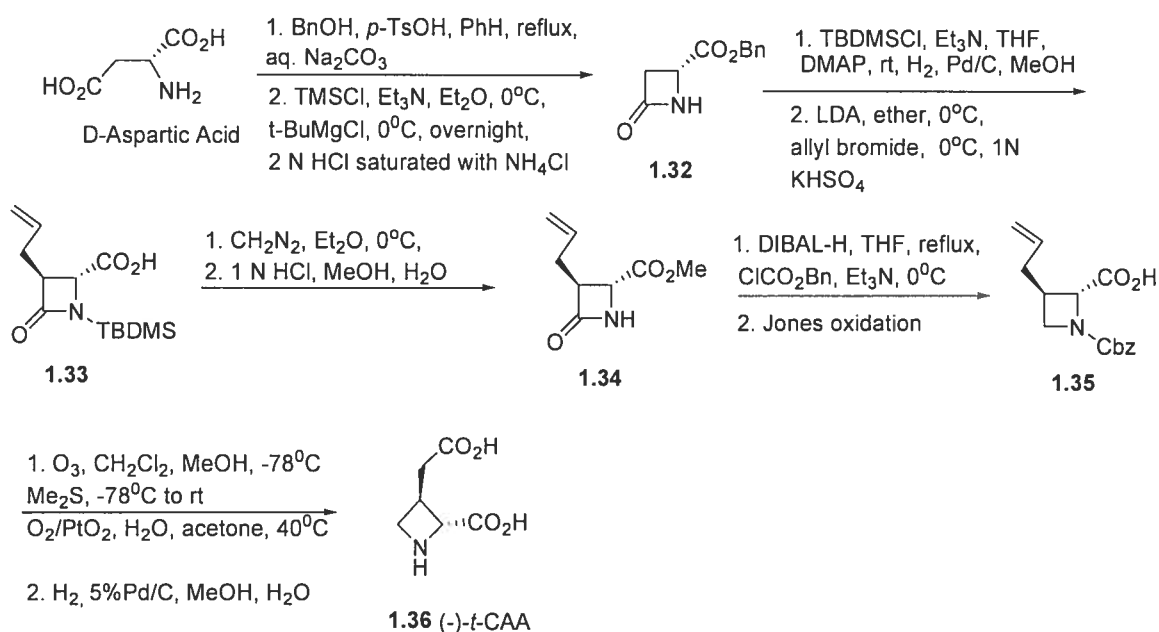

Scheme 1.9: Synthesis of (-)-*trans*-2-carboxyazetidine-3-acetic acid.

#### 1.4.1.3 Synthesis of (2*R*,3*S*)- and (2*S*,3*R*)-azetidine-2-carboxylic acids **1.41**:

(2*R*,3*S*)- and (2*S*,3*R*)-Methoxy-3-phenylazetidine-2-carboxylic acid **1.41** were synthesized from the commercially available enantiomerically pure amino diol **1.37** and D-serine **1.38**, respectively (Scheme 1.10).<sup>85</sup> Using a stereoselective photochemical ring closure of the amino ketone **1.39** and amino alcohol **1.40**, enantiopure (2*R*,3*S*)- and (2*S*,3*R*)- azetidines **1.41** were obtained in 71% yield.

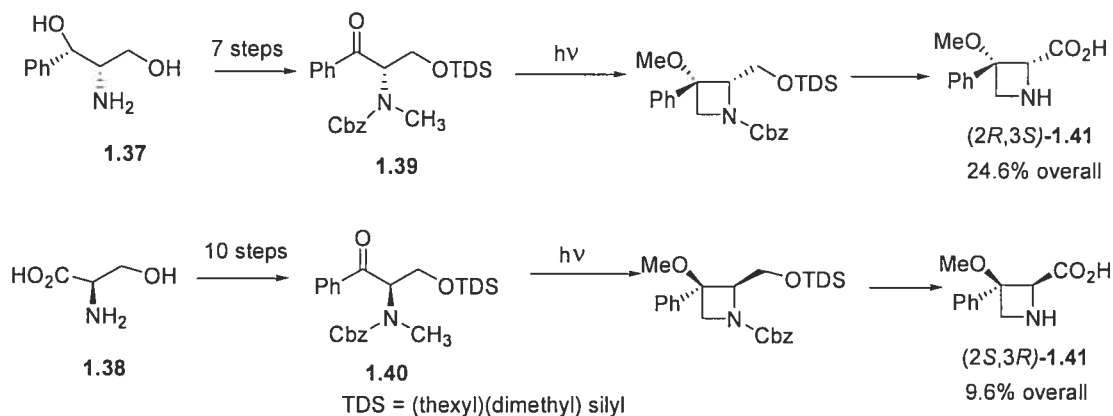

Scheme 1.10: Synthesis of 3-substituted (2*R*,3*S*)- and (2*S*,3*R*)-Aze **1.41**.

#### 1.4.1.4 Synthesis of the Val-Aze chimera, 3,3-dimethyl-azetidine 2-carboxylic acid :

In the course of syntheses of  $\beta,\beta$ -dimethylated amino acid building blocks,  $\beta,\beta$ -dimethyl-Aze **1.45** was synthesized from *N*-(PhF) aspartate dimethyl ester **1.42**. *N*-PhF-  $\beta,\beta$ -dimethyl D-Asp dimethyl ester **1.43** was obtained by dialkylation of dimethyl aspartate **1.42** using methyl iodide and KHMDS in THF in 91% yield. Regioselective reduction of the  $\beta$ -methyl carboxylate of *N*-PhF- $\beta,\beta$ -dimethyl-D-aspartate **1.43** to  $\beta,\beta$ -dimethyl-D-homoserine **1.44** was achieved using DIBAL-H in DCM. Activation of the resulting alcohol to the corresponding mesylate, followed by intramolecular nucleophilic displacement gave  $\beta,\beta$ -dimethyl-Aze **1.45** (Scheme 1.11).<sup>86</sup>

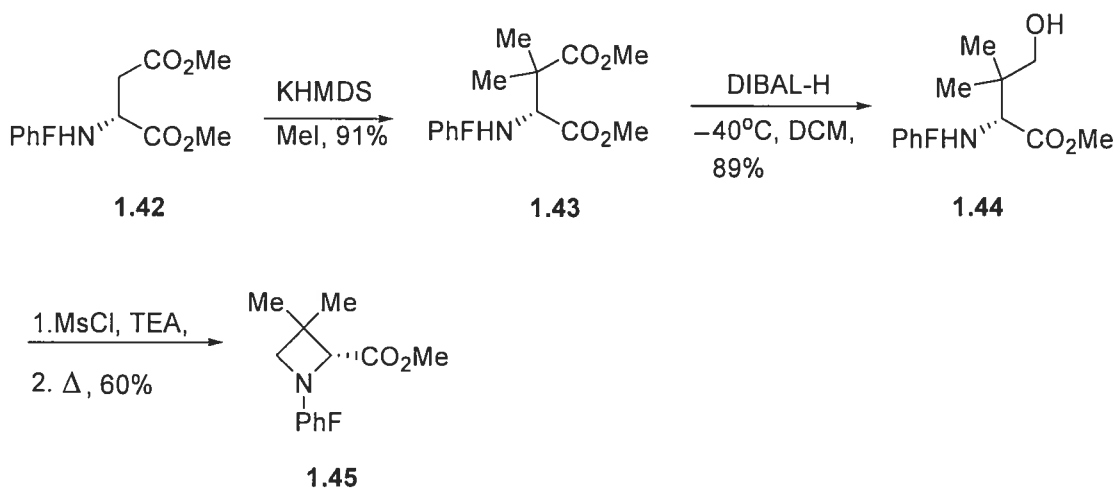
Scheme 1.11: Synthesis of  $\beta,\beta$ -dimethyl-Aze

#### 1.4.1.5 3-Phenyl Aze from $\beta$ -amino alcohol 1.46:

Enantiopure 3-phenyl Aze was synthesized from 2-cyano azetidines starting from phenylglycinol.<sup>87</sup> (R)-*N*-Benzyl phenylglycinol **1.49** was prepared through reductive alkylation, and then cyanomethylated in a two-step procedure involving ring opening of intermediate oxazolidines **1.48** with citric acid and KCN/EtOH. Chlorination of the cyanomethylated amino alcohol **1.49** with two equivalents of thionyl chloride in DCM at 0°C produced the rearranged chloride **1.50**. This rearrangement involves concerted nucleophilic attack of the chloride anion at the benzylic carbon of aziridinium intermediate.<sup>88</sup> Cyclization of chloride **1.50** was next affected by treatment with LiHMDS in THF at -78°C to afford 2-cyano azetidines **1.51** and **1.52** as a 3:7 mixture of stereoisomers at C(2). Hydrolysis of 2-cyano azetidine **1.52** by using concentrated HCl (35% wt.), followed by debenylation of the corresponding hydrochloride salt with Pd/C,

and purification by ion exchange chromatography, yielded 3-phenyl Aze **1.53** that can be considered as a conformationally constrained analog of phenylalanine (Scheme 1.12).

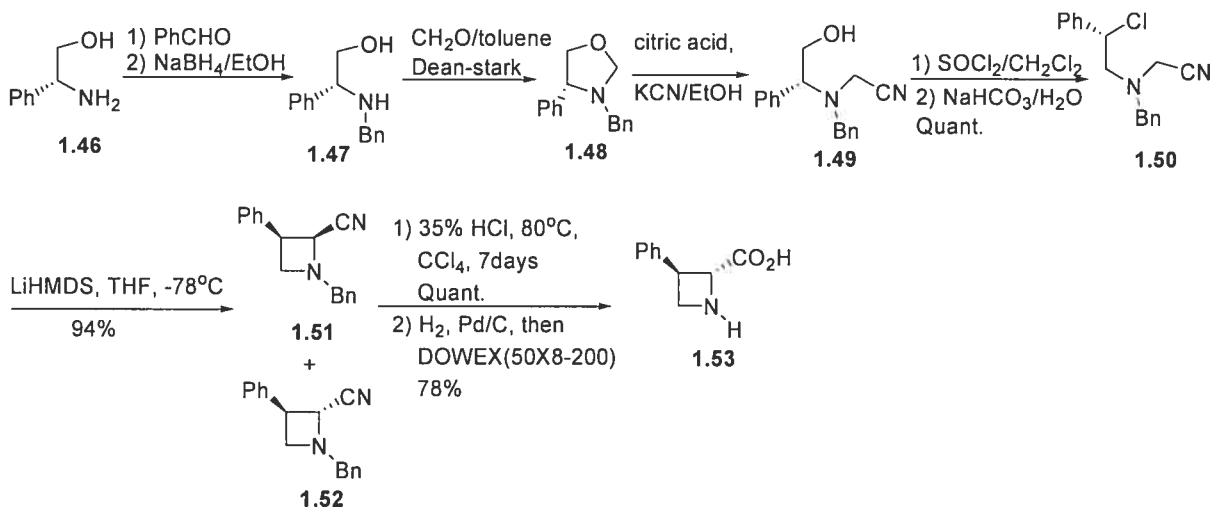

Scheme 1.12: Synthesis of enantiopure 3-phenyl Aze **1.53** as a phenylalanine chimera.

#### 1.4.1.6 Asymmetric synthesis of 3-substituted Aze employing SAMP/RAMP methodology:

Very recently Enders *et al.* reported the preparation of substituted azetidine type  $\alpha$ - and  $\beta$ -amino acids via 1,3-amino alcohols by employing SAMP/RAMP-hydrazone methodology.<sup>89</sup> The SAMP/RAMP hydrazones **1.54** were hydroxymethylated by  $\alpha$ -alkylation with (2-trimethylsilyloxy)methyl chloride (SEMCl). The phenyl substituent was introduced by nucleophilic 1,2-addition of phenylcerium reagent to the C=N double bond of hydrazones **1.55**. The hydrazines **1.56** were directly submitted to a reductive N-N bond cleavage to remove the chiral auxiliary. Tosylation of O-protected amino alcohols with toluene sulfonyl chloride in the presence of  $\text{K}_2\text{CO}_3$  at reflux yielded N,O-protected

amino alcohol **1.57**. The amino alcohols **1.58** were cyclized under Mitsunobu conditions and the corresponding *N*-tosylated 2-phenylazetidines **1.59** were obtained as one diastereomer without racemization in good yields. Conversion of 2-phenylazetidines **1.59** to the corresponding  $\alpha$ -amino acids was accomplished by catalytic oxidation with ruthenium tetroxide in a biphasic solvent system  $\text{CH}_3\text{CN}$ ,  $\text{H}_2\text{O}$  and  $\text{CCl}_4$ . Detosylation with sodium naphthalene gave the free  $\alpha$ -amino acid **1.60** (Scheme 1.13).<sup>90</sup>

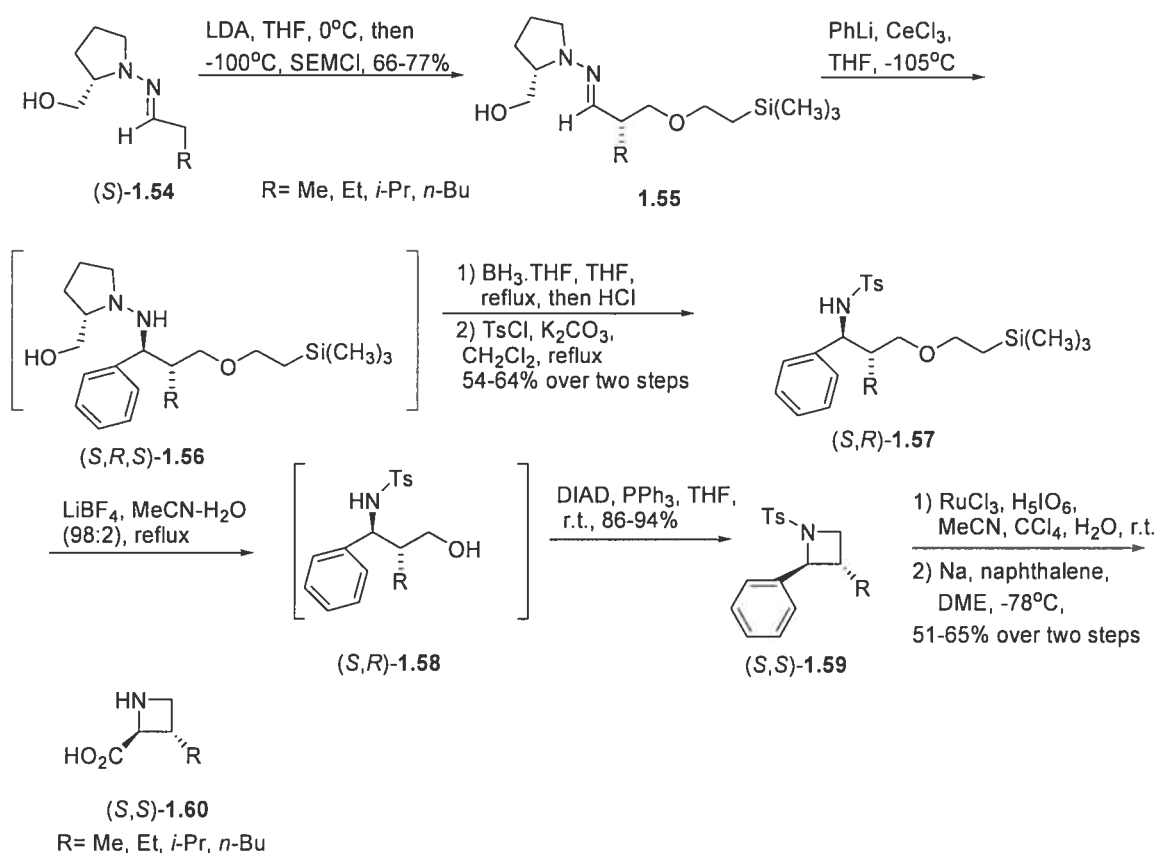

Scheme 1.13: Synthesis of 3-substituted Aze by employing SAMP/RAMP-hydrazone methodology.

## 1.4.2 Synthesis of 4-substituted azetidine-2-carboxylic acids

### Introduction:

4-substituted azetidine 2-carboxylic acids with one or two carboxy groups have been found in natural products<sup>91</sup> and rigid glutamate analogues with metabotropic receptor activity.<sup>84</sup> For example, *cis*-2,4-azetidine dicarboxylic acid is a nonproteinogenic amino acid that has been reported as a neurotransmitter potentiator.<sup>92,93</sup> Red-mold rice is effective in decreasing blood pressure<sup>94</sup> and lowering plasma cholesterol levels<sup>95</sup> and has antibacterial activity.<sup>96</sup> Recently, (+)-monascumic acid **1.61** and (-)-monascumic acid **1.61** were isolated from red-mold rice (Figure 1.11).<sup>94</sup>

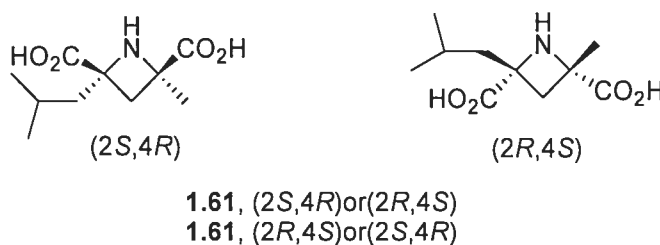

Figure 1.11: Structures of *cis*-2,4-azetidine dicarboxylic acid from extracts of red-mold rice.

Moreover, 2,4-disubstituted azetidines with hydroxymethyl groups have been used as chiral auxiliaries<sup>97</sup> and catalysts<sup>98</sup> for asymmetric synthesis, and have been prepared from the corresponding 2,4-azetidine dicarboxylic acids.<sup>99</sup>

### 1.4.2.1 Synthesis of 4-trifluoromethylated azetidine -2-carboxylic acid:

A diastereoselective synthesis of 4-trifluoromethylazetidine-2-carboxylic acid **1.67** was accomplished by the Wittig reaction of 4-trifluoromethyl  $\beta$ -lactam **1.63** followed by hydrogenation and functional group transformations.<sup>100</sup> 4-Trifluoromethyl- $\beta$ -lactam **1.63**

was prepared from the commercially available  $\beta$ -amino acid **1.62**. Without purification, the lactam was treated with  $(\text{Boc})_2\text{O}$  in the presence of 10% mol DMAP to afford *N*-Boc-protected  $\beta$ -lactam **1.63** in 25% overall yield from acid **1.62**. The Wittig reaction with ylide and lactam **1.63** in toluene at reflux afforded enamine **1.64**. Hydrogenation of the C=C bond of enamide ester **1.64** over Pd/C in ethyl acetate afforded exclusive *cis*-2,4-substituted azetidine **1.65** in 92% yield. 4-trifluoromethylazetididin-2-yl olefin **1.66** was prepared from ester **1.65** in 3 steps by ester hydrolysis, carboxylate reduction via a mixed anhydride and elimination of the primary alcohol. Subsequent oxidation of olefin **1.66** to the carboxylic acid **1.67** was accomplished using  $\text{NaIO}_4/\text{RuCl}_3$  in 80% yield (Scheme 1.14).

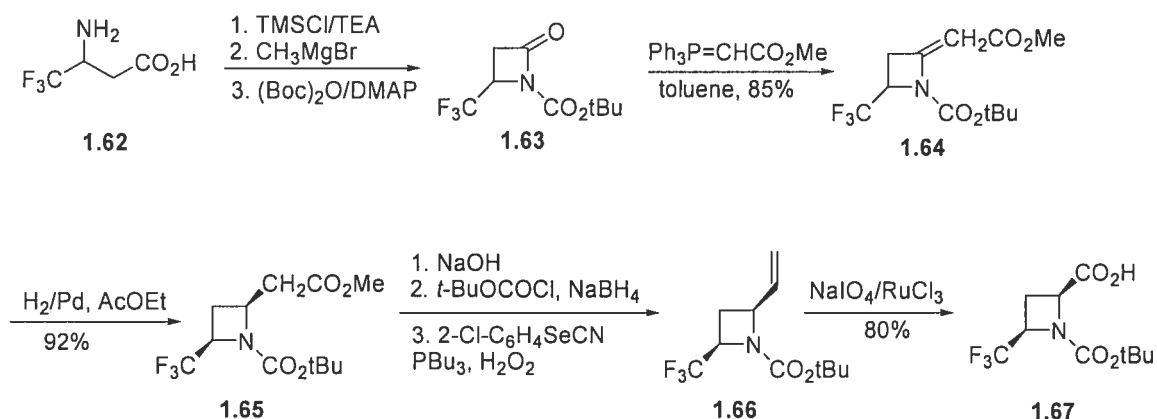

Scheme 1.14: Synthesis of *N*-Boc-4-trifluoromethyl Aze.

#### 1.4.2.2 Selective azetidine formation via Pd-catalyzed cyclizations of allen-substituted amines and amino acids:

4-Substituted Aze analog **1.73** was obtained in enantiomerically enriched form by enzymatic resolution of  $\omega$ -allenyl amino acid **1.70** followed by Pd-catalyzed ring

annulation (Scheme 1.15).<sup>101</sup> The hydrochloride salt of allenyl amino ester **1.69** was synthesized via alkylation of the glycine-derived ketimine **1.68** with 4-bromo-1,2-butadiene, followed by acid hydrolysis of the imine. Reaction of the ester with aqueous ammonia afforded the amino amide **1.70**. Enzymatic resolution of the (*S*)-amide **1.70** with *P.putida* ATCC 12633 provided the (*S*)- acid **1.71** in 82% ee. Subsequently, the (*R*)-amide was hydrolyzed with *RH. erthropolis* NCIB 11540 to provide (*R*)-**1.71** in 98% ee. Application of different cyclization conditions using Pd(PPh<sub>3</sub>)<sub>4</sub>, and K<sub>2</sub>CO<sub>3</sub>, with alkenyl or aryl halides, and triflates in DMF lead to different ratios of four and six membered rings (Scheme 1.15).



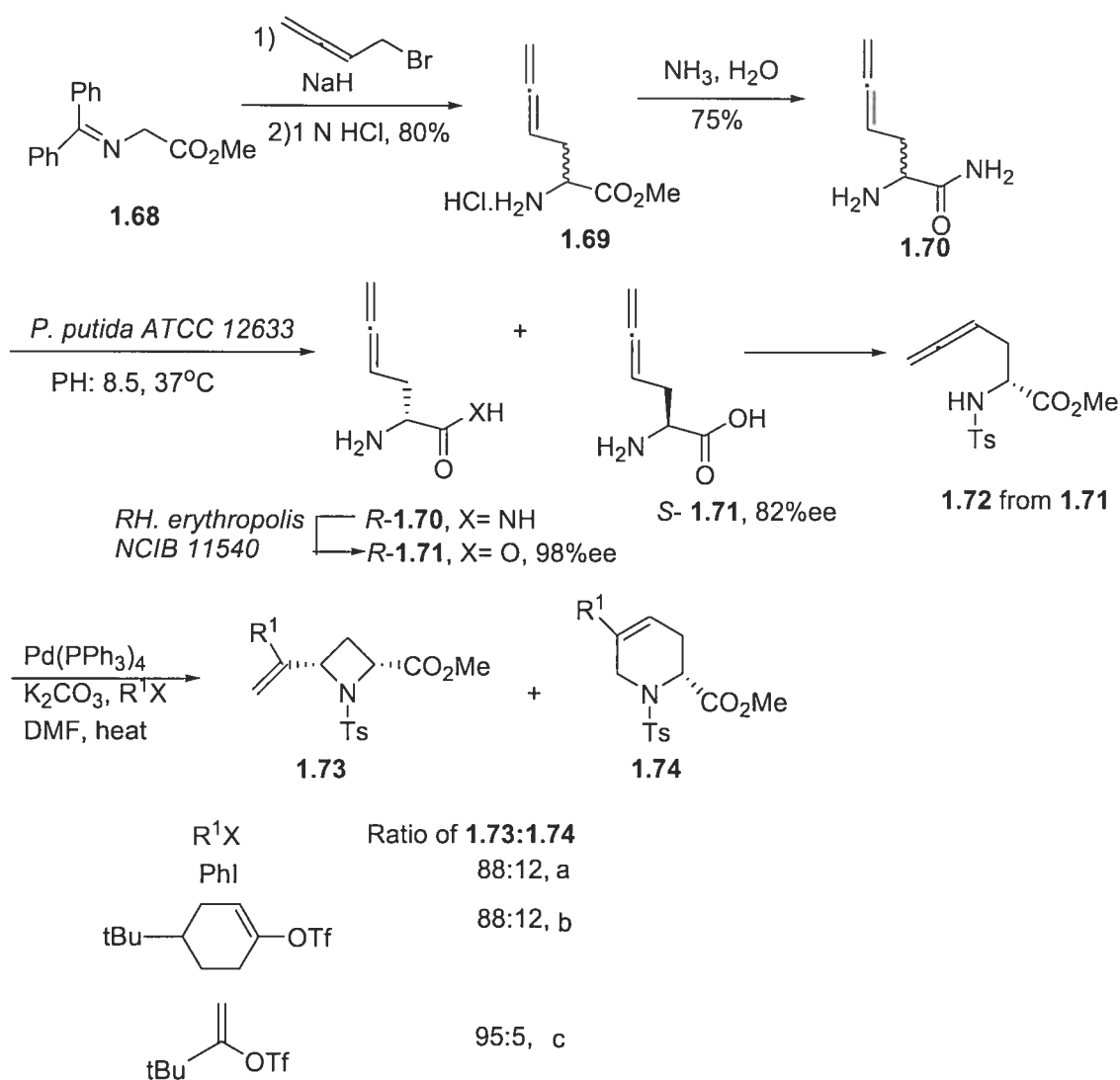

Scheme 1.15: Azetidine formation via Pd-catalyzed cyclization

### 1.4.2.3 Synthesis of azetidine-2,4-dicarboxylic acid

A diastereoisomeric mixture of azetidine 2,4-dicarboxylate **1.76** was synthesized by heating dimethyl 2,4-dibromopentanedioate **1.75** with (*S*)-1-phenylethylamine in toluene containing aqueous potassium carbonate (Scheme 3.3). Three components (*S,S*)-**1.76** (22%), (*R,R*)-**1.76** (22%) and *cis*-**1.76** (44%) were separated by flash chromatography.

Hydrogenolysis of diester (*S,S*)-**1.76** over palladium hydroxide on carbon followed by hydrolysis in hot water afforded (*2S,4S*)-azetidine-2,4-dicarboxylic acid **1.77** (Scheme 1.16).<sup>97, 102</sup> The (*R,R*)-isomer was also prepared by the same reaction sequence from diester (*R,R*)-**1.76**.

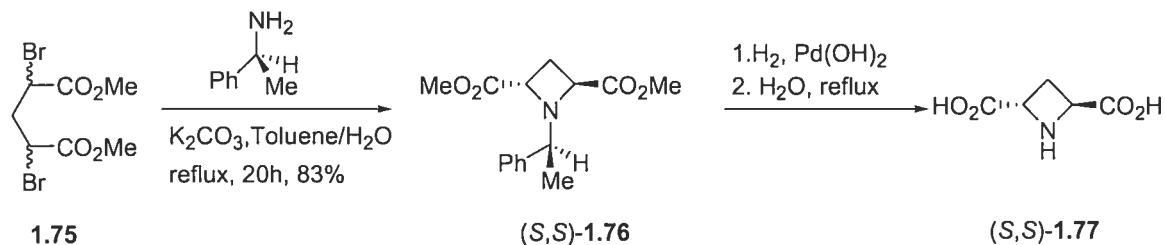

Scheme 1.16: Synthesis of azetidine-2,4-dicarboxylates.

#### 1.4.2.4 Synthesis of 4-substituted Aze via Wittig reaction of monocyclic lactams:

Substituted 2-exo-methylene azetidines were synthesized by a Wittig reaction on  $\beta$ -lactam **1.78** (Scheme 1.17). The resulting compounds were subjected to a range of ylides. Substituted 2-exo-methylene azetidines **1.79** were prepared using stabilized ylides. The unstabilized ylides or Horner-Emmons reagents led only to decomposition of starting material.<sup>103</sup>

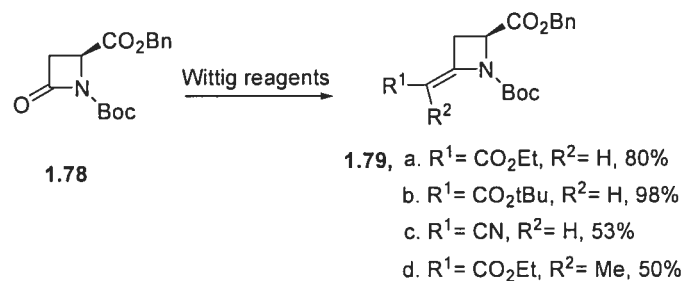

Scheme 1.17: Synthesis of 4-olefin Aze via Wittig reaction of monocyclic lactams

Excluding the intensely studied  $\beta$ -lactams, few syntheses of substituted azetidines have been reported. The reported yields of Aze analogues have been typically poor. Methods for synthesizing substituted Aze are also limited by the availability of the starting materials and cannot claim wide applicability. Therefore, the synthesis of substituted Aze remains a challenging problem for which new methodology is required.

## 1.5 References:

- 1) Adessi, C.; Soto, C. *Current Med. Chem.* **2002**, *9*, 963.
- 2) Ahmed, B., Kastin, A., J.; Banks, W. A.; Zadina, J.E. *Peptides*, **1994**, *15*, 1105.
- 3) Bonner, G.G.; Davis, P.; Stropova, D.; Fergosen, R.; Yamamura, H.I.; Porreca, F.; Hruby, V.J. *Peptides* **1997**, *18*, 93.
- 4) Hruby, V.J.; Hadley, M.E. In *Design and Synthesis of Organic Molecules Based on Molecular Recognition*; G. VanBinst, Ed.; Springer-Verlag: Heidelberg, **1986**; pp.269-289.
- 5) Branden, C.; Tooze, J. *Introduction to protein structure*; 2nd Eds. New York, Garland Publishing, Inc. **1991**; pp. 3-21.
- 6) Giannis, A.; Rubsam, F. *Adv. Drug. Res.* **1997**, *29*, 1-78.
- 7) Marx, V. *Chem. Eng. News* **2005**, March, 17-24.
- 8) Goodman, M.; Ro, S. *Burger's Medicinal Chemistry and Drug Discovery*, Vol.1 (Eds. M. E. Wolf), New York, John Wiley & Sons.Inc., **1995**, pp. 803-61.
- 9) Cornille, F.; Slomczynska, U.; Smythe, M. L. ; Beusen, D.D.; Moeller, K.D.; Marshall, G. R. *J. Am. Chem. Soc.* **1995**, *117*, 909-917.
- 10) Hruby, V.J.; Gerhrig, A. *Med. Res. Rev.* **1989**, *9*, 343-401.
- 11) Verdini, A. S.; Silvestri, S.; Becherucci, C.; Longobardi, M.G.; Parente, L.; Peppoloni, S.; Perretti, M.; Pileri, P.; Pinori, P. *J. Med. Chem.* **1991**, *34*, 3372.
- 12) Brazeau, P.; Vale, W.; Burgus, R.; Guillemin, R. *Can. J.Biochem.* **1974**, *52*, 1067.
- 13) Hirschmann, R., Nicolaou, K. C.; Pietranico, S.; Leahy, Salvino, K. C.; Arison, B.; Cichy, M. A.; Spoons, P. G.; Shakespeare, W. C. *J. Am. Chem. Soc.* **1993**, *115*, 12550.
- 14) Gante, J. *Angew. Chem. Int. Ed. Eng.* **1994**. *33*, 1699-1720.

- 15) Giannis, A.; Kolter, T. *Angew. Chem. Int. Ed. Eng.* **1993**, *32*, 1244-1267.
- 16) Manavalan, P.; Momany, F.A. *Biopolymers* **1980**, *19*, 1943
- 17) Kawai, M.; Fukuta, N.; Ito, N.; Kagami, T.; Butsugan, Y.; Maruyama, M.; Kudo, Y. *Int. J. Peptide Protein Res.* **1990**, *35*, 452.
- 18) Filatova, M.P.; Dri, N. A.; Orfkkchovich, O.M.; Reiss, V. M.; Liepinya, I.T.; Nikiforovich, G. V. *Bioorg. Khim.* **1986**, *12*, 59.
- 19) Bovy, P.R.; Trapani, A.J.; McMahon, E.G.; Palomo, M. *J. Med. Chem.* **1989**, *32*, 520.
- 20) Boteju, L. W.; Zalewska, T.; Yamamura, H.I.; Hruby, V.J. *J. Bioorg. Med. Chem. Lett.* **1993**, *3*, 2011.
- 21) Karle, I. L.; Balaram, P. *Biochemistry* **1990**, *29*, 6747.
- 22) Balaram, P.; Sudha, , T. S. *Int. J. Peptide Protein Res.* **1983**, *21*, 381.
- 23) Hruby V. J. *Nature*, **2002**, *1*, 847.
- 24) Samanen, J. ; Cash, T. ; Narindray, D. ; Brandeis, E. ; Adams, J. W.; Weideman, H.; yellin, T. *J. Med. Chem.* **1991**, *34*, 3036.
- 25) London, R. E.; Stewart, J. M.; Cann, J. R. *Biochem. Pharmacol.* **1990**, *40*, 41.
- 26) Barazza, A.; Witelsberger A.; Fiori, N.; Schievano, E.; Mammi, S.; Toniolo, C.; Alexander, M.; Rosenblatt, M.; Peggion, E.; Chorev, M. *J. Peptide Res.* **2005**, *65*, 23.
- 27) Gill, T. J.; Hanna, J. G.; Doty, P. *Nature*, **1963**, *197*, 746.
- 28) Sawyer, T. K.; Hruby, V. J.; Darman, P. S.; Hadley, M. E. *Proc. Natl Acad. Sci.* **1982**, *79*, 175.
- 29) Fu, Y; Bieschke, J.; Kelly, J. W. *J. Am. Chem. Soc.* **2005**, *127*, 15366.
- 30) Hruby, J. V. *Life Sci.* **1982**, *31*, 189.

- 31) Hruby, J. V.; Al-Obeidi, F. Kazmierski, W. M. *Biochemical J.* **1990**, 268, 249.
- 32) Abell, A. D.; Gardiner, J. *J. Org. Chem.* **1999**, 64, 9668.
- 33) Wu, W. J.; Raleigh, D. P. *J. Org. Chem.* **1998**, 63, 6689, and references cited therein.
- 34) Genin, M. J.; Gleason, W. B.; Johnson, R. L. *J. Org. Chem.* **1993**, 58, 860.
- 35) Boto, A.; Hernandez, R.; Suarez, E. *Tetrahedron Lett.* **2000**, 41, 2899.
- 36) Swarbrick, M. E., Gosselin, F.; Lubell, W. D. *J. Org. Chem.* **1999**, 64, 1993.
- 37) Rajashankar, K. R.; Ramakumar, S.; Chauhan, V. S. *J. Am. Chem. Soc.* **1992**, 114, 9225.
- 38) Hruby, V. J., Balse, P.M. *Current Med. Chem.* **2000**, 7, 945.
- 39) Ding J.; Russell, K.C.; Hruby, V. J. *Tetrahedron*, **1993**, 49, 3511
- 40) Eliel, E. L.; Manoharan, M.; Angelita N. *J. Org. Chem.* **1995**, 50, 16, 4978.
- 41) Hanessian, S.; Mc Naughton-Smith, G.; Lombart, H.-G; Lubell, W.D. *Tetrahedron*, **1997**, 53, 12789.
- 42) Karle, I. K.; Kaul, R.; Rao, R. B.; Raghothama, S.; Balaram, P. *J. Am. Chem. Soc.* **1997**, 119, 12048.
- 43) Holaday, M. W.; Lin, C. M.; May, C. S.; Gravey, D. S; Witte; D. G.; Miller, T. R.; Nazdan, A. M. *J. Med. Chem.* **1991**, 34, 455.
- 44) Quancard, J.; Labonne, A.; Jacquot, Y.; Chassaing, G. ; Lavielle, S. ; Karoyan, P. *J. Org. Chem.* **2004**, 69, 7940.
- 45) Sharma, R.; Lubell, W. D. *J. Org. Chem.* **1996**, 61, 202 and references 1-9 cited therein.
- 46) a) Evans, M. C.; Johnson, R. L. *Tetrahedron* **2000**, 56, 9801. b) Genin, M. J.; Gleason, W. B.; Johnson, R. L. *J. Org. Chem.* **1993**, 58, 860.

- 47) a) Gante, J. *Angew. Chem. Int. Ed. Engl.* **1994**, *33*, 1699. b) Boto, A.; Hernandez, R.; Suarez, E. *Tetrahedron Lett.* **2000**, *41*, 2899.
- 48) Mosberg, H. I.; Lomize, A. L.; Wang, C.; Kroona, H.; Heyl, D. L.; Sobczyk-Kojiro, K.; Ma, W.; Mousigian, C.; Porreca, F. *J. Med. Chem.* **1994**, *37*, 4371.
- 49) Souers, A.J.; Rosenquist, A.; Jarvie, E., M. ; Ladlow, M.; Fenuik, W. ; Ellman, J., A. *Bioorg. Med. Chem. Lett.* **2000**, *10*, 2731.
- 50) Fowden, L. *Nature* **1955**, *176*, 347.
- 51) Virtenan, A. *Nature* **1955**, *176*, 984.
- 54) Yeng, K.- F.; Lee, K.-M.; Woodward, R. W. *J. Nat. Prod.* **1998**, *61*, 207.
- 52) Fowden, L. *Biochemistry* **1955**, *64*, 323.
- 53) Fowden, L. *Biochem. J.* **1959**, *71*, 643.
- 54) Fowden, L.; Bryant, M. *Biochem. J.* **1958**, *70*, 626.
- 55) Zagari, A.; Nemethy, G.; Scheraga, H. A. *Biopolymers* **1990**, *30*, 951.
- 56) Zagari, A.; Nemethy, G.; Scheraga, H. A. *Biopolymers* **1990**, *30*, 967.
- 57) Deming, T. J.; Fournier, M. J.; Mason, T. L.; Tirrell, D. A. *Macromolecules* **1996**, *29*, 1442.
- 58) Schlechtingen, G.; Dehaven, R. N.; Daubert, J. D.; Cassel, J.; Goodman, M. *Biopolymers* **2003**, *71*, 71.
- 59) Reese, L. M.; Culter, K. O.; Deutch, C.E. *Lett. Appl. Microbil.* **1996**, *22*, 202.

- 60) Yokota, S., Yanagi, H.; Yura, T. ; Kubota, H. *Eur. J. Biochem.* **2000**, *267*, 1658.
- 61) Corey, E. J.; Helal, C. J.; *Angew. Chem. Int. Ed.* **1998**, *37*, 1986.
- 62) Yamaguchi, M.; Shiraiski, T.; Hiramata, M. *J. Org. Chem.* **1996**, *61*, 3520.
- 63) Starmans, W. A. J. Thijs, L.; Zwanenberg, B. *Tetrahedron* **1998**, *54*, 629.
- 64) Starmans, W. A. J.; Walgers, R. W.; Thijs, L.; de Gelder, R.; Smits, J. M. M.; Zwanenberg, B. *Tetrahedron* **1998**, *54*, 4991.
- 65) Fushiya, S.; Tamura, T.; Tashiro, T.; Nozoe, S. *Heterocycles* **1984**, *22*, 1039.
- 66) Noma, M.; Noguchi, M.; Tamaki, E. *Tetrahedron Lett.* **1971**, *27*, 2017.
- 67) Shioiri, T., Masuum, F.; Hamada, Y. *Pure Appl. Chem.* **1994**, *66*, 2151.
- 68) Akihisa, T.; Mafune, S.; Ukiya, M.; Kimura, Y.; Tasukawa, K.; Suzuki, T., Tokuda, H., Tanabe, N.; Fukuoka, T. *J. Nat. Prod.* **2004**, *67*, 479.
- 69) Holladay, M.W.; Decker, M. W. *Adv. Med. Chem.* **2000**, *5*, 85.
- 70) Gustafsson, D.; Nystrom, J. -E.; Carlsson, S.; Bredberg, U.; Erikson, U.; Nagard, S.; Abrahamsson, A.; Blyund, R. *Thrombosis Res.* **2001**, *101*, 171.
- 71) Kern, D.; Schukowski; Drakenberg, T. *J. Am. Chem. Soc.* **1997**, *119*, 8403 and references cited there in.
- 72) Dummy, P.; Keller, H.; Rayan, D. E.; Rohwedder, B.; Wohr T.; Mutter, M. *J. Am. Chem. Soc.* **1997**, *119*, 918.
- 73) Fowden, L. *Biochem. J.* **1956**, *64*, 323.



- 74) Yamada, Y.; Emori, T.; Kinoshita, S.; Okada, H. *Agr. Boil. Chem.* **1973**, *37*, 649.
- 75) Rodebaugh, R. M.; Cromwell, N. H. *J. Heterocycle Chem.* **1968**, *5*, 309.
- 76) Rodebaugh, R. M.; Cromwell, N. H. *J. Heterocycle Chem.* **1969**, *6*, 435.
- 77) Rodebaugh, R. M.; Cromwell, N. H. *J. Heterocycle Chem.* **1969**, *6*, 993.
- 78) Wasserman, H.H.; Lipshutz, B. H.; Tremper, A.W.; Wu, J.S. *J. Org. Chem.* **1981**, *46*, 2991.
- 79) Starmans, W. A.; Doppen, R.G.; Zwanenburg, B. *Tetrahedron: Asymm.* **1998**, *9*, 429.
- 80) Leete, E. *J. Am. Chem. Soc.* **1964**, *86*, 3162.
- 81) Miyoshi, M.; Sugano, H.; Fujii, T.; Ishibara, T.; Yoenda, N. *Chem. Lett.* **1973**, *5*, 415.
- 82) Couty, F. Evano, G.; Vargas-Sanchez, M.; Bouzas, G. *J. Org. Chem.* **2005**, *70*, 9028.
- 83) Hanessian, S.; Bernstein, N.; Yang, R-Y.; Maguine, R. *Bioorg. Med. Chem. Lett.* **1999**, *64*, 4362.
- 84) a) Kozikowski A. P.; Liao, Y.; Tuckmentel, W.; Wang, S.; Pshenikin, S.; Surin, A.; Thomsen, C.; Wroblewski, J.T. *Bioorg. Med. Chem. Lett.* **1996**, *6*, 2559. b) Kozikowski, W.; Tuckmantel, W.; Liao, Y.; Manev, H.; Ikonovic, S.; Wroblewski, J.T. *J. Med. Chem.* **1993**, *36*, 2706.
- 85) Wessig, P.; Schwarz, J. *Helvetica, Chim. Acta* **1998**, *81*, 1803.
- 86) Kawahata, N.; Weisberg, M.; Goodman, M.; *J. Org. Chem.* **1999**, *64*, 4362.
- 87) Couty, F.; Evano, G.; Rabasso, N. *Tetrahedron: Asymm.* **2003**, *14*, 2407.
- 88) Agami, C.; Couty, F.; Evano, G. *Tetrahedron: Asymm.* **2002**, *13*, 297.

- 89) Review; Job, A.; Janek, C. F.; Bettray, W.; Peters, R.; Enders D. *Tetrahedron* **2002**, 58, 2253.
- 90) Enders, D.; Gries, J. *Synthesis* **2005**, 20, 3508.
- 91) Seebach, D.; Vettiger, T.; Muller, H. -M.; Plattner, D. A.; Petter, W. *Justus Liebigs Ann. Chem.* **1990**, 687-695 and references therein.
- 92) Kozikowski, W.; Tuckmantel, W.; Liao, Y.; Manev, H.; Ikonovic, S.; Wroblewski, J.T. *J. Med. Chem.* **1993**, 36, 2706.
- 93) Kozikowski, W.; Tuckmantel, I.; Raynolds, J.; Wroblewski, J., T. *J. Med. Chem.* **1990**, 33, 1561.
- 94) Akihisa, T.; Tokuda, H.; Yasukawa, K.; Kiyota, A.; Tanabe, N. *J. Agric. Chem.* **2005**, 53, 562.
- 95) Endo A. *J. Med. Chem.* **1985**, 28, 401.
- 96) Wong, H. C.; Ban, Y. S.; *Plant Physiol.* **1977**, 60, 578.
- 97) Hashino, J.; Hiraoka, J.; Hata, Y.; Sawada, S.; Yamamoto, Y. *J. Chem. Soc. Perkin Trans 1* **1995**, 693-697.
- 98) Rama Rao, A. V.; Gunjar, M. K.; Kaiwar, V. *Tetrahedron Asymm.* **1992**, 3, 859.
- 99) Guanti, G.; Riva, R. *Tetrahedron Asymm.* **1995**, 6, 2921.
- 100) Jiang, J.; Shah, H.; Devita, R. J. *Org. Lett.*, **2003**, 5, 4101.
- 101) Rutjes, F. P.; Tjen, Kim, C. M. F.; Wolf, L. B.; Karstenl, F. J.; Schomaker, H. E.; Hiemstra, H. *Org. Lett.* **1999**, 1, 717.
- 102) Hoshino, J.; Hirroka, Y.; Hata, Y.; Sawada, S.; Yamamoto, Y. *J. Chem. Soc. Perkin Trans. 1*, **1995**, 693.
- 103) Baldwin, J. E.; Edwards, A. J.; Farthing, C. N.; Russell, A. T. *Synlett* **1993**, 49-50.

## **CHAPTER 2**

**Article: Amino Acid-Azetidin Chimeras: Synthesis of Enantiopure 3-Substituted Azetidine-2-carboxylic Acids**

Sajjadi, Z; Lubell, W. D.

Published in: *J. Peptide. Res.* **2005**, *65*, 298-310.

## 2.1 Abstract

Azetidine 2-carboxylic acid (Aze) analogs possessing various heteroatomic side chains at the 3-position have been synthesized by modification of 1-PhF-3-allyl-Aze *tert*-butyl ester (2*S*,3*S*)-**2.1** (PhF = 9-(9-phenylfluorenyl)). 3-Allyl-Aze **2.1** was synthesized from a sequence commencing with regioselective allylation of  $\alpha$ -*tert*-butyl  $\beta$ -methyl *N*-(PhF)aspartate **2.13**, followed by selective  $\omega$ -carboxylate reduction, tosylation and intramolecular *N*-alkylation. Removal of the PhF group and olefin reduction by hydrogenation followed by Fmoc protection produced nor-Leucine-Aze chimera **2.2**. Regioselective olefin hydroboration of (2*S*,3*S*)-**2.1** produced primary alcohol **2.23**, which was protected as a silyl ether, hydrogenated and *N*-protected to give 1-Fmoc-3-hydroxypropyl-Aze **2.26**. Enantiopure (2*S*,3*S*)-3-(3-azidopropyl)-1-Fmoc-azetidine-2-carboxylic acid *tert*-butyl ester **2.3** was prepared as a Lys-Aze chimera by activation of 3-hydroxypropyl-Aze **2.26** as a methanesulfonate and displacement with sodium azide. Moreover, orthogonally protected azetidine dicarboxylic acid **2.4** was synthesized as an  $\alpha$ -amino adipate-Aze chimera by oxidation of alcohol **2.26**. These orthogonally protected amino acid-Aze chimeras are designed to serve as tools for studying the influence of conformation on peptide activity.

**Key words:** azetidine 2-carboxylic acid; azetidines; amino acid; chimera; heterocycle; peptide synthesis

## 2.2 Introduction

Conformationally constrained amino acids have been used as tools for studying peptide secondary structure and for developing peptide-derived pharmaceutical agents.<sup>1-4</sup> In particular, cyclic amino acids such as proline and its higher homologue pipercolic acid have been used to restrict the phi and psi dihedral angles of the peptide backbone to induce turn geometry.<sup>5,6</sup> Furthermore, the introduction of  $\beta$ -substituents onto proline and pipercolate has been used to create amino acid chimeras, which can restrict the side-chain orientations and backbone geometry of specific residues within a peptide to study the relationship between conformation and activity. For example, proline-amino acid chimeras have been used in place of natural amino acids in peptides to provide a better understanding of the bioactive conformations of G-protein coupled receptor (GPCR) ligands<sup>7-10</sup> and peptide-based enzyme inhibitors.<sup>11</sup>

Azetidine 2-carboxylic acid (Aze) has been used less often as a probe for studying peptide chemistry and biology. Aze has been incorporated *in vivo* and *in vitro* into cellular proteins of *Escherichia coli*<sup>12</sup> as well as in chick embryo<sup>13</sup> for studies on collagen biosynthesis,<sup>14</sup> in which replacement of Pro in collagen with as little as 4% of Aze was sufficient to destabilize triple-helix bundle formation. The study of Aze in polypeptides such as poly-L-Aze, has shown that peptides containing Aze are more flexible than the corresponding sequences containing Pro and that the tendency for  $\beta$ -bend formation is higher for Gly-Aze than for Gly-Pro dipeptides.<sup>15-18</sup> Introduction of Aze into a peptide containing three consecutive proline residues in a linear sequence perturbed the normal proline peptide secondary structure and the *cis-trans* amide isomer

equilibrium in Boc-(L-Pro)<sub>3</sub>-L-Aze-Opcp (pcp = pentachlorophenyl).<sup>19</sup> Replacement of Aze for proline in peptide analogs has also altered receptor selectivity.<sup>20</sup>

A component of biologically and pharmacologically important natural products and synthetic compounds, Aze is found in the polyoxin group of antifungal antibiotics,<sup>21</sup> nicotianamine,<sup>22</sup> mugineic acid<sup>23</sup> and red-mold rice fermentation products.<sup>24</sup> Among substituted azetidine carboxylic acid analogs, *cis*-azetidine-2,4-dicarboxylic acid has been reported as a neurotransmitter potentiator<sup>25,26</sup> and *trans*-2-carboxyazetidine-3-acetic acid (t-CAA) has been used as a rigid glutamic acid analog exhibiting effects such as inhibition of Na<sup>+</sup>-dependent Glu uptake and neuroexcitatory activity at the kainate receptor sub-type.<sup>26</sup>

In the context of our research on the effects of azacycloalkane amino acids on peptide conformation, we became interested in employing  $\beta$ -alkylazetidines as azetidine-amino acid chimeras for studying secondary structure. In light of its importance as a constituent of biologically active compounds, the development of methodology for synthesizing Aze analogs is merited; however, relative to proline and pipercolate analogs the synthesis of alkyl-substituted azetidine 2-carboxylic acid derivatives has received less attention. Few methods have offered the potential for selective and stereocontrolled introduction of alkyl substituents at the ring carbons. Earlier syntheses of racemic 2-azetidine carboxylic acids by resolution and by a series of transformations starting from homoserine have been reviewed.<sup>27-29</sup> Azetidine-2-carboxylic acids have been synthesized bearing substituents at the 1-<sup>30-37</sup>, 2-<sup>38-42</sup>, 3-<sup>21,43-50</sup> and 4-positions,<sup>51</sup> as well as with multiple substitution patterns.<sup>52-55</sup>

Synthesis of the azetidine ring is typically achieved by intramolecular cyclization of the open-chain compounds to form the C-N bond.<sup>27,56</sup> At the time of our investigation, we were aware of five methods for the synthesis of 3-substituted azetidine-2-carboxylates in enantiopure form. For example, 3-substituted L-azetidine 2-carboxylic acids possessing phenyl, naphthyl and isopropyl substituents at the 3-position were synthesized by Hanessian and co-workers using a general route featuring diastereoselective zinc-mediated additions of substituted allylic halides to the camphor sultam derivative of glyoxalic acid O-benzyl oxime, followed by a series of transformations to convert the linear  $\alpha$ -amino pentenamide product into the 3-aryl and 3-alkyl Aze derivatives **2.5-2.7** (Fig. 2.1).<sup>48</sup> Both *cis*- and *trans*-polyoximic acids were also synthesized by the Hanessian lab starting from D-serine as a chiral educt.<sup>21,46</sup> In addition, 3-acetic acid (*t*-CAA) and 3-propionic acid analogs **2.8** and **2.9** of Aze have been synthesized by allylation of a  $\beta$ -lactam enolate derived from D-aspartic acid and subsequent olefin oxidations and lactam reduction.<sup>26</sup>

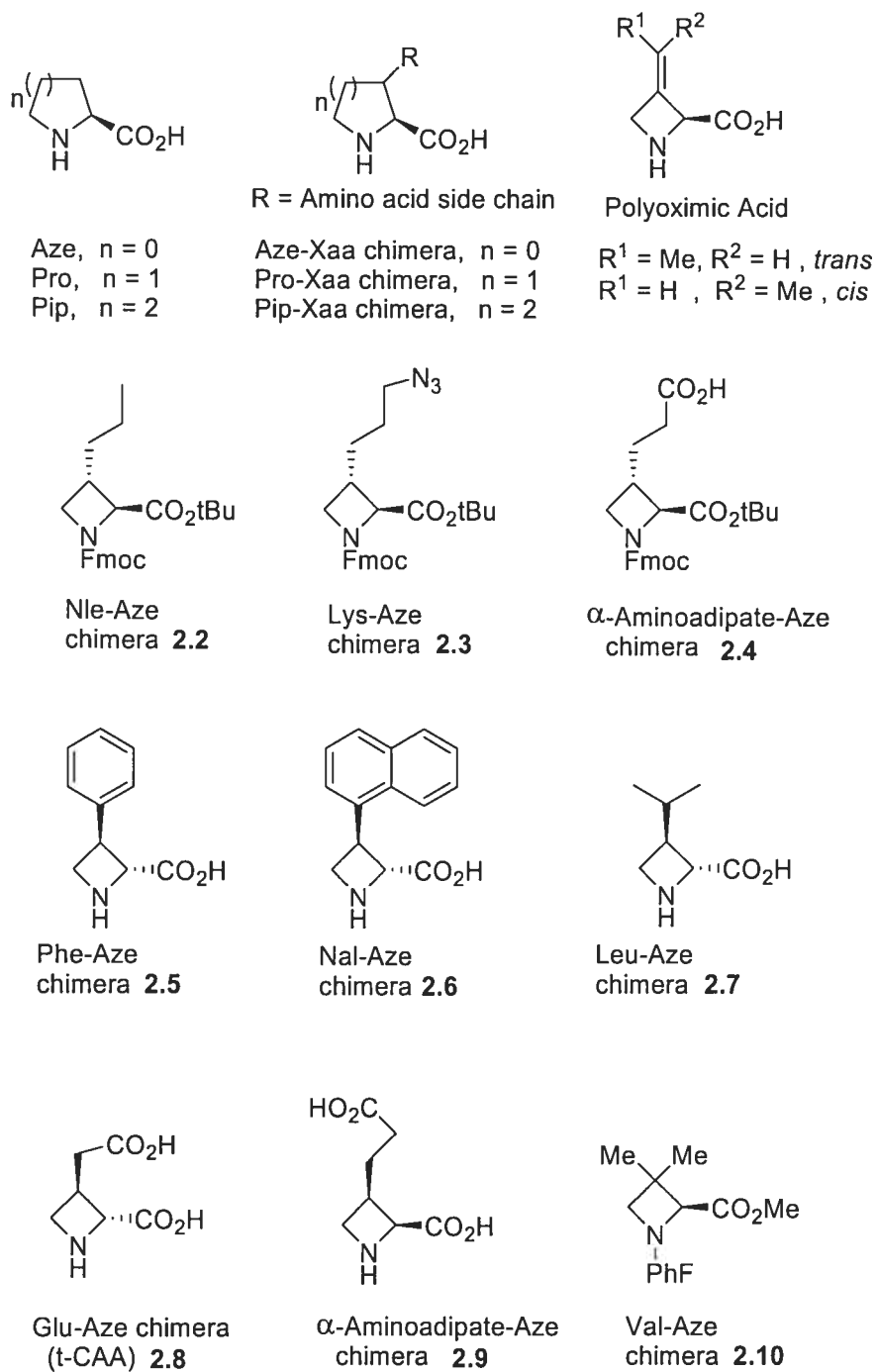

Figure 2.1: Representative Aze-Xaa amino acid chimeras.

Among the strategies for making 3-substituted Aze analogs, the synthesis of 3,3-dimethyl-Aze **2.10** by Goodman seemed practical,<sup>47</sup> because it employed N-



(PhF)aspartate dimethyl ester **2.11**, which could be prepared by regioselective alkylation using methodology introduced by Rapoport for the installation of various side-chain groups (57). 3,3-Dimethyl-Aze **2.10** was prepared from  $\beta,\beta$ -dimethyl aspartate **2.11** by regioselective reduction of the  $\beta$ -methyl carboxylate, activation of the resulting alcohol and intramolecular nucleophilic displacement (Fig. 2.2).<sup>47</sup>

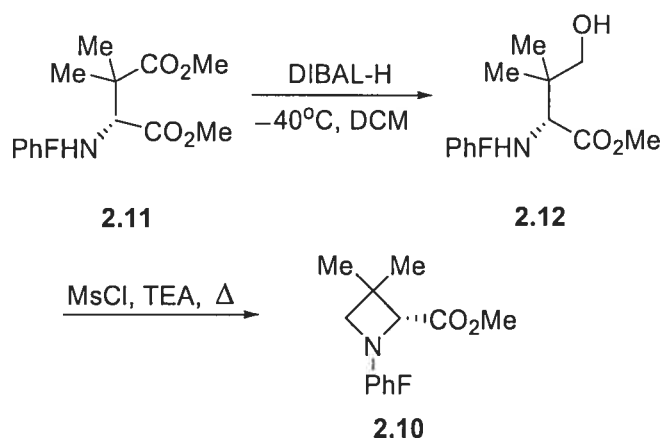

Figure 2.2: Synthesis of  $\beta,\beta$ -dimethyl-Aze by Goodman.<sup>47</sup>

Azetidine 2-carboxylic acids possessing heteroatomic side-chain substituents at the 3-position were thus targeted, using  $\alpha$ -*tert*-butyl  $\beta$ -methyl *N*-(PhF)aspartate **2.13** as a common intermediate. Regioselective enolization and alkylation of aspartate **2.13** was considered for introducing allyl substituents stereoselectively at the  $\beta$ -position.<sup>57,58</sup> (2*S*,3*S*)- and (2*S*,3*R*)-3-Allyl 1-PhF-Aze *tert*-butyl ester **2.1** were synthesized in 4 steps from  $\beta$ -allyl aspartate **2.19** by a route featuring selective  $\omega$ -carboxylate reduction and intramolecular *N*-alkylation (Fig. 2.4). (2*S*,3*S*)-Olefin **2.1** was subsequently used as a common intermediate for the synthesis of a series of azetidine-amino acid chimeras involving hydrogenation or hydroboration of the olefin to provide constrained nor-leucine-Aze chimera **2.2** and 3-hydroxypropyl-azetidine-2-carboxylate **2.23**, respectively

(Fig. 2.6). Conversion of PhF-azetidine **2.23** into its Fmoc counterpart **2.26**, activation of the hydroxyl group and displacement with azide gave Lys-Aze chimera **2.3** (Fig. 2.7). Oxidation of alcohol **2.26** provided  $\alpha$ -aminoadipate-Aze chimera **2.4**.

### 2.3 Results and discussion:

$\alpha$ -*tert*-Butyl  $\beta$ -methyl *N*-(PhF)aspartate **2.13** was synthesized in three steps on a 15 g scale from L-aspartic acid according to a literature method.<sup>59</sup> The parent amino acid, Aze was first prepared to compare the reactivity of dialkyl, monoalkyl and compounds lacking a substituent at the  $\beta$ -position during the cyclization step.  $\omega$ -Ester reduction with DIBAL-H in tetrahydrofuran (THF) at  $-40$  °C provided the corresponding homoserine **2.14** without lactone formation (Fig. 2.3).<sup>59</sup> Homoserine **2.14** was then converted to the corresponding tosylate **2.15** in 72% yield by using toluenesulfonyl chloride and pyridine in dichloromethane (DCM). Under these conditions, concurrent intramolecular ring closure occurred to provide azetidine **2.16** as an additional product in 16% yield after chromatography. In our hands, the intramolecular displacement was best effected using  $\text{Cs}_2\text{CO}_3$  in acetonitrile;  $\text{Na}_2\text{CO}_3$  in acetonitrile gave a slower reaction and lower yield. Fmoc-Aze-OtBu **2.18** was synthesized in two steps and 77% yield from *N*-PhF-Aze **2.16**. Hydrogenation of **2.16** at 8 atm of  $\text{H}_2$  using palladium-on-carbon as catalyst in 9:1 EtOH:AcOH gave the amino ester which was isolated as its HCl salt. The Fmoc group was then installed using FmocOSu and sodium bicarbonate in acetone/ $\text{H}_2\text{O}$  at room temperature.

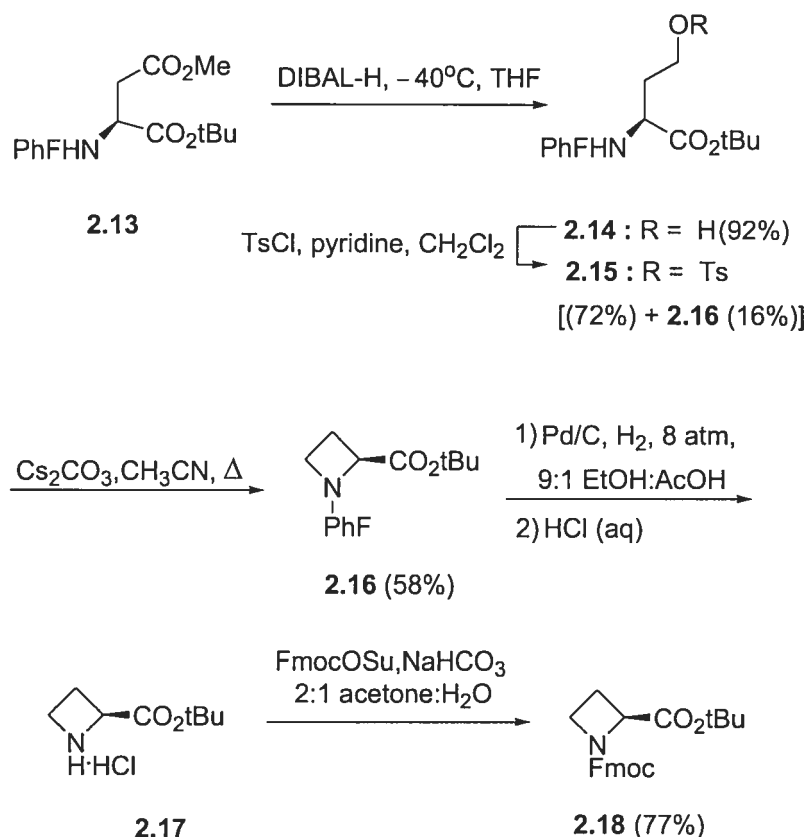

Figure 2.3: Synthesis of Fmoc-Aze-OtBu **2.18** from aspartate **2.13**.

3-Allyl-1-(PhF)-azetidine-2-carboxylic acid *tert*-butyl esters **2.1** were synthesized in a similar manner using  $\beta$ -allyl aspartate **2.19** (Fig. 2.4). Regioselective alkylation of  $\alpha$ -*tert*-butyl  $\beta$ -methyl *N*-(PhF)aspartate **2.13** was achieved using sodium bis(trimethylsilyl)amide (NaHMDS, 1M in THF) followed by reaction with allyl iodide, which produced a 3 : 2 mixture of diastereomers **2.19** in 96% yield after chromatography. The unseparated mixture of diastereomers were reduced with DIBAL-H in THF at  $-40^\circ\text{C}$  to provide homoserine diastereomers (2*S*,3*R*)- and (2*S*,3*S*)-**2.20** in 91% yield after chromatography. The mixture of diastereomeric alcohols was separated by performing a second chromatography using toluene-isopropylether (8 : 2) as eluant. Tosylation and intramolecular displacement of (2*S*,3*R*)- and (2*S*,3*S*)-**2.20** were performed as described

for the parent system using toluenesulfonyl chloride and pyridine in DCM and afforded the corresponding tosylates **2.21**, which were then heated with  $\text{Cs}_2\text{CO}_3$  in  $\text{CH}_3\text{CN}$  to provide (2*S*,3*R*)- and (2*S*,3*S*)-azetidine **2.1**, respectively.

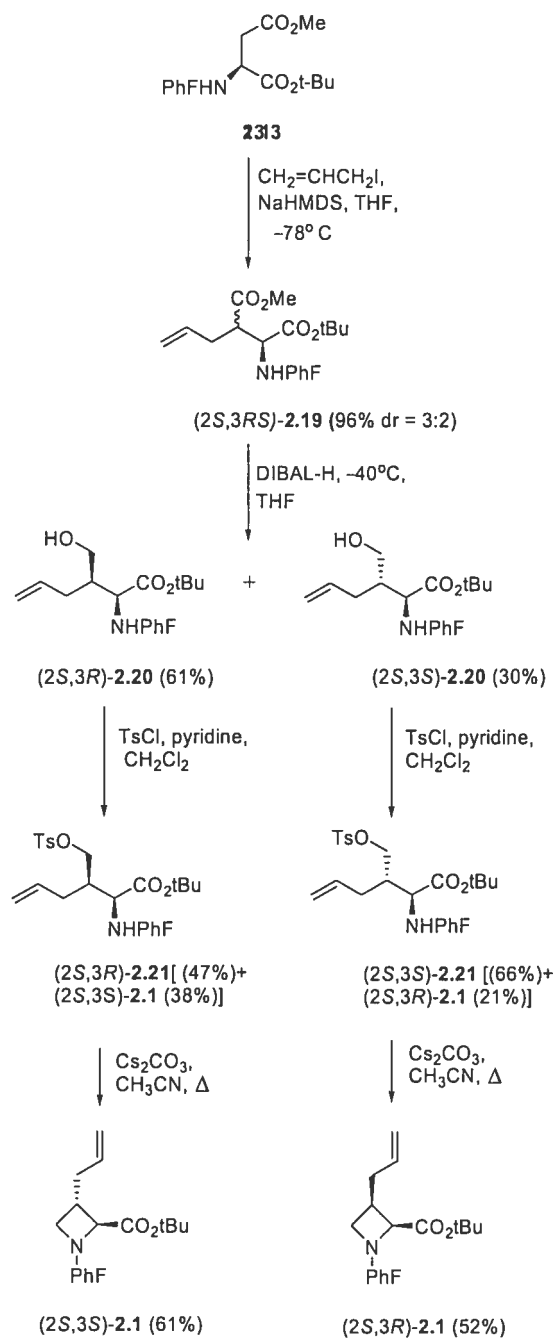

Figure 2.4: Synthesis of 3-Allyl 1-PhF-Aze (2*S*,3*S*)- and (2*S*,3*R*)- **2.1**

The configurations of the (2*S*,3*R*)- and (2*S*,3*S*)-3-allyl azetidines **2.1** from cyclization of the (2*S*,3*S*)- and (2*S*,3*R*)- tosylate diastereomers, respectively, were assigned based on their NOESY spectra in CHCl<sub>3</sub> (Fig. 2.5). Transfer of magnetization between the α-hydrogen and the allylic methylene protons indicated their *cis* relationship in (2*S*,3*S*)-**2.1**. The *trans* relationship between the allyl group and α-proton in (2*S*,3*R*)-**2.1** was indicated by their respective NOEs with the two different γ-protons.

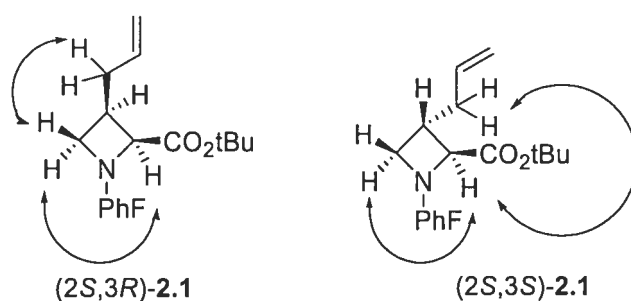

Figure 2.5: Long distance NOE correlations for the stereochemical assignments of (2*S*,3*R*)- and (2*S*,3*S*)-3-allyl-1-PhF-azetidine-2-carboxylates **2.1** (characteristic transfers of magnetization are written with double-tipped arrows).

Orthogonally protected nor-leucine-Aze chimera **2.2**, suitable for peptide synthesis, was prepared in two steps and 58% yield from β-allyl *N*-(PhF)Aze **2.1** (Fig. 2.6). Hydrogenation at 6 atm using palladium-on-carbon as catalyst in 9 : 1 EtOH : AcOH effected double bond reduction and cleavage of the phenylfluorenyl group. Installation of the Fmoc group was then accomplished using FmocOSu and sodium bicarbonate in acetone/H<sub>2</sub>O at room temperature.

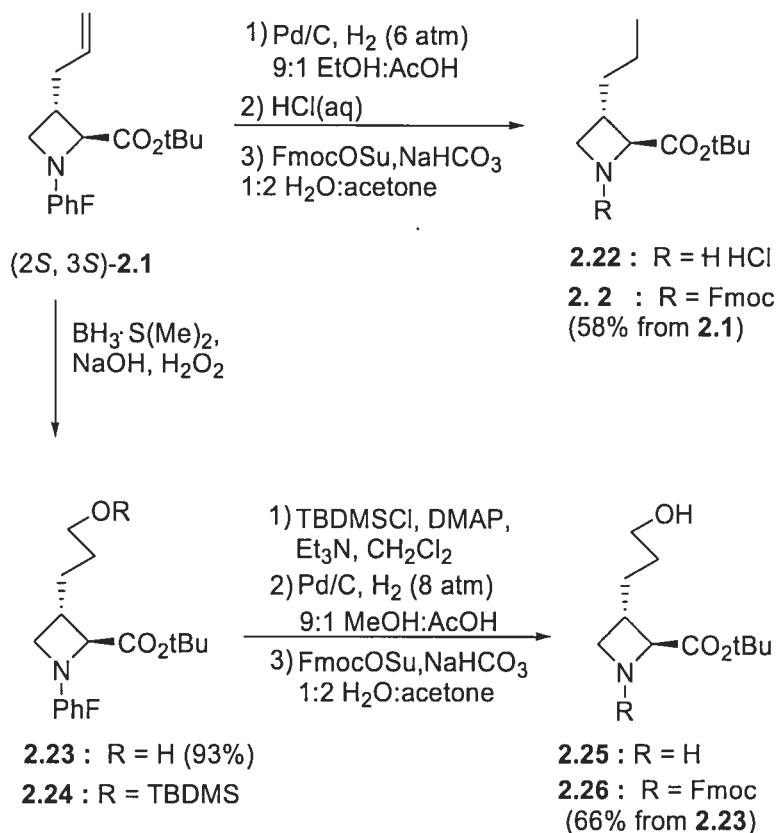

Figure 2.6: Reduction and hydroboration of olefin **2.1**; synthesis of Nle-Aze chimera **2.2**.

The elaboration of olefin **2.1** into a variety of heteroatom-containing side-chains was initiated by hydroboration and conversion to the corresponding 3-hydroxypropyl-Aze **2.23** (Fig. 2.6). Earlier attempts to prepare the primary alcohol using disiamyl borane<sup>60</sup> and 9-BBN in THF,<sup>61</sup> followed by treatment with NaOH and H<sub>2</sub>O<sub>2</sub>, were unsuccessful and starting material was recovered. Employing BH<sub>3</sub> as a less sterically bulky borane in THF produced a mixture of primary and secondary alcohols in low yield. Selective formation of primary alcohol **2.23** was achieved in 93% yield using borane dimethyl sulfide complex in THF followed by oxidative work-up.<sup>62</sup>

The exchange of the nitrogen protecting group from PhF to Fmoc was examined to later

facilitate oxidative and peptide chemistry. Several solvent systems were examined for the hydrogenolysis of primary alcohol **2.23** to remove the PhF group, such as 9 : 1 MeOH : AcOH, 9 : 1 EtOH : AcOH, and THF, using palladium-on-carbon under hydrogen atmosphere. However, unsatisfactory results were obtained. On the contrary, treatment of 3-hydroxypropyl-Aze **2.23** with TBDMSCl in the presence of DMAP and triethylamine gave 3-siloxypropyl-Aze **2.24**, which underwent hydrogenolytic cleavage of the PhF group in 9 : 1 MeOH : AcOH using palladium-on-carbon under 8 atm of H<sub>2</sub>. 1-Fmoc-3-Hydroxypropyl-Aze **26** was then prepared by treatment of the hydrogenation mixture with NaHCO<sub>3</sub> and FmocOSu in acetone/H<sub>2</sub>O at room temperature for 24 h, work-up and chromatography on silica gel.

Activation of *N*-Fmoc-3-hydroxypropyl **2.26** using methanesulfonyl chloride and triethylamine in dichloromethane gave methanesulfonate **2.27** in 80% yield after purification by chromatography (Fig. 2.7). Nucleophilic displacement of **2.27** with sodium azide in dimethylformamide (DMF) at 80 °C furnished azide **2.3** in 62% yield.  $\alpha$ -Amino adipate-Aze chimera **2.4** was finally synthesized in 90% yield by oxidation of 3-hydroxypropyl-Aze **2.26** with a cocktail of NaClO<sub>2</sub>, NaOCl and TEMPO in CH<sub>3</sub>CN.<sup>63</sup>

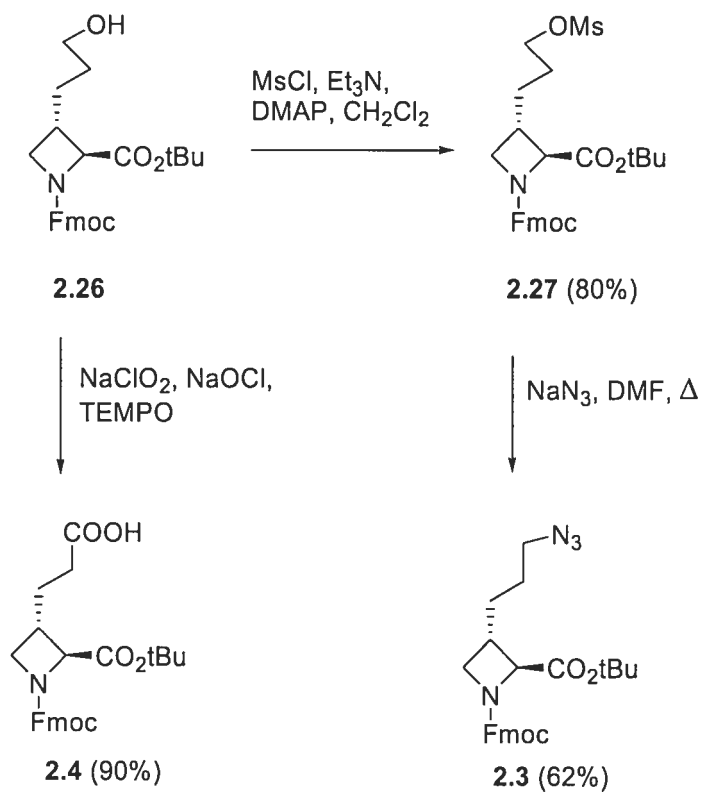

Figure 2.7: Synthesis of Lys-Aze and  $\alpha$ -Amonoadipate-Aze chimeras 2.3 and 2.4.



## 2.4 Conclusion:

A series of enantiopure amino acid-Aze chimeras possessing heteroatomic side-chains have been synthesized starting from aspartate diester **2.13** as an inexpensive chiral educt.  $\beta$ -Allylation of diester **2.13** followed by  $\omega$ -ester reduction, tosylation and intramolecular cyclization gave 3-allyl-1-PhF-Aze **2.1**. Olefin reduction and Fmoc-protection provided nor-leucine-Aze chimera **2.2**. Olefin hydroboration afforded the corresponding 3-hydroxypropyl-Aze **2.23** which was converted respectively to Lys-Aze and  $\alpha$ -aminoadipate-Aze chimeras **2.3** and **2.4** by routes featuring alcohol activation and displacement with azide ion and TEMPO-catalysed oxidation. We are currently exploring the introduction of these amino acid-Aze chimeras into peptides to study structure activity relationships.

## 2.5 Experimental Section

**General.** Unless otherwise noted, all reactions were run under nitrogen atmosphere and distilled solvents were transferred by syringe. Anhydrous tetrahydrofuran (THF), dichloromethane (DCM), acetonitrile (CH<sub>3</sub>CN) and dimethylformamide (DMF) were obtained from solvent filtration systems. Triethylamine (Et<sub>3</sub>N) and pyridine were distilled from ninhydrin and CaH<sub>2</sub>. Final reaction mixture solutions were dried over Na<sub>2</sub>SO<sub>4</sub> and rotary-evaporated under vacuum. Melting points are uncorrected. Mass spectral data, HRMS/ESMS, were obtained by the Université de Montréal Mass Spectrometry facility. Unless otherwise noted, <sup>1</sup>H NMR (300/400 MHz) and <sup>13</sup>C NMR (75/100 MHz) spectra were recorded in CDCl<sub>3</sub>. Chemical shifts are reported in ppm ( $\delta$ )

units) downfield of internal tetramethylsilane ((CH<sub>3</sub>)<sub>4</sub>Si) or residual solvent: CHCl<sub>3</sub> and MeOH. Coupling constants are reported in hertz (Hz). Chemical shifts of aromatic and vinylic carbons are not reported for the <sup>13</sup>C NMR spectra of PhF containing compounds. Analytical thin-layer chromatography (TLC) was performed using aluminum-backed silica plates coated with a 0.2 mm thickness of silica gel 60 F<sub>254</sub> (Merck KGaA Germany). Chromatography was performed using Kieselgel 60 (230-400 mesh).

**(2S)-tert-Butyl 2-[N-(PhF)Amino]-4-(toluenesulfonyloxy)-butyrate (2.15):**

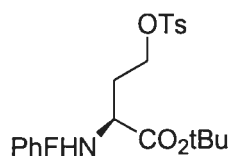

To a magnetically stirred solution of alcohol **2.14** (500 mg, 1.2 mmol, 100 mol %, prepared according to reference 59) and dry pyridine (1.2 ml) in dry CH<sub>2</sub>Cl<sub>2</sub> (12 ml) at 0 °C, solid *p*-toluenesulfonyl chloride (693 mg, 3.6 mmol, 300 mol %) was added in one portion. The mixture was stirred at 0 °C for 2 h and then at room temperature for 24h. The reaction mixture was poured into ice water and extracted with ethyl acetate (3 × 20 ml). The organic phases were combined, washed with brine, dried (MgSO<sub>4</sub>) and evaporated to a residue that was chromatographed using 5% EtOAc in hexanes as eluant. First to elute was azetidine **2.16** (77 mg, 16% yield) as a solid: m.p. 156.5-157.5 °C, spectral properties were identical to those reported below. Next to elute was tosylate **2.15** (496 mg, 72% yield) as white crystals: m.p. 106-107 °C; [α]<sub>D</sub><sup>20</sup> -184.3° (c 0.01; CHCl<sub>3</sub>). <sup>1</sup>HNMR δ: 1.21 (s,9 H), 1.51-1.62 (m,1 H); 1.72-1.82 (m,1 H); 2.47 (s,3 H); 2.52-2.55 (t,

$J = 5$  Hz, 1 H); 3.09 (s, 1 H); 4.03-4.10 (dd,  $J = 13.16$ ; 6.68 Hz, 1 H), 4.21-4.23 (dd,  $J = 16.1$ ; 7.1 Hz, 1 H); 7.20-7.85 (m, 17 H).  $^{13}\text{C}$  NMR  $\delta$  22.1; 28.1; 34.4; 53.1; 68.0; 73.2; 81.7; 174.44. ESMS  $m/z$  592.1 ( $\text{M}+\text{Na}$ ) $^+$ .

**(2S)-tert-Butyl 1-(PhF)-azetidine-2-carboxylate (2.16):**

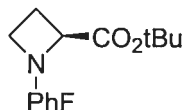

A vigorously stirred mixture of tosylate **2.15** (500 mg, 0.877 mmol, 100 mol%), and powdered  $\text{Cs}_2\text{CO}_3$  (430 mg, 1.31 mmol, 150 mol%) in 10 ml of acetonitrile was heated at reflux under argon for 19 h and evaporated. The residue was treated with ice-water (10 ml), and extracted with EtOAc (3  $\times$  20 ml). The combined organic phases were washed with brine, dried ( $\text{MgSO}_4$ ) and evaporated to a residue that was purified by chromatography using an eluant of 3% EtOAc in hexanes. Azetidine **2.16** (202 mg, 58% yield) was obtained as white crystals: m.p. 156.5-157.5  $^\circ\text{C}$ .  $[\alpha]_{\text{D}}^{20}$  38.5 $^\circ$  ( $c$  0.01,  $\text{CHCl}_3$ ).  $^1\text{H}$  NMR  $\delta$  1.13 (s, 9 H); 1.72-1.82 (m, 1 H); 2.03-2.15 (m, 1 H); 3.10-3.18 (dd,  $J = 15.6$ ; 8.2 Hz, 1 H), 3.25-3.36 (m, 2 H); 7.13-7.68 (m, 13 H).  $^{13}\text{C}$  NMR  $\delta$  20.8; 28.1; 46.7; 60.8; 76.5; 80.3; 172.4. ESMS  $m/z$  398.1 ( $\text{M}+\text{H}$ ) $^+$ . HRMS calcd. for  $\text{C}_{27}\text{H}_{27}\text{NO}_2$  ( $\text{M}+\text{H}$ ) $^+$  398.21146, found 398.21153.

**Azetidine-2-carboxylic Acid tert-Butyl Ester Hydrochloride (2.17):**

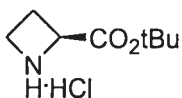

A solution of PhF-Aze **2.16** (322 mg, 0.81 mmol, 100 mol%) in 30 ml of EtOH:HOAc

(9:1) was transferred into a hydrogenation apparatus and treated with palladium-on-carbon (32 mg, 10 wt %). The pressure bottle was filled, vented, and refilled four times with hydrogen. The reaction mixture was stirred for 24 h at 6 atm of H<sub>2</sub>, filtered onto a plug of Celite<sup>R</sup> 521(Aldrich USA), and washed thoroughly with EtOH. The filtrate was treated with 1ml of 1N HCl and the volatiles were evaporated to give a crude residue (125 mg) that was used directly in the Fmoc protection without purification. <sup>1</sup>H NMR of crude **2.17**: δ 1.41 (s, 9 H); 2.56 (s, 1 H); 2.77 (s, 1 H); 4.15 (d, *J* = 37.2 Hz, 2 H); 4.75 (s, 1 H); 5.00 (s, 1 H). <sup>13</sup>C NMR δ 22.9; 27.9; 43.5; 57.5; 84.5; 166.9. ESMS *m/z* 157.9 (M)<sup>+</sup>

***tert*-Butyl 1-(Fmoc)-Azetidine-2-carboxylate (2.18):**

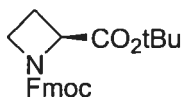

Fmoc-Aze **2.18** (295 mg, in 77% yield) was synthesized from Aze **2.17** (147 mg, 0.93 mmol) using the general Fmoc protection protocol described below and purified by chromatography using an eluant of 3-11% EtOAc in hexanes. Evaporation of the collected fractions gave **2.18**: [ $\alpha$ ]<sub>D</sub><sup>20</sup> -78.9 ° (*c* 0.03, CHCl<sub>3</sub>). <sup>1</sup>H NMR δ 1.50 (s, 9 H); 2.17-2.25 (m, 1 H); 2.53-2.62 (m, 1 H); 4.00 (d, *J* = 6.21 Hz, 1 H); 4.10-4.38 (m, 4 H); 4.64 (d, *J* = 4.6, Hz, 1 H); 7.30-7.77 (m, 8 H). <sup>13</sup>C NMR δ 20.8; 28.0; 47.2; 50.3; 65.1; 67.3; 81.8; 119.9; 125.2; 127.0; 127.7; 141.4; 144.5; 155.8; 170.3. ESMS *m/z* 402.1 (M+Na)<sup>+</sup>. HRMS calcd. for C<sub>23</sub>H<sub>25</sub>NO<sub>4</sub> (M+Na)<sup>+</sup> 402.16758, found 402.16822.

**$\alpha$ -*tert*-Butyl  $\beta$ -Methyl  $\beta$ -Allylaspartate (2.19):**

Diester **2.13** (11.16 g, 25.16 mmol, 100 mol% prepared according to reference 59) was dissolved in 230 ml of dry THF, cooled in an acetone/dry ice bath to  $-78$  °C, treated dropwise with NaHMDS (26.4 ml of a 1M solution in THF, 105 mol%), stirred at  $-78$ °C for 1h, treated with allyl iodide (4.6 ml, 50.3 mmol, 200 mol%), and stirred for 2h. The cold reaction mixture was quenched with methanol (25 ml) and 1M  $\text{NaH}_2\text{PO}_4$  (60 ml), allowed to warm to room temperature, and extracted ( $3 \times 100$  ml) with ethyl acetate. The combined organic phases were washed with brine, dried over  $\text{MgSO}_4$  and concentrated to a residue that was chromatographed using 3-5% EtOAc in hexanes as eluant. Evaporation of the collected fractions gave a mixture of two diastereomers in a 3:2 ratio as assessed by measurement of the diastereomeric methyl ester singlets in the NMR spectrum (11.63 g, 95% yield).  $^1\text{H}$  NMR for the major diastereomer:  $\delta$  1.26 (s, 9 H); 2.09-2.17 (m, 1 H); 2.43-2.67 (m, 2 H); 2.87- 2.96 (m, 1 H); 3.27- 3.37 (d,  $J = 9.4$  Hz, 1 H); 3.70 (s, 3 H); 5.00-5.06 (m, 2 H); 5.66-5.75 (m, 1 H); 7.24-7.74 (m, 13 H).  $^{13}\text{C}$  NMR  $\delta$  28.0; 32.5; 50.8; 51.5; 57.1; 57.9; 72.9; 77.6; 81.5; 172.9, 173.0. ESMS  $m/z$  484.1 ( $\text{M}$ ) $^+$ . HRMS calcd. for  $\text{C}_{31}\text{H}_{33}\text{NO}_4$  ( $\text{M}+\text{H}$ ) $^+$  484.24824, found 484.24852.

**(2*S*,3*S*)- and (2*S*,3*R*)-3-Hydroxymethyl-2-[(PhF)amino]-hex-5-enoic Acid *tert*-Butyl Ester (2.20):**

To a stirred solution of alkylated diester **2.19** (11.63, 24.06 mmol, 100 mol%) in THF (484 ml) at  $-40$  °C, DIBAL-H (72.2 ml of a 1M solution in THF, 300 mol %) was added and stirring was continued for 3h. The mixture was treated with acetone (15 ml) to quench excess hydride, diluted with methanol (50 ml), allowed to warm to room

temperature and evaporated to a residue that was dissolved in ether (500 ml) and washed with NaOH 1M (3 × 150 ml). The combined organic layers were washed with brine, dried, filtered, and evaporated. The residue was first chromatographed with 5-10% EtOAc in hexanes to provide a mixture of diastereomers, that were separated by performing another column using toluene-isopropylether (8:2) as eluant.

Minor diastereomer (2*S*,3*S*)-**2.20** (3.4 g, 30% yield) eluted first:  $[\alpha]_D^{20} -327.3^\circ$  (*c* 0.01, CHCl<sub>3</sub>). <sup>1</sup>H NMR δ 1.25 (s, 9 H); 1.62-1.66 (m, 1 H); 1.96-2.05 (m, 1 H); 2.17-2.25 (m, 1 H); 2.79 (d, *J* = 3.2 Hz, 1 H); 3.55 (s, 1 H); 3.49 (dd, *J* = 11.1; 8.0 Hz; 1 H); 3.63 (dd, *J* = 11.0; 4.3 Hz, 1 H); 4.89-5.03 (m, 2 H); 5.60-5.7 (m, 1 H); 7.23-7.71 (m, 13 H). <sup>13</sup>C NMR δ 27.9; 30.4; 43.9; 57.3; 60.9; 62.9; 73.1; 81.1; 173.7.

Major diastereomer (2*S*,3*R*)-**2.20** (6.7 g, 61%) eluted second:  $[\alpha]_D^{20} -227.3^\circ$  (*c* 0.01, CHCl<sub>3</sub>). <sup>1</sup>H NMR δ 1.11 (s, 9 H); 1.58-1.66 (m, 1 H); 1.69-1.85 (m, 2 H); 2.49 (d, *J* = 6.1 Hz, 1 H); 3.41 (dd, *J* = 11.3; 7.1 Hz, 1 H); 3.63 (dd, *J* = 11.3; 2.8 Hz, 1 H); 4.68-4.79 (m, 2 H); 5.35-5.46 (m, 1 H); 7.11-7.61 (m, 13 H). <sup>13</sup>C NMR δ 28.0; 33.1; 44.2; 59.3; 64.1; 73.1; 77.4; 81.6; 174.5. ESMS *m/z* 478.0 (M+Na)<sup>+</sup>. HRMS calcd. for C<sub>30</sub>H<sub>33</sub>NO<sub>3</sub> (M+H)<sup>+</sup> 456.25332, found 456.25338.

**(2*S*,3*R*)-2-[*N*-(PhF)Amino]-3-(toluenesulfonyloxymethyl)-hex-5-enoic Acid *tert*-Butyl Ester (2.21):**

A magnetically stirred solution of (2*S*,3*R*)-alcohol **2.20** (4.41 g, 9.65 mmol, 100 mol%) and dry pyridine (9.6 ml) in dry CH<sub>2</sub>Cl<sub>2</sub> (96 ml) was cooled to 0 °C, treated with solid toluenesulfonyl chloride (5.56 g, 28.9 mmol), stirred at 0 °C for 2 h and at room

temperature for 24h, and poured into ice water. The mixture was extracted with ethyl acetate (3 × 100 ml). The combined organic phase was washed with brine, dried (MgSO<sub>4</sub>) and evaporated to a residue that was chromatographed using 5-10% EtOAc in hexanes as eluant. First to elute was (2*S*,3*S*)-3-allyl azetidine **2.1** (1.06 g, 38% yield) as a solid: m.p. 112.3-113.3 °C, spectral properties were identical to those reported below. Second to elute was (2*S*,3*R*)-tosylate **2.21** (3.18 g, 47% yield): a clear oil [ $\alpha$ ]<sub>D</sub><sup>20</sup> -282.8° (*c* 0.01, CHCl<sub>3</sub>). <sup>1</sup>H NMR  $\delta$  1.13 (s, 9 H); 1.65 (s, 1 H); 1.95 (dd, *J* = 5.5; 4.7 Hz, 2 H); 2.33 (s, 3 H); 2.52 (s, 1 H); 3.87-3.92 (m, 2 H); 4.71 (d, *J* = 12.8 Hz, 2H); 5.10-5.30 (m, 1 H); 7.05-7.67 (m, 17 H). <sup>13</sup>C NMR  $\delta$  21.7; 27.9; 31.5; 43.6; 55.2; 70.5; 73.0; 81.5; 173.3.

**(2*S*,3*S*)-2-[*N*-(PhF)Amino]-3-(toluenesulfonyloxymethyl)-hex-5-enoic Acid *tert*-Butyl Ester (2.21):**

(2*S*,3*S*)-Tosylate was synthesized from (2*S*,3*S*)-alcohol **2.20** (222 mg, 0.486 mmol, 100 mol%) using the same procedure as that described above. The residue was chromatographed with 5-10% EtOAc in hexanes as eluant. First to elute was (2*S*,3*R*)-3-allyl-1-(PhF)-azetidine-2-carboxylic acid *tert*-butyl ester **2.1** (45 mg, 21%) as white crystals: m.p. 128.5-129.5 °C, spectral properties were identical to those reported below. Second to elute was (2*S*,3*S*)-tosylate **2.21** (197 mg, 66% yield): a clear oil [ $\alpha$ ]<sub>D</sub><sup>20</sup> -146.4° (*c* 0.01, CHCl<sub>3</sub>). <sup>1</sup>H NMR  $\delta$  1.25 (s, 9 H); 1.83 (s, 1 H); 2.11-2.14 (m, 2 H); 2.51(s, 3 H); 2.63 (s, 1 H); 3.22 (s, 1 H); 4.02-4.11 (m, 2 H); 4.88 (d, *J* = 13.2 Hz, 2 H); 5.34-5.40 (m, 1 H); 7.22-7.84 (m, 17 H). <sup>13</sup>C NMR 21.6; 27.8; 31.5; 43.6; 55.1; 70.4; 73.0; 81.4; 173.2. ESMS *m/z* 610.4 (M+H)<sup>+</sup>.

**(2*S*,3*S*)-3-Allyl-1-(PhF)-azetidine-2-carboxylic Acid *tert*-Butyl Ester (2.1):**

A vigorously stirred mixture of (2*S*,3*R*)-tosylate **2.21** (698 mg, 1.14 mmol, 100 mol%) and powdered Cs<sub>2</sub>CO<sub>3</sub> (560 mg, 1.71 mmol, 150 mol%) in 10 ml of acetonitrile was heated at reflux under argon for 19 h, cooled and evaporated to a residue, which was poured into ice water (15 ml) and extracted with EtOAc (3 × 20 ml). The combined organic phases were washed with brine, dried (MgSO<sub>4</sub>) and evaporated to a foam. Chromatography using 3-5% EtOAc in hexanes as eluent provided (2*S*,3*S*)-3-allyl-1-(PhF)-azetidine-2-carboxylic acid *tert*-butyl ester **2.1** (340 mg, 68 % yield) as white crystals: m.p. 112.3-113.3 °C. [ $\alpha$ ]<sub>D</sub><sup>20</sup> 95.1° (*c* 0.01, CHCl<sub>3</sub>). <sup>1</sup>H NMR  $\delta$  1.25 (s, 9 H); 1.92-2.00 (m, 2 H); 2.54-2.62 (m, 1 H); 2.99 (t, *J* = 7.3 Hz, 1 H); 3.13 (d, *J* = 7.0 Hz, 1 H); 3.58 (t, *J* = 7.3 Hz, 1 H); 4.89 (d, *J* = 14.7 Hz, 2 H); 5.50-5.60 (m, 1 H); 7.22-7.80 (m, 13 H). <sup>13</sup>C NMR  $\delta$  27.8; 33.9; 36.9; 52.3; 66.1; 76.1; 79.8; 171.7. HRMS calcd. For C<sub>30</sub>H<sub>31</sub>NO<sub>2</sub> (M+Na)<sup>+</sup> 460.22470 found 460.22582.

**(2*S*,3*R*)-3-Allyl-1-(PhF)-azetidine-2-carboxylic Acid *tert*-Butyl Ester (2.1):**

(2*S*,3*R*)-Azetidine **2.1** was synthesized from (2*S*,3*S*)-tosylate **2.21** (214 mg, 100  $\mu$ mol) using the same procedure as that described above to provide (2*S*,3*R*)-3-allyl-1-(PhF)-azetidine-2-carboxylic acid *tert*-butyl ester **2.1** (80 mg, 52% yield) as white crystals: m.p. 128.5-129.5 °C; [ $\alpha$ ]<sub>D</sub><sup>20</sup> 127.6° (*c* 0.01, CHCl<sub>3</sub>); <sup>1</sup>H NMR  $\delta$  1.21 (s, 9 H); 2.18-2.26 (m, 1 H); 2.32-2.40 (m, 1 H); 2.47-2.55 (m, 1 H); 3.24 (dd, *J* = 7.5; 3.7 Hz, 1 H), 3.38 (d, *J* = 9.2 Hz, 1 H); 3.50 (t, *J* = 8.7 Hz, 1 H); 4.95-5.02 (m, 2 H); 5.61-5.71 (m, 1 H); 7.14-7.76 (m, 13 H). <sup>13</sup>C NMR  $\delta$  28.1; 30.6; 34.1; 51.0; 61.6; 76.0; 80.3; 170.2.

**(2*S*,3*S*)-3-Propyl-azetidine-2-carboxylic Acid *tert*-Butyl Ester Hydrochloride (2.22):**

A solution of (2*S*,3*S*)-**2.1** (110 mg, 0.25 mmol, 100 mol%) in 10 ml of EtOH : HOAc (9 :



1) was transferred into a hydrogenation apparatus and treated with palladium-on-carbon (20 mg, 10 wt %). The pressure bottle was filled, vented, and refilled four times with 6 atm of H<sub>2</sub>. The reaction mixture was stirred overnight (24 h), filtered onto a plug of Celite<sup>R</sup> 521 (Aldrich USA), and washed thoroughly with EtOH. The filtrate was treated with 5 drops of 1N HCl and the volatiles were evaporated to give a crude residue of **2.22** (50 mg) as the hydrochloride salt that was used directly for the Fmoc protection: <sup>1</sup>H NMR (CD<sub>3</sub>OD, 400 MHz) δ 0.85 (t, *J* = 7.3 Hz, 3 H); 1.14-1.29 (m, 2 H); 1.45 (s, 9 H); 1.49-1.63 (m, 2 H), 3.06-3.11 (m, 1 H), 3.48-3.58 (m, 1 H), 4.02 (dd, *J* = 19.7; 9.2 Hz, 1 H); 4.85 (d, *J* = 9.6 Hz, 1 H). <sup>13</sup>C NMR δ 13.6; 19.6; 28.0; 35.1; 37.1; 48.7; 62.9; 84.6; 166.7. ESMS *m/z* 200.0 (M+H)<sup>+</sup>.

**Typical procedure for Fmoc protection of azetidine derivatives. (2*S*,3*S*)-3-Propyl-1-(Fmoc)-azetidine-2-carboxylic Acid *tert*-Butyl Ester (2.2):**

Amine **2.22** (50 mg, 0.25 mmol, 100 mol% from above) in 1 ml of acetone/H<sub>2</sub>O (2 : 1) was treated with FmocOSu (101.69, 0.30 mmol, 120 mol%) and NaHCO<sub>3</sub> (25.2, 0.30 mmol, 120 mol %), stirred overnight, treated with an additional 120 mol% of NaHCO<sub>3</sub>, stirred overnight and evaporated to a reduced solution that was diluted with water and washed with Et<sub>2</sub>O (4 × 2 ml). The aqueous phase was acidified to pH = 3 and extracted with EtOAc (3 × 3 ml). The combined organic phases were washed with brine, dried and evaporated to a residue that was purified by chromatography using 3-7% EtOAc in hexanes as eluant. Evaporation of the collected fractions gave **2.2** (51.9 mg, 58% yield) as a foam: [α]<sub>D</sub><sup>20</sup> -58.6 ° (*c* 0.01, CHCl<sub>3</sub>). <sup>1</sup>H NMR δ 0.85 (t, *J* = 2.8 Hz, 3 H); 1.18-1.22 (m, 2 H); 1.43 (s, 9 H); 1.46-1.52 (m, 1 H); 2.81-2.87 (m, 1 H); 3.72 (bm, 1 H); 3.67-4.31

(m, 5 H); 4.62 (s, 1 H); 7.21-7.69 (m, 8 H);  $^{13}\text{C}$  NMR  $\delta$  13.9; 20.2; 28.1; 31.7; 32.9; 47.3; 53.4; 54.1; 67.3; 82.2; 120.0; 125.3; 127.1; 127.7; 141.3; 144.2; 156.0; 168.7. ESMS  $m/z$  444.1 (M+Na) $^+$ . HRMS calcd. For  $\text{C}_{26}\text{H}_{31}\text{NO}_4$  (M+H) $^+$  422.23258, found 422.23242.

**(2*S*,3*S*)-3-(3-Hydroxypropyl)-1-(PhF)-azetidine-2-carboxylic Acid *tert*-Butyl Ester (2.23):**

Borane methyl sulfide complex (25.98 mg, 0.342 mmol, 300 mol%) was added to a solution of 3-allyl-azetidine **2.1** (50 mg, 0.114 mmol, 100 mol %) in anhydrous THF (1 ml) at 0° C under argon, stirred for 3 h and treated dropwise with 3N NaOH (0.342 ml, 900 mol %) which resulted in a vigorous evolution of gas. Hydrogen peroxide (35% aqueous, 0.119 ml, 900 mol %) was added to the mixture, which was stirred for 2 h, poured into water (12 ml) and extracted with EtOAc (4 ×10 ml). The combined organic phases were dried, filtered, and concentrated *in vacuo* to a residue that was chromatographed using  $\text{CHCl}_3:\text{CH}_3\text{OH}$  97:3 as eluant to provide primary alcohol **2.23** (48.5 mg, 93% yield) as a light white solid: m.p. 214.6-215.6 °C.  $[\alpha]_D^{20}$  88.0 (*c* 0.01,  $\text{CHCl}_3:\text{MeOH}$ , 3:1).  $^1\text{H}$  NMR ( $\text{CDCl}_3:\text{CD}_3\text{OD}$ , 3:1, 400 MHz)  $\delta$  1.09-1.24 (m, 13 H); 2.32 (dd, *J* = 14.0; 7.0 Hz, 1 H); 2.90 (t, *J* = 6.9 Hz, 2 H); 3.32-3.36 (m, 2 H); 3.47 (t, *J* = 7.2 Hz, 1 H); 7.10-7.70 (m, 13 H).  $^{13}\text{C}$  NMR ( $\text{CDCl}_3:\text{CD}_3\text{OD}$ , 3:1, 400 MHz)  $\delta$  27.4; 29.0; 29.4; 34.8; 52.6; 61.4; 66.4; 76.0; 80.3; 172.7. ESMS  $m/z$  456.1 (M+H) $^+$ . HRMS calcd. For  $\text{C}_{30}\text{H}_{33}\text{NO}_3$  (M+H) $^+$  456.25332, found 456.25396.

**(2*S*,3*S*)-3-(-*tert*-Butyldimethylsilyloxypropyl)-1-(PhF)-azetidine-2-carboxylic Acid *tert*-Butyl Ester (2.24):**

A solution of alcohol **2.23** (500 mg, 1.09 mmol, 100 mol%) in 100 ml of CH<sub>2</sub>Cl<sub>2</sub> at room temperature was treated with TBDMSCl (496 mg, 3.29 mmol, 300 mol%), DMAP (4 mol %) and triethylamine (444 mg, 4.39 mmol, 400 mol %) and stirred for 24 h. The residue was dissolved in EtOAc and washed with 1M KH<sub>2</sub>PO<sub>4</sub> (50 ml). The aqueous phase was extracted with EtOAc (2 × 40 ml). The combined organic phases were dried and evaporated to a crude residue of **2.24** (600 mg) that was used directly in the next step. ESMS m/z 570.2 (M+H)<sup>+</sup>.

**(2*S*,3*S*)-3-(3-Hydroxypropyl)-azetidine-2-carboxylic Acid *tert*-Butyl Ester (2.25):**

A hydrogenation vessel containing a solution of silanyloxypropyl azetidine **2.24** (120 mg, 0.21 mmol, 100 mol% from above) in 20 ml of MeOH:AcOH (9:1) was charged with 12 mg of palladium-on-carbon (10 wt %) and stirred for 24 h under 8 atm of hydrogen. The reaction mixture was filtered through Celite™ and washed with EtOAc (30 ml) and MeOH (20ml). The filtrate was evaporated to dryness. The residue was triturated with hexane (3 × 10 ml). The remaining solid was used without additional purification. <sup>1</sup>H NMR of crude **2.25**: δ 1.44 (s, 9 H); 1.45-1.61 (m, 2 H); 1.74-1.82 (m, 2 H); 2.81 (dd, *J* = 15.3; 7.7 Hz, 1 H); 3.57 (m, 3 H); 3.87 (t, *J* = 8.8 Hz, 1 H); 4.33 (d, *J* = 7.0 Hz, 1 H). <sup>13</sup>C NMR δ 28.0; 29.5, 30.0, 30.9, 48.9, 61.8, 63.2, 83.4, 169.3; ESMS m/z 216.0 (M+H)<sup>+</sup>.

**(2*S*,3*S*)-3-(3-Hydroxypropyl)-1-Fmoc-azetidine-2-carboxylic Acid *tert*-Butyl Ester (2.26):**

(2*S*,3*S*)-1-Fmoc-3-(3-Hydroxypropyl)-Aze **2.26** (120 mg, 66% yield from **2.23**) was

synthesized from crude (2*S*,3*S*)-3-(3-hydroxypropyl)-Aze **2.25** (90 mg, 0.418 mmol) using the general Fmoc protection protocol described above:  $^1\text{H}$  NMR  $\delta$  1.44 (s, 9 H); 1.50-1.66 (m, 2 H), 1.73 (dd,  $J = 14.7; 7.4$  Hz, 2 H); 2.10 (s, 1 H); 3.54 (dd,  $J = 8.0; 4.1$  Hz, 1 H); 3.62 (t,  $J = 6.1$  Hz, 2 H); 4.05-4.35 (m, 6 H); 7.25-7.73 (m, 8 H).  $^{13}\text{C}$  NMR  $\delta$  14.2; 28.0; 28.2; 29.6; 30.3; 35.0; 47.2; 62.0; 67.3; 81.9; 119.9; 125.2; 127.1; 127.7; 141.3; 144.0; 156.1; 170.0. ESMS  $m/z$  437.9 (M) $^+$ .

**(2*S*,3*S*)-3-(3-Methanesulfonyloxypropyl)-1-Fmoc-azetidine-2-carboxylic Acid *tert*-Butyl Ester (2.27):**

A solution of alcohol **2.26** (61 mg, 0.133 mmol, 100 mol %) in 11 ml of  $\text{CH}_2\text{Cl}_2$  at 0 °C was treated with DMAP (1.63 mg, 10 mol%),  $\text{Et}_3\text{N}$  (0.055 ml, 0.399 mmol, 300 mol%) and methanesulfonyl chloride (0.041 ml, 0.532 mmol, 400 mol %). The ice bath was removed and the mixture was stirred for 5h at room temperature when TLC showed no remaining starting material ( $R_f = 0.19$ , 30% EtOAc in hexanes). The mixture was partitioned between EtOAc (45 ml) and water (15 ml). The organic layer was washed with 2N HCl (10 ml), 5%  $\text{NaHCO}_3$  (10 ml) and water, dried and evaporated to a residue that was purified by chromatography using 30-35% EtOAc in hexanes as eluant. Evaporation of the collected fractions provide an oil (57 mg, 80 % yield) of **2.27**:  $^1\text{H}$  NMR  $\delta$  1.42 (s, 9 H); 1.782-1.88 (m, 4 H); 2.48-2.52 (m, 1 H); 3.02 (dd,  $J = 8.0; 2.7$  Hz, 3 H), 3.57 (dd,  $J = 8.0; 2.7$  Hz, 1 H); 4.08-4.37 (m, 7 H); 7.28-7.76 (m, 8 H).  $^{13}\text{C}$  NMR  $\delta$  14.3; 26.5; 28.1; 28.2; 29.9; 34.6; 37.5; 47.3; 67.3; 69.0; 82.1; 120.0; 125.3; 127.1; 127.8; 141.3; 143.9; 156.1; 169.7. ESMS  $m/z$  538.1 (M+Na) $^+$ .

**(2*S*,3*S*)-3-(3-Azidopropyl)-1-Fmoc-azetidine-2-carboxylic Acid *tert*-Butyl Ester (2.3):**

Methanesulfonate **2.27** (42 mg, 0.08 mmol, 100 mol%) was dissolved in DMF (5 ml), and treated with  $\text{NaN}_3$  (26.32 mg, 0.405 mmol, 500 mol%), stirred at 80 °C for 8h, cooled and partitioned between EtOAc (12 ml) and water (6 ml). The organic layer was washed with 2N HCl (5 ml), 5 %  $\text{NaHCO}_3$  (5 ml) and water (5 ml), dried and evaporated. The residue was chromatographed using 3-5% EtOAc in hexanes as eluant. Evaporation of the collected fractions gave azide **2.3** as white foam (23 mg, 62% yield): IR  $\text{cm}^{-1}$  2098.44.  $^1\text{H}$  NMR  $\delta$  1.30 (s, 9 H); 1.46-1.64 (m, 5 H); 2.50-2.60 (m, 2 H); 2.74 (dd,  $J = 11.7$ ; 6.8 Hz, 1 H); 2.96 (dd,  $J = 11.6$ ; 7.6 Hz, 1 H), 3.22 (dd,  $J = 12.5$ ; 6.3 Hz, 2 H); 3.52 (t,  $J = 6.3$  Hz, 1 H); 3.80 (t,  $J = 7.1$  Hz, 1 H); 7.18-7.68 (m, 8 H).  $^{13}\text{C}$  NMR  $\delta$  26.5; 28.1; 31.4; 35.0; 46.1; 51.3; 58.5; 63.1; 72.8; 81.1; 119.7; 125.6; 126.8; 127.2; 141.1; 146.2, 171.9. ESMS  $m/z$  419.1 (M- 43) $^+$ .

**(2*S*,3*S*)-3-(2-Carboxyethyl)-1-Fmoc-azetidine-2-carboxylic Acid *tert*-Butyl Ester (2.4):**

A mixture of alcohol **2.26** (0.114 mmol, 100 mol%), TEMPO (1.23 mg),  $\text{CH}_3\text{CN}$  (0.57 ml) and sodium phosphate buffer (0.427 ml, 0.67 M, pH = 6.7) was heated to 35 °C, treated with sodium chlorite ( $\text{NaClO}_2$ , 6 mg, 80%, 0.228 mmol in 0.114 ml  $\text{H}_2\text{O}$ ), stirred 5 min and treated with dilute bleach (0.0014 ml, 10%  $\text{NaOCl}$  diluted into 0.057 ml). The mixture was stirred at 35 °C for 24 h when TLC showed no starting material ( $R_f = 0.30$ , 4% MeOH in  $\text{CHCl}_3$ ). The pH was adjusted to 8.0 with 2.0 N NaOH (~0.136 ml). The reaction was quenched by pouring into cold (0 °C)  $\text{Na}_2\text{SO}_3$  solution (0.57 ml, 0.5 M) maintaining the bath temperature below 20 °C. The pH of the aqueous layer was between 8.5-9.0. After stirring for 0.5 h at room temperature, diethyl ether (2 ml) was added. The

organic layer was separated and discarded. The aqueous layer was treated with EtOAc (5 ml) and acidified with 2.0 N HCl (~0.5 ml) to pH 3-4. The organic layer was separated, washed with water (2 × 5 ml) and brine (1.5 ml), and concentrated to a solid that was recrystallized from EtOAc:petroleum ether (2:10). Dicarboxylate **2.4** (47 mg, 90 % yield) was isolated as white crystals: m.p. 61.5-62.5 °C.  $[\alpha]_D^{20} -56.3^\circ$  (*c* 0.01, CHCl<sub>3</sub>). <sup>1</sup>H NMR δ 1.48 (s, 9 H); 1.97-2.04 (m, 2 H); 2.34-2.49 (m, 2 H); 2.50-2.57 (m, 1 H); 3.53 (dd, *J* = 8.0; 2.6 Hz, 1 H); 4.11-4.21 (m, 3 H); 4.39 (d, *J* = 7.0 Hz, 2 H); 7.28-7.74 (m, 8 H). <sup>13</sup>C NMR δ 28.0; 28.2; 28.7; 31.0; 34.5; 47.3; 52.6; 67.4; 82.2; 120.0; 125.2; 127.1; 127.8; 141.4; 144.0; 156.2; 169.6; 177.8. ESMS *m/z* 474.2 (M+Na)<sup>+</sup>. HRMS calcd. For C<sub>26</sub>H<sub>29</sub>NO<sub>6</sub> (M+H)<sup>+</sup> 452.20676 found 452.20700.

**2.6 Acknowledgment.** This research was supported in part by the Natural Sciences and Engineering Research Council of Canada, and the Ministère de l'Éducation du Québec. We thank Ms Sylvie Bilodeau for the performing NMR experiments on azetidine **2.1** and Mr. Dalbir Sekhon for LC-MS experiments.

**Supporting Information Available:** <sup>1</sup>H and <sup>13</sup>C NMR spectra of **2.1-2.4** and **2.15-2.23, 2.25-2.27** and NOESY spectra of **2.1**.

## 2.7 References:

- 1) Adang, A. E.P., Hermkens, P. H. H., Linders, J. T. M., Ottenheijm, H. C. J., Staveren C. J. Van *Recl. Trav. Chim. Pays-Bas* **1994**, *113*, 63.
- 2) Morgan, B. A., Gainor, J. A. *Ann. Rep. Med. Chem.* **1989**, *24*, 243.
- 3) Hanessian, S., McNaughton-Smith, G., Lombart, H. G., Lubell, W. D. *Tetrahedron* **1997**, *53*, 12789.
- 4) Giannis, A., Kotter, T. *Angew. Chem., Int. Ed. Engl.* **1993**, *32*, 1244.
- 5) Gibson, S. E., Guillo, N., Tozer, M. *Tetrahedron* **1999**, *55*, 585.
- 6) Halab, L., Gosselin, F., Lubell, W. D. *Biopolymers (peptide science)* **2000**, *55*, 101.
- 7) Holladay, M. W., Lin, C. S., May C. S., Garvey, D. S., Witte, D. G., Miller, T. R., Wolfram, C. A., Nadzan, A. M. *J. Med. Chem.* **1991**, *34*, 455.
- 8) Kolodziej, S. A., Nikiforovich, G. V., Skeeane, R., Lignon, M.-F., Martinez, J., Marshall, G. R. *J. Med. Chem.* **1995**, *38*, 137.
- 9) Plucinska, K., Kataoka, T., Yodo, M., Cody, W. L., He, J. X., Humblet, C., Lu, G. H. Lunney, E., Major, T. C., Panek, R. L., Schekun, P., Skeeane, R., Marshall, G. R. *J. Med. Chem.* **1993**, *36*, 1902.
- 10) Mosberg, H. I., Lomize, A. L., Wang, C., Kroona, H., Heyl, D. L., Sobczyk-Kojiro, K., Ma, W., Mousigian, C., Porreca, F. (1994) *J. Med. Chem.* **1994**, *37*, 4371.

- 11) Gante, J. *Angew. Chem., Int. Ed. Engl.* **1994**, *33*, 1699.
- 12) Fowden, L., Richmond, M. H. *Biochim. Biophys. Acta.* **1963**, *71*, 459.
- 13) Lane, J.M., Dehm, P., Prockop, D.J. (1971) *Biochim. Biophys. Acta* **1971**, *236*, 517.
- 14) Uitto, J., Prockop, D. J. *Biochim. Biophys. Acta*, **1974**, *336*, 234.
- 15) Zagari, A., Nemethy, G., Scheraga, H. A. *Biopolymers* **1990**, *30*, 951.
- 16) Zagari, A., Nemethy, G., Scheraga, H. A. *Biopolymers* **1990**, *30*, 967.
- 17) Zagari, A., Palmer, K. A., Gibson, K. D., Nemethy, G., Scheraga, H. A. (1994) *Biopolymers* **1994**, *34*, 51.
- 18) Deming, T. J., Fournier, M. J., Mason, T. L., Tirrell, D.A. *Macromolecules* **1996**, *29*, 1442.
- 19) Tsai, F-H., Overberger, C. G., Zand, R. *Biopolymers* **1990**, *30*, 1039.
- 20) Schlechtingen, G., Dehaven, R. N., Daubert, J. D., Cassel, J., Goodman, M. *Biopolymers* **2003**, *71*, 71.
- 21) Hanessian, S., Fu, J.-M., Chiara, J.-L., Di Fabio, R. *Tetrahedron Lett.* **1993**, *34*, 4157.
- 22) Noma, M., Noguchi, M., Tamaki, E. *Tetrahedron Lett.* **1971**, *22*, 2017.
- 23) Matsuura, F., Hamada, Y., Shioiri, T. *Tetrahedron* **1994**, *50*, 265.
- 24) Akihisa, T., Mafune, S., Ukiya, M., Kimura, Y., Yasukawa, K., Suzuki, T., Tokuda,



H., Tanabe, N., Fukuoka, T. (2004) *J. Nat. Prod.* **2004**, *67*, 479.

25) Kozikowski, A.P., Tuckmantel, W., Reynolds, I. J., Wroblewski, J. T. *J. Med. Chem.* **1990**, *33*, 1561.

26) Kozikowski, A. P., Liao, Y., Tuckmantel, W., Wang, S., Pshenichkin, S., Surin, A., Thomsen, C., Wroblewski, T. *Bioorg. Med. Chem. Lett.* **1996**, *6*, 2559.

27) Cromwell, N. H, Phillips, B. (1979) *Chem. Rev.* **1979**, *79*, 331.

28) Sariano, D. S., Pedraza, K. F., Cromwell, N. H. *J. Het.Chem.* **1980**, *17*, 623.

29) Wasserman, H. H., Lipshutz, B. H., Tremper, A.W., Wu, J. S. *J. Org. Chem.* **1981**, *46*, 2991.

30) Shioiri, T., Irako, N., Sakakibara, S., Matsuura, F., Hamada, Y. *Heterocycles* **1997**, *4*, 519.

31) Taylor, E. C., Hu, B. *Heterocycles* **1997**, *45*, 241.

32) Fushiya, S., Tamura, T., Tashiro, T., Nozoe, S. *Heterocycles* **1984**, *22*, 1039.

33) Bose, D. S., Srinivas, P., Gurjar, M. K. *Tetrahedron Lett.* **1997**, *38*, 5839.

34) Juaristi, E., Madrigal, D. *Tetrahedron* **1989**, *45*, 629.

35) Boeckman, Jr, R. K., Perni, R. B. *J. Org. Chem.* **1986**, *51*, 5489.

- 36) Starmans, W. A. J., Doppen, R. G., Thijs, L., Zwanenburg, B. *Tetrahedron: Asymmetry* **1998**, *9*, 429.
- 37) Rama Rao, A. V., Gurjar, M. K., Kaiwar, V. *Tetrahedron: Asymmetry* **1992**, *3*, 859.
- 38) Scott, L. W., Alsina, J., O'Donnell, M. J. *J. Comb. Chem.* **2003**, *5*, 684.
- 39) Seebach, D., Vettiger, T., Muller, H-M., Plattner, D. A., Petter, W. *Liebigs Ann. Chem.* **1990**, *7*, 687.
- 40) Gerona-Navarro, G., Bonache M. A., Herranz, R., Garcia-Lopez, M. T., Gonzalez-Muniz, R. *Synlett.* **2000**, *9*, 1249.
- 41) Seebach, D., Dziadulewicz, E., Behrendt, L., Cantoreggi, S., Fitzi, R. *Liebigs Ann. Chem.* **1989**, *12*, 1215.
- 42) Cativiela, C., Diaz-de Villegas, M.D. *Tetrahedron: Asymmetry* **2000**, *11*, 645.
- 43) De Kimpe, N., Boeykens, M., Tourwe, D. *Tetrahedron* **1998**, *54*, 2619.
- 44) Emmer, G. *Tetrahedron* **1992**, *48*, 7165.
- 45) Blythin, D. J., Green, M. J., Lauzon M. J. R., Shue, Ho-Jane. *J. Org. Chem.* **1994**, *59*, 6098.
- 46) Hanessian, S., Fu, J-m. (2001) *Can. J. Chem.* **2001**, *79*, 1812.
- 47) Kawahata, N, Weisberg, M., Goodman, M. *J. Org. Chem.* **2001**, *64*, 4362.

- 48) Hanessian, S., Bernstein, N., Yang, R-Y., Maguire, R. *Bioorg. Med. Chem. Lett.* **1999**, *9*, 1437.
- 49) Wessig, P., Schwarz, J. *Helv. Chim. Acta* **1998**, *81*, 1803.
- 50) Arakawa, Y., Murakami, T., Arakawa, Y., Yoshifuji, S. *Chem. Pharm. Bull.* **2003**, *51*, 96.
- 51) Hoshino, J., Hiraoka, J., Hata, Y., Sawada, S., Yamamoto, Y. *J. Chem. Soc., Perkin Trans.* **1995**, *1*, 693.
- 52) Nadir, U. K., Arora, A. *J. Chem. Soc., Perkin Trans.* **1995**, *1*, 2605.
- 53) Duréault, A., Portal, M., Carreaux, F., Depezay, J. C. *Tetrahedron* **1993**, *49*, 4201.
- 54) Jiang, J., Shah, H., DeVita, R. J. *Org. Lett.* **2003**, *5*, 4101.
- 55) Couty, F., Evano, G., Rabasso, N. *Tetrahedron: Asymmetry* **2003**, *14*, 2407.
- 56) Moore, J. A.; Ayers, R.S. "Small Ring Heterocycles part 2, Azetidines.  $\beta$ -Lactams, Diazetidines, Diaziridines"; Hassner, A., Ed.; Wiley; New York, **1983**, pp 1-217.
- 57) Wolf, J.-P., Rapoport, H. *J. Org. Chem.* **1989**, *54*, 3164.
- 58) Humphrey J. M., Bridges, R. J., Hart, J. A., Chamberlin, A.R. *J. Org. Chem.* **1994**, *59*, 2467.
- 59) Gosselin, F., Lubell, W.D. *J. Org. Chem.* **1998**, *63*, 7463.

60) Feng, Z., Lubell, W. D. *J. Org. Chem.* **2001**, *66*, 1181.

61) Brown, H. C., Kanth, J. V. B., Zaidlewicz, M. *Tetrahedron* **1999**, *55*, 5991.

62) Magnus, P., Rainey, T. *Tetrahedron* **2001**, *57*, 8647.

63) Zhao, M., Mano, J. Li. E., Song, Z., Tschaen, D. M., Grabowski, E. J. J., Rieder, P. J. *J. Org. Chem.* **1999**, *64*, 2564.

## **CHAPTER 3**

### **Synthesis of 2,4-substituted azetidin-3-ones and 4-substituted azetidine 2-carboxylic acids**

### 3.1 Introduction:

Azabicyclo[X.Y.0]alkane amino acids are constrained dipeptide mimics that can serve as conformationally fixed surrogates of peptide turn secondary structures.<sup>1,2</sup> In these bicyclic structures, three dihedral angles ( $\omega$ ,  $\psi$  and  $\phi$ ) are restricted (Figure 3.1). Incorporating these constrained scaffolds into peptides can give useful information about the bioactive conformation of the parent peptides. Enhanced activity and metabolic stability have also resulted upon incorporation of azabicyclo[X.Y.0]alkane amino acids.<sup>1,2</sup>

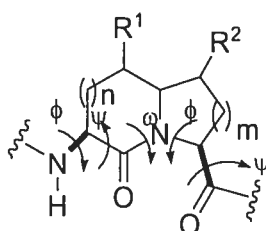
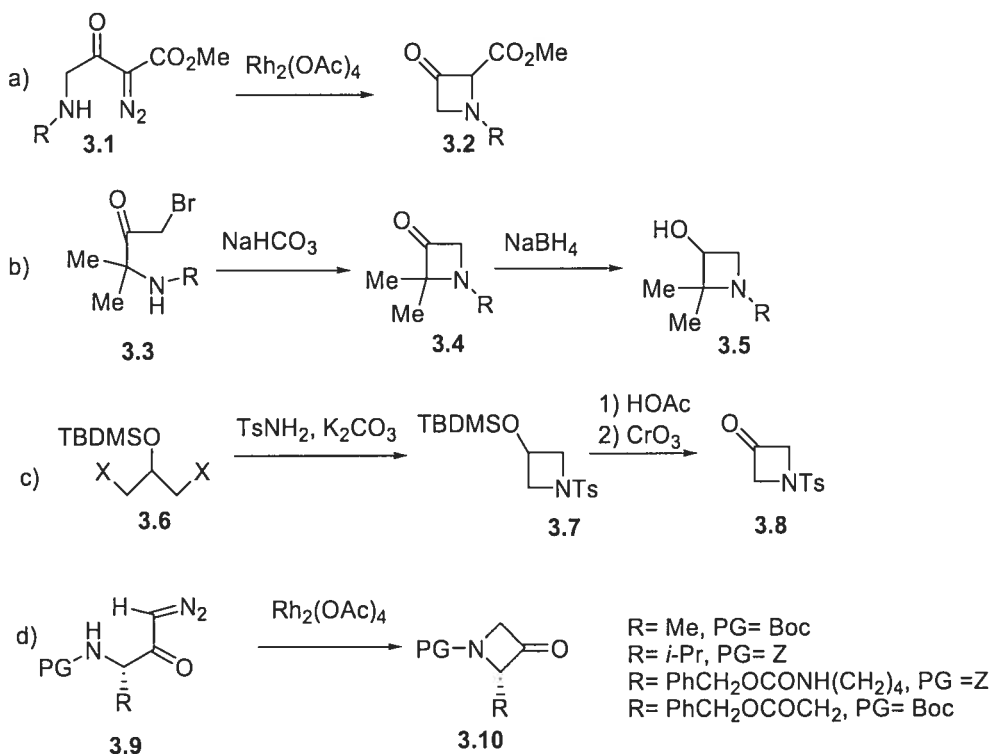

Figure 3.1: Dihedral angles constrained by an azabicyclo[X.Y.0]alkane amino acid in a peptide.

As components of  $\beta$ -lactams, fused azetidines represent one of the most important classes of antibiotics, and a large number of  $\beta$ -lactam-derivatives have been synthesized and tested for biological activity.<sup>3</sup> Due to increasing resistance of bacteria to popularly used antibiotics (*e.g.* penicillin), there is a need for new medications that show antibiotic activity. One approach is to use  $\beta$ -lactam derivatives which cannot be metabolized by the bacteria. In this respect, molecular modeling studies have proposed that the hybridization characteristics of the nitrogen in bicyclic azetidines such as fused  $\gamma$ -lactam-azetidine analogues can approximate the pyramidal distortions of the nitrogen atom observed in

penicillin.<sup>4</sup> Azetidin-3-ones are non-hydrolyzable  $\beta$ -lactam isosteres which cannot be metabolized by bacteria and they are stable to lactam cleaving enzymes.<sup>5</sup>

To the best of our knowledge only a few synthetic routes to azetidin-3-ones have been published. The intramolecular carbene-insertion reaction was studied by Rapoport and co-workers using 4-amino-2-diazo-3-oxobutanoates **3.1** (Scheme 3.1, a).<sup>6</sup> Alternatively, ring closure was also achieved using 1-amino-3-bromopropan-2-one **3.3** in an intramolecular displacement in the presence of  $\text{NaHCO}_3$  (Scheme 3.1, b).<sup>7</sup> Azetidin-3-ol **3.7** was synthesized using 1,3-dihalopropan-2-ol **3.6** and toluene-4-sulfonamide in 50–68% yield. Deprotection and oxidation of silylether **3.7** using  $\text{CrO}_3$  provided the corresponding azetidin-3-ones **3.8** (Scheme 3.1, c).<sup>8</sup> Using amino acids as starting materials, a series of 2-substituted azetidin-3-ones **3.10** have been synthesized by application of metal carbenoid insertion reactions of diazoketones **3.9** (Scheme 3.1, d).<sup>5,9</sup>



Scheme 3.1: Reported synthesis of azetidin-3-ones

acid **3.12** and azabicyclo [5.2.0] alkane amino acid **3.13** (Figure 3.3). These fused azetidines are dipeptide surrogates that offer potential for developing new antibiotics.

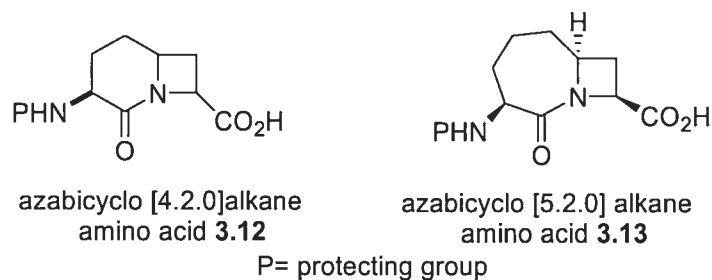

Figure 3.3: Fused azetidine targets

## 3.2 RESULTS AND DISCUSSION

### 3.2.1 Study of the synthesis of 4-substituted azetidine-3-ones by carbenoid insertion into the $\gamma$ -amino N-H bond of $\alpha$ -diazo $\beta$ -diketone and $\beta$ -ketoester substrates.

Metal carbene chemistry has been widely used as an efficient tool in organic chemistry. Although the rhodium catalyzed N-H insertion reactions of diazoketones have been frequently employed in heterocycle synthesis,<sup>11</sup> few examples of this intramolecular cyclization have been reported for forming azetidin-3-one rings.<sup>6,11-14</sup> For example, 2-carboxy-3-oxo azetidine **3.2** was prepared from glycine; however, its isolation by column chromatography using methanol in the eluent led to acid catalyzed ring opening and formation of diester **3.14** (Scheme 3.2).



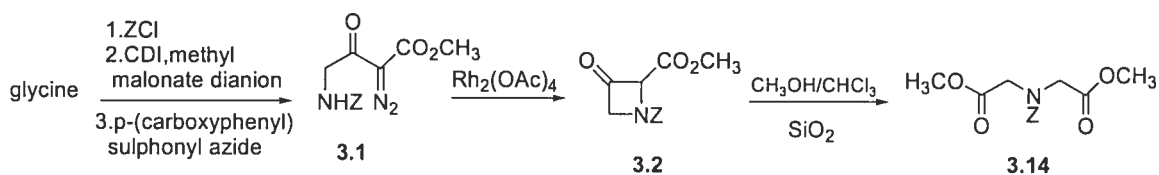

Scheme 3.2: Synthesis of 2-carboxy-3-oxoazetidines **3.2** from  $\alpha$ -diazo  $\beta$ -ketoester.<sup>6</sup>

2-Substituted azetidin-3-ones have been synthesized and used in the total synthesis of racemic *trans*-polyoximic acid from *N*-Boc glycine as starting material by application of the carbenoid insertion to N-H bond methodology.<sup>12</sup>

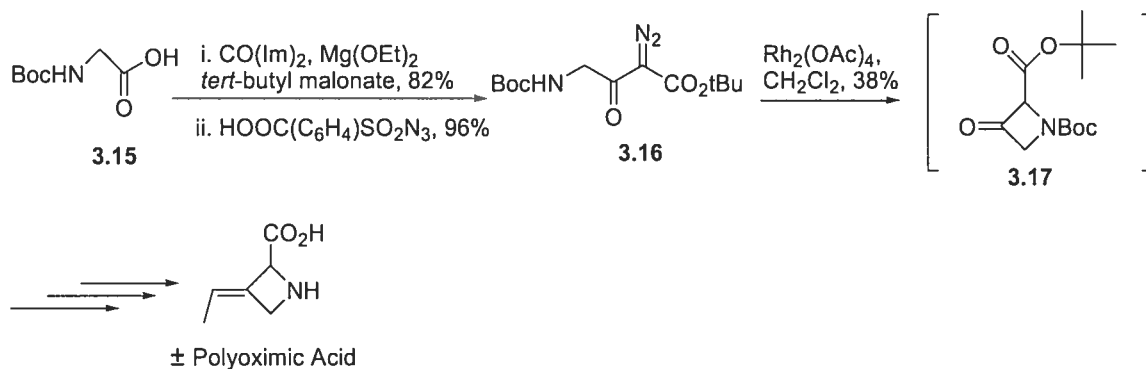

Scheme 3.3: Synthesis of racemic polyoximic acid using 2-substituted azetidinone **3.17**.<sup>12</sup>

$\alpha$ -Amino acids provided an excellent starting point for the synthesis of 2-substituted azetidine-3-ones **3.20** in enantiopure form. Application of serine in this method developed by Hanessian and co-workers led to the synthesis of polyoximic acid.<sup>9,13</sup>

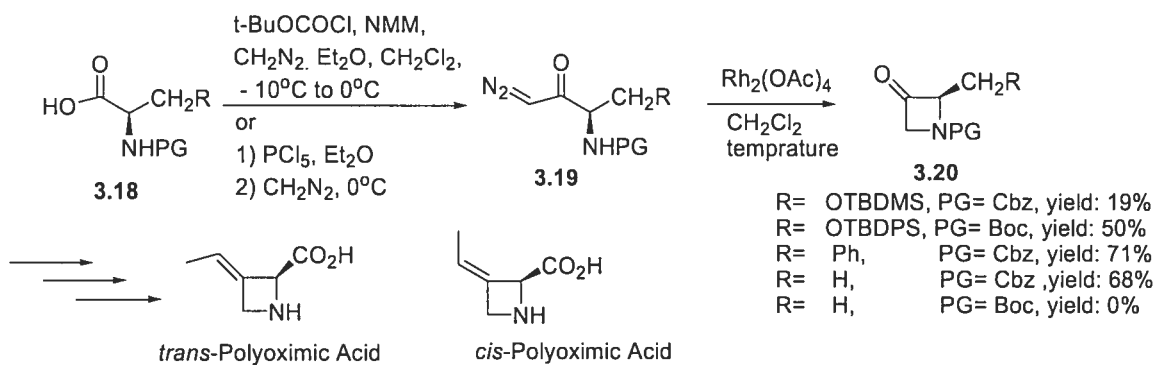

Scheme 3.4: Synthesis of enantiopure azetidin-3-one **3.20** from *N*-protected D-serine **3.18**.<sup>12,13</sup>

Similarly, 2,4-dialkyl azetidin-3-one **3.23** has been synthesized from Boc-L-serine in 35% yield. The key step was based on a rhodium carbenoid N-H insertion of  $\alpha'$ -dialkyl- $\alpha$ -diazoketone **3.22** (Scheme 3.5).<sup>14</sup>

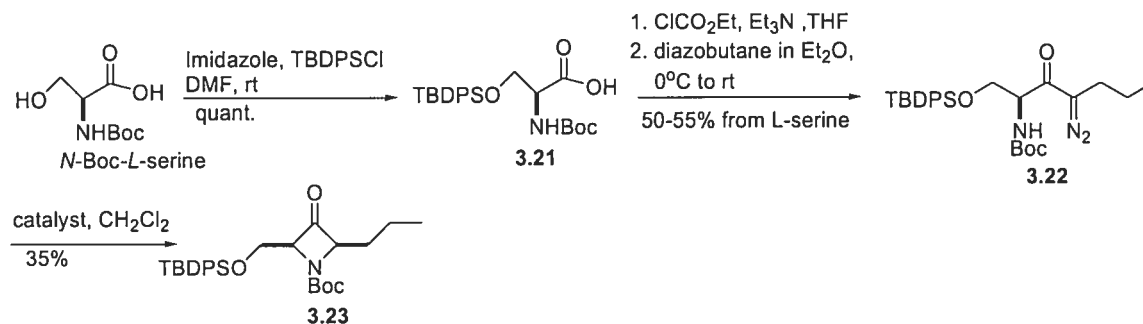

Scheme 3.5: Synthesis of 2,4-dialkyl azetidine-3-one **3.23**.<sup>14</sup>

With this precedent in hand, carbenoid insertion into the  $\gamma$ -amino N-H bond was pursued using diazo  $\beta$ -diketone and  $\alpha$ -diazo  $\beta$ -ketoester substrates.

### 3.2.1.1 Attempted synthesis of 4-substituted azetidine-3-one **3.30** via diazo insertion:

As mentioned previously, 2,4-disubstituted azetidin-3-one **3.23** was synthesized from the acylation of diazobutane with the mixed anhydride derived from protected L-serine **3.21**, followed by metal carbenoid N-H insertion (Scheme 3.3).<sup>14</sup> Inspired by this result, we conceived the synthesis of 4-substituted azetidine-3-one **3.30** from the corresponding symmetric  $\alpha$ -diazodione **3.29**.

First, *N*-Boc-L-serine *O*-*tert*-butyldiphenylsilylether **3.27** was prepared from L-serine as previously reported.<sup>11,12</sup> Acylation of L-serine with (Boc)<sub>2</sub>O and Na<sub>2</sub>CO<sub>3</sub> in 1:2 water:dioxane, followed by treatment with TBDPSCl in the presence of imidazole in DMF gave serine derivative **3.27** in 96% yield. Carboxylic acid **3.27** was activated with isobutylchloroformate and *N*-methylmorpholine (NMM) in dichloromethane and then reacted with an ethereal solution of diazomethane to provide  $\alpha$ -diazoketones **3.28**. This diazoketone was purified by column chromatography and exhibited NMR and IR spectra that were consistent with the literature.<sup>13</sup> Attempts for the synthesis of  $\alpha$ -diazodione **3.29** by acylation of  $\alpha$ -diazoketone **3.28** with the mixed anhydride derived from protected serine **3.27** using various bases (*n*-BuLi and diisopropylamine, Et<sub>3</sub>N, NMM) in different solvents (THF, CH<sub>2</sub>Cl<sub>2</sub>) at different temperatures (rt, -20, -40, -78, -90 °C) did not meet with success and led to complicated mixtures which consisted of several products (Scheme 3.6).

In an earlier attempt, *N*-Boc-L-serine *O*-*tert*-butyldimethylsilylether **3.26** was prepared; however, as noted in the literature,<sup>13</sup> the TBDMS analogs were less stable than their TBDPS counterparts. For example, activation of acid **3.26** followed by acylation of

diazomethane and chromatography over silica gel (Scheme 3.6) led to the formation of multiple unidentified materials.

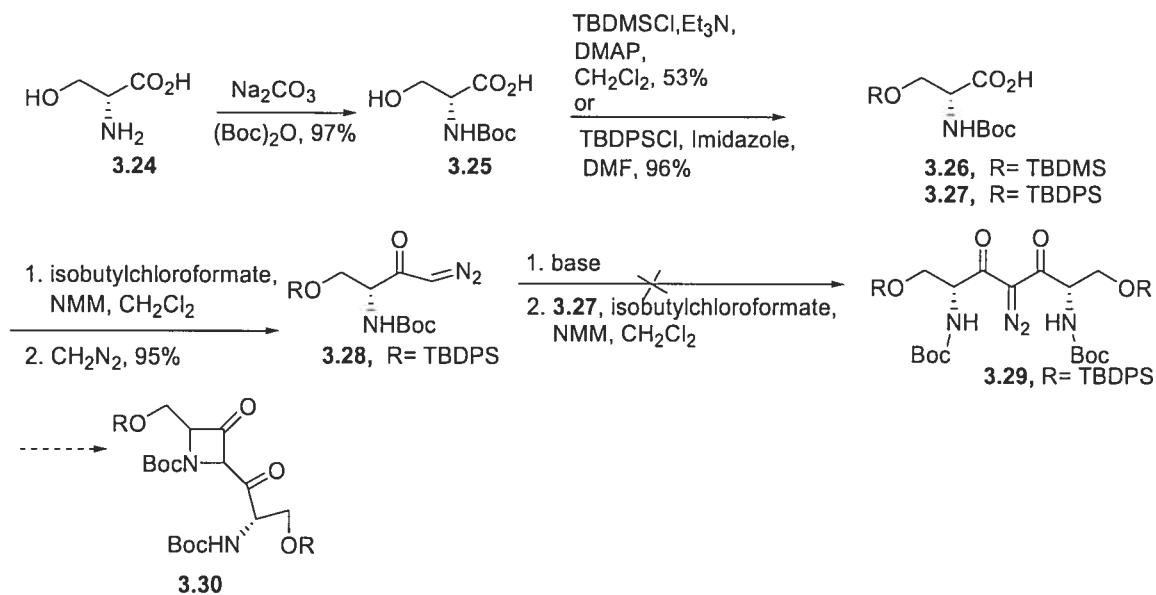

Scheme 3.6: Attempted synthesis of 4-substituted 3-azetidinone **3.30**.

### 3.2.1.2 Attempted synthesis of 4-substituted azetidine-3-one **3.34** via diazo insertion using ethyldiazoacetate:

In another effort, *N*-Boc-serine-*O*-silylether **3.27** was reacted with ethylchloroformate and a tertiary amine to afford a mixed anhydride intermediate **3.31**, which was directly reacted with ethyl diazoacetate. After purification by column chromatography, this reaction led to the formation of a side product that was studied by spectroscopic methods:  $^1\text{H}$  NMR indicated 39 protons, LC/MS analysis indicated for  $\text{C}_{28}\text{H}_{40}\text{NO}_6\text{Si}$  ( $\text{M}+\text{H}$ ) $^+$   $m/e$ :514.1, and in the IR spectrum, no signal in the desired region for  $\text{N}=\text{N}$  functional group was observed. Based on this evidence, the desired compound **3.32** was presumed to have lost  $\text{N}_2$  during purification by column chromatography, and  $\beta$ -keto ester **3.33** was formed (Scheme 3.7).

In another attempt, the residue was directly used without purification (crude **3.32**) for the cyclizations step using  $\text{Rh}_2(\text{OAc})_4$  in  $\text{CH}_2\text{Cl}_2$  but according to TLC and LC/MS analyses, several unidentified compounds were produced (Scheme 3.7).

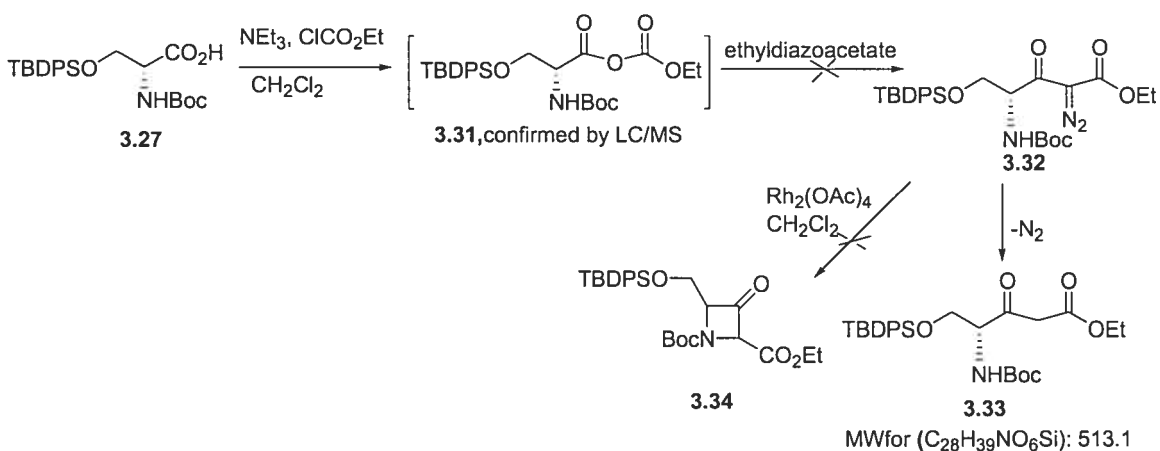

Scheme 3.7: Attempted synthesis of *N*-Boc 2,4-disubstituted azetidinone **3.34**.

In the light of the problems associated with the synthesis of  $\alpha$ -diazo compounds **3.29** and **3.32** and their subsequent ring annulations, we began to study of an alternative approach to provide  $\alpha$ -diazo keto compounds such as **3.40** for the synthesis of desired 3-azetidinone.

### 3.2.1.3 Synthesis of 4-substituted azetidine-3-one **3.43** by metal carbenoid N-H insertion on $\gamma$ -amino $\beta$ -ketophosphonate **3.39**:

Intramolecular N-H insertion reactions have yielded 5-substituted pyrrolidine 2-phosphonate **3.37** from  $\alpha$ -diazo  $\beta$ -keto phosphonate **3.36** (Scheme 3.8).<sup>15</sup>

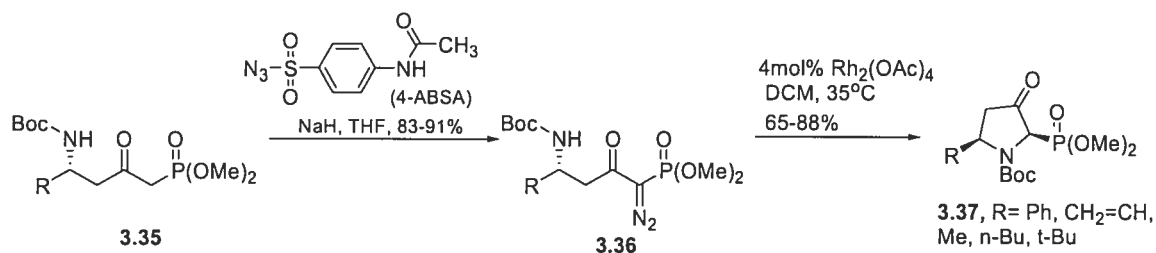

Scheme 3.8: Synthesis of 3-oxo pyrrolidine phosphonate **3.37** from  $\delta$ -amino  $\alpha$ -diazo  $\beta$ -ketophosphonate **3.36**.

Inspired by this example for making 2,5-disubstituted pyrrolidines, we investigated a complimentary route to make 2,4-disubstituted azetidines.  $\beta$ -Keto  $\alpha$ -diazo phosphonate **3.40** was derived from protected L-serine **3.38**. Esterification of *N*-(Boc)-serine-*O*-*tert*-butyldiphenyl silyl ether **3.27** with methyl iodide and sodium bicarbonate in DMF gave L-serine methyl ester **3.38** in 91% yield after chromatography.  $\beta$ -Ketophosphonate **3.39** was synthesized from methyl ester **3.38** by acylation of the lithium anion of dimethyl methyl phosphonate, produced with *n*-BuLi in THF. The diazo transfer to  $\beta$ -ketophosphonate **3.39** was accomplished using 4-acetamido benzene sulfonyl azide (4-ABSA) and sodium hydride as a base in THF to furnish  $\alpha$ -diazo  $\beta$ -ketophosphonate **3.40** in 72% yield. Diazo derivative **3.40** was heated at reflux with Rh<sub>2</sub>(OAc)<sub>4</sub> in CH<sub>2</sub>Cl<sub>2</sub> to provide *N*-Boc azetidine-2-dimethoxy phosphonate **3.41**. Attempts to purify **3.41** by column chromatography were unsuccessful and the product decomposed; however, azetidine 2-phosphonate **3.41** could be directly condensed with aldehyde **3.42** in a Wittig reaction using DBU in THF to provide azetidine **3.43** in 31% yield from **3.22** (Scheme 3.9) as a mixture of two *cis* / *trans* olefin isomers (according LC/MS) in a 3:1 ratio as assessed by measurement of the triplet signals at  $\delta$  4.78 and 4.73 ppm in the <sup>1</sup>H NMR spectrum. The structure of 2,4-disubstituted **3.43** has been characterized by <sup>13</sup>C NMR, <sup>1</sup>H

NMR and HRMS analyses. The  $^{13}\text{C}$  NMR spectrum showed three carbonyl groups, with a signal for ketone at  $\delta$  190.5 ppm, along with the carbonyl of Boc group at  $\delta$  152.3 ppm and carbonyl of the *t*-butylester at  $\delta$  174.6 ppm. The formation of a double bond was confirmed by  $^1\text{H}$  NMR which showed the presence of the vinyl proton at  $\delta$  5.58 ppm for the major olefin isomer. Further structural confirmation of **3.43** was accomplished by HRMS calculated for  $\text{C}_{52}\text{H}_{59}\text{N}_2\text{O}_6\text{Si}$  ( $\text{M}+\text{H}$ ) $^+$  835.41369, indicated the mass of 835.41484.

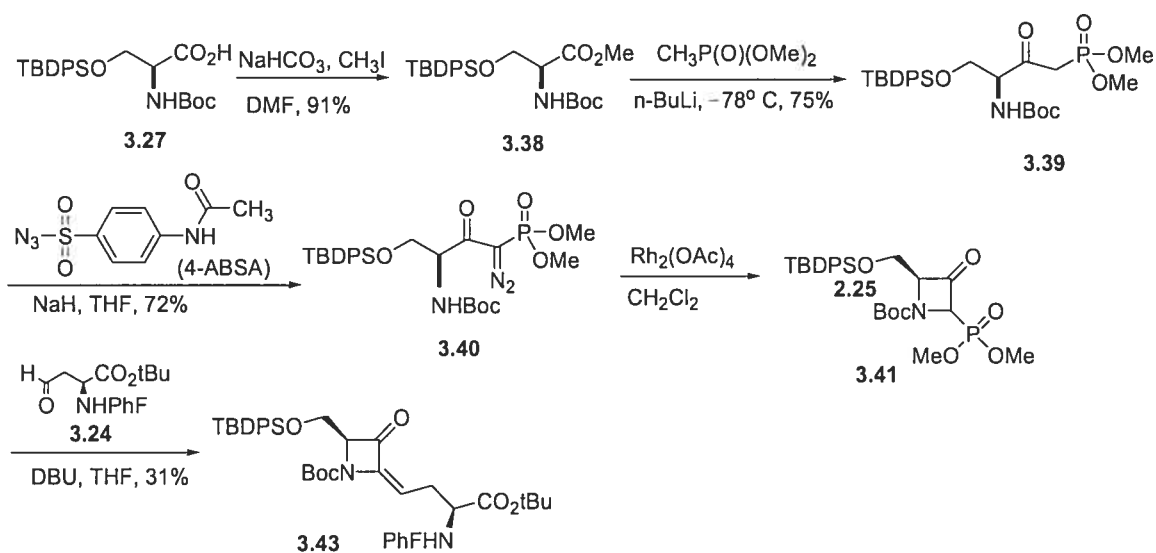

Scheme 3.9: Synthesis of 2,4-substituted azetidinone **3.43** via  $\beta$ -ketophosphonate **3.39**.

Elaboration of **3.43** toward the bicyclic azetidine analogue **3.12** via reduction of the carbonyl group of azetidinone **3.43** to the corresponding alcohol using Luche conditions or  $\text{NaBH}_4$  or  $\text{NaCNBH}_3/\text{HOAc}$ , as well as the reduction of the double bond using Pd/C in MeOH gave only recovered starting material.

In conclusion, 2,4-disubstituted azetidin-3-one **3.43** was synthesized for the first time in 7 steps from L-serine via intramolecular metal carbenoid N-H insertion of  $\alpha$ -diazo  $\beta$ -

ketophosphonate **3.40**. This method for the synthesis of substituted azetidin-3-ones may be useful for the preparation of other azetidine heterocycles.

### **3.2.2 Synthesis of 4-substituted Aze analogues by intramolecular $S_N2'$ reaction:**

Although intramolecular rhodium catalyzed insertion of diazo ketones into N-H bonds did provide 4-substituted azetidine **3.43**, the development of more efficient methodology for making these challenging heterocycles was pursued and an alternative strategy was explored.

#### **3.2.2.1 Synthesis of 4-propenyl Aze **3.48** from allylic alcohol **3.46** by $S_N2'$ displacement:**

To our knowledge, there was no precedent in the literature of using intramolecular cyclization via  $S_N2'$  reaction to form an azetidine ring, hence, a methodological study was carried out at first on simpler models to explore the appropriate conditions.

Allylic tosylate **3.47** was prepared as a model for exploring the  $S_N2'$  reaction. Treatment of ethyl acetate with the lithium anion of dimethylmethylphosphonate in THF, afforded  $\alpha$ -keto phosphonate **3.44** after distillation (bp 76-79 °C/3 mmHg) in 82% yield. Aspartate  $\beta$ -aldehyde **3.42** was treated with **3.44** in the presence of  $CS_2CO_3$  in  $CH_3CN$  to provide  $\beta,\gamma$ -unsaturated ketone **3.45** in 67% yield. Reduction of ketone **3.45** with  $CeCl_3 \cdot 7H_2O$  and  $NaBH_4$  in MeOH produced allylic alcohol **3.46** as a mixture of two diastereomers in a 4:1 ratio (confirmed by LC/MS) after purification by column chromatography. Activation of alcohol **3.46** to the corresponding tosylate **3.47** was performed using



toluenesulfonylchloride and pyridine in  $\text{CH}_2\text{Cl}_2$ . The products were purified by column chromatography using a gradient eluent of 3-10% EtOAc in hexanes and gave three fractions. The first fraction was an inseparable mixture of diastereomers and olefin isomers of azetidine **3.48** in 11% yield, and the second fraction was tosylate **3.47** in 35% yield as an inseparable mixture of diastereomers and olefin isomers. Also, alcohol **3.46** was recovered as third fraction in 28% yield after chromatography (Scheme 3.10). Attempts to prepare azetidine **3.48** from tosylate **3.47** using different bases ( $\text{Cs}_2\text{CO}_3$ ,  $\text{K}_2\text{CO}_3$ ,  $\text{Et}_3\text{N}$ ) in different solvents ( $\text{CH}_3\text{CN}$ , DMF, THF) were unsuccessful and starting material was recovered.

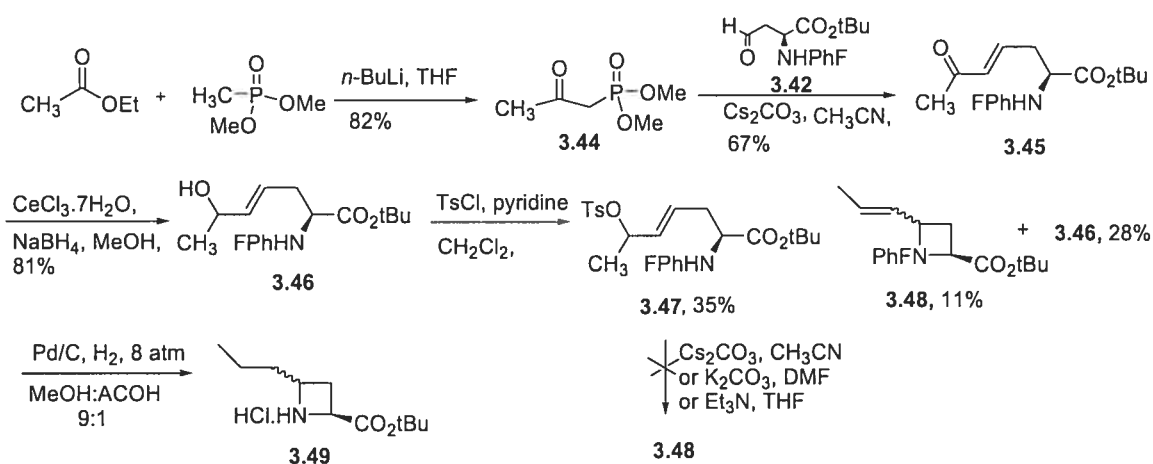

Scheme 3.10: Synthesis of 4-propenyl Aze **3.48** from allylic alcohol **3.46**.

$^1\text{H}$  NMR of azetidine **3.48**, showed a complicated spectrum that contained the mixture of two diastereomers as well as *Z* and *E* olefin isomers, which caused difficulties during spectral assignment.

For further evidence of the formation of propenyl azetidine **3.48**, hydrogenation was performed at 8 atm using palladium-on-carbon as catalyst in 9:1 MeOH:AcOH. This caused double bond reduction and cleavage of the phenylfluorenyl group. 4-Propyl

azetidine **3.49** was purified by HPLC which provided a mixture of two inseparable diastereomers of 4-propyl Aze **3.49** in a 3:2 ratio as assessed by the measurement of the diastereomeric multiplet signals at  $\delta$  3.51 and 3.33 ppm in the  $^1\text{H}$  NMR spectrum. The exact mass of 4-propyl Aze **3.49** was confirmed by HRMS. (calcd. 200.16451 for  $\text{C}_{11}\text{H}_{22}\text{NO}_2(\text{M}+\text{H})^+$ , found 200.16358).

### 3.2.2.2 Attempted synthesis of 4-substituted Aze **3.53** from allylic alcohol **3.51** by $\text{S}_{\text{N}}2'$ reaction:

To further probe the intramolecular  $\text{S}_{\text{N}}2'$  methodology, allylic alcohol **3.51** was prepared from  $\beta$ -keto phosphonate **3.39**. For the synthesis of 4-substituted Aze **3.53**, activation of alcohol **3.51** followed by cyclizations via  $\text{S}_{\text{N}}2'$  reaction was examined. The Wittig reaction of aldehyde **3.42** with serine-derived  $\beta$ -keto phosphonate **3.39** using  $\text{Cs}_2\text{CO}_3$  in  $\text{CH}_3\text{CN}$  gave  $\alpha,\beta$ -unsaturated ketone **3.50** (72% yield). Reduction of **3.50** using  $\text{CeCl}_3 \cdot 7\text{H}_2\text{O}$  and  $\text{NaBH}_4$  in MeOH gave secondary alcohol **3.51** as a mixture of diastereomers (78% yield), which were separated by column chromatography. The structure of secondary alcohol **3.51** was established by  $^1\text{H}$  NMR and  $^{13}\text{C}$  NMR. The formation of the *E*-isomer was confirmed by proton NMR which showed a vicinal coupling constant of 15.7 Hz for the vinyl protons. Attempts to activate alcohol **3.51** as the corresponding tosylate and mesylate, using toluenesulfonyl chloride and pyridine as base in  $\text{CH}_2\text{Cl}_2$  or methanesulfonyl chloride and  $\text{Et}_3\text{N}$  as base in  $\text{CH}_2\text{Cl}_2$  respectively, were however unsuccessful and only starting material was recovered (Scheme 3.11).

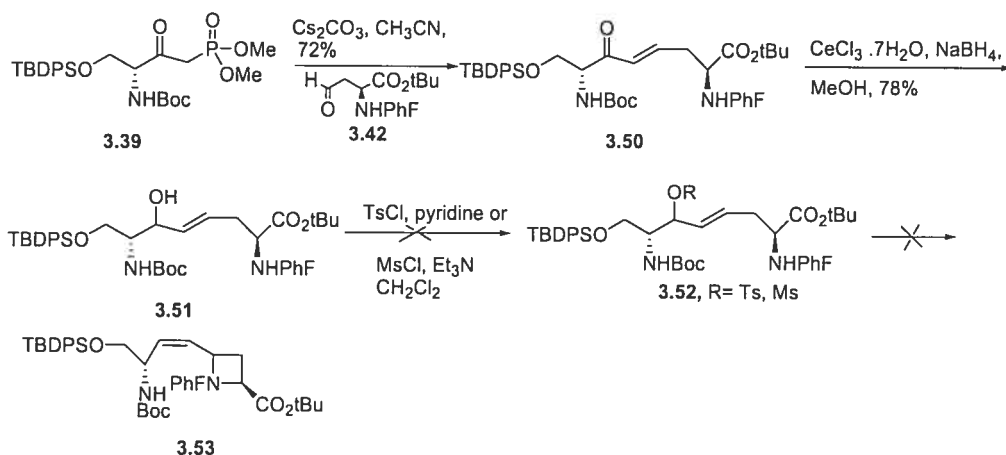

Scheme 3.11: Attempted synthesis of 4-substituted Aze **3.53** starting from serine phosphonate **3.39**.

### 3.2.2.3 Attempted synthesis of 4-vinyl Aze **3.59** from allylic alcohol **3.55**:

Preparation of 4-substituted Aze **3.59** was examined by the synthesis of allylic mesylate **3.57**. Dehydro amino adipate **3.54** was made as previously described in reference 16. Reduction of the  $\omega$ -ester of diester **3.54** using DIBAL-H in THF at  $-40^\circ\text{C}$  provided the corresponding alcohol **3.55** in 95% yield, after purification by chromatography. Attempts at activation of alcohol **3.55** to the corresponding tosylate using toluene chloride and pyridine in  $\text{CH}_2\text{Cl}_2$  were, however, unsuccessful and starting material was recovered (Scheme 3.12).

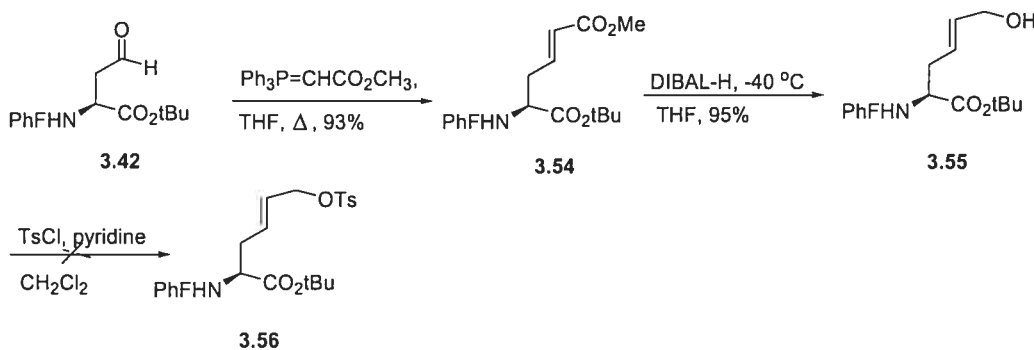

Scheme 3.12: Attempted synthesis of the tosylate derivative of alcohol **3.55**.

Alcohol **3.55** was thus converted to the corresponding mesylate **3.57** by using methanesulfonyl chloride with Et<sub>3</sub>N as base and DMAP as catalyst in dichloromethane (DCM). Under these conditions, mesylate **3.57** and pipercolate **3.58** were obtained in 43% and 38% respective yields after separation by column chromatography. The next issue was the synthesis of azetidine **3.59**. Attempts to prepare azetidine **3.59** from mesylate **3.57** using Cs<sub>2</sub>CO<sub>3</sub> in acetonitrile were unsuccessful and starting material was recovered. Employing triethylamine and HMPA at reflux led to the formation of several unidentified compounds (Scheme 3.13).

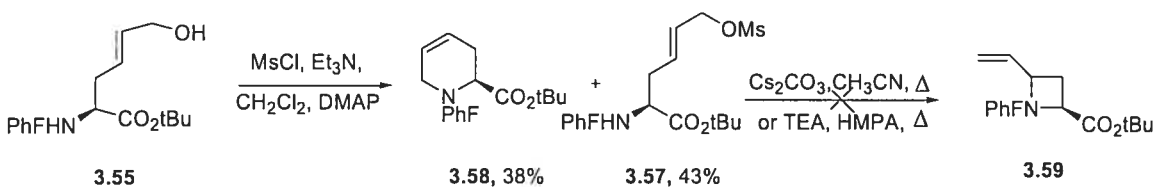

Scheme 3.13: Synthesis of pipercolate **3.58** from allyl alcohol **3.55** on route to mesylate **3.57**.

The structure of pipercolate **3.58** was assigned using NMR spectroscopy. In particular, the <sup>13</sup>C-DEPT spectrum of **3.58** in chloroform indicated the presence of two methylene groups at  $\delta$  38.76 and 45.45 ppm, and there was no methylene carbon in the vinyl region which was consistent with the formation of pipercolate **3.58** instead of azetidine **3.59**. Azetidine **3.59** was not detected in these experiments. A mechanism for the formation of pipercolate **3.58** may involve S<sub>N</sub>2' like nucleophilic attack of the DMAP to the vinylic carbon followed by displacement of the mesylate group. The intramolecular *N*-alkylation of the corresponding intermediate via an alternative S<sub>N</sub>2' of gave pipercolate **3.85** (Scheme 3.14).

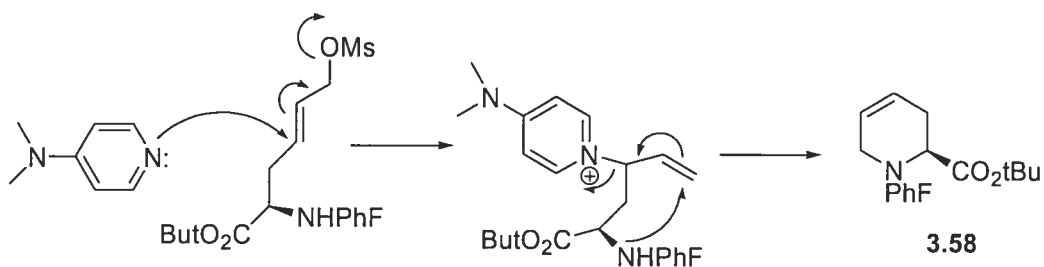

Scheme 3.14: Possible mechanism for the intramolecular  $N$ -alkylation leading to pipercolate **3.58**.

#### 3.2.2.4 Synthesis of 4-vinyl Aze **3.65** via $S_N2'$ reaction of allylic chloride **3.64**:

The  $S_N2'$  intramolecular  $N$ -alkylation to synthesize piperidines, pyrrolidines and 1,3-disubstituted 1,2,3,4-tetrahydroquinolines, has been performed with various reagents and catalysts, including complexes of  $Pd(0)$ <sup>17</sup> and  $Pd(II)$ ,<sup>18</sup> and  $Ag(I)$  salts.<sup>19</sup> For example, a 4:1 mixture of *cis*- and *trans*-2-carboxy-5-vinylpyrrolidines was synthesized in 77% yield using  $Ag(I)$  to carry out the intramolecular  $S_N2'$   $N$ -alkylation<sup>10</sup> of 2-*tert*-butoxycarbonyloxy-7-chlorohept-5-enoic acid methyl ester **3.61** (Scheme 3.15).

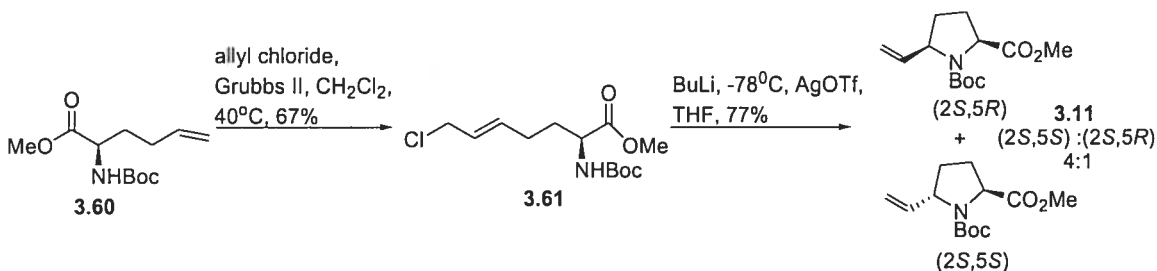

Scheme 3.15: Synthesis of 2-carboxy-5-vinylpyrrolidine **3.11** using  $AgOTf$  in  $S_N2'$  alkylation.<sup>10</sup>

The extension of this methodology was thus pursued for the synthesis of 4-vinyl Aze.  $N$ -(Boc)allylglycine **3.62** was prepared according to the literature protocol,<sup>20,19</sup> and

esterified with  $\text{CH}_3\text{I}$  and sodium bicarbonate in DMF to afford methyl allylglycinate **3.63** as a clear oil in 87% yield (Scheme 3.16).

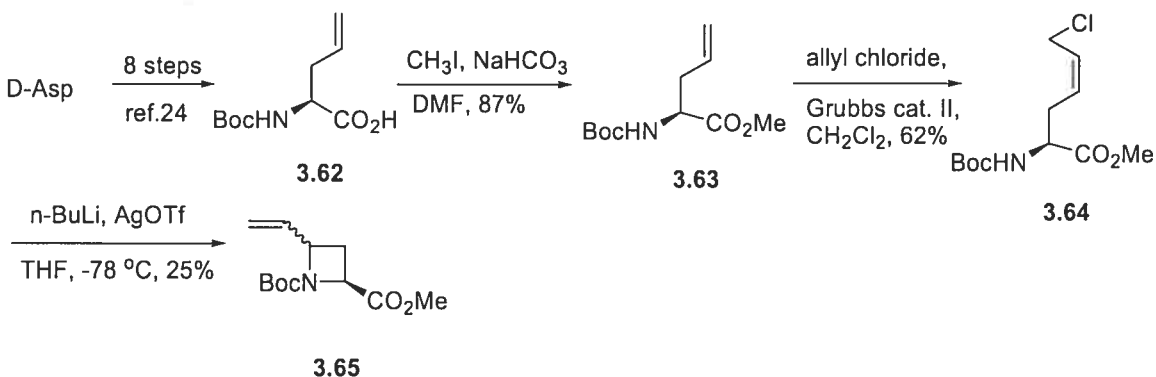

Scheme 3.16: Synthesis of vinyl azetidine **3.65**.

For the synthesis of azetidine **3.65**, our next objective was the introduction of the appropriate leaving group and subsequent intramolecular *N*-alkylation. Reaction of olefin **3.63** with a solution of allyl chloride and Grubbs second generation catalyst in  $\text{CH}_2\text{Cl}_2$  gave allyl chloride **3.64** in 62% yields. Formation of the vinyl azetidine **3.65** occurred in low yield (25%) on reaction of allyl chloride **3.64** with silver triflate and *n*-BuLi in THF (Scheme 3.16).  $^1\text{H}$  NMR of vinyl azetidine **3.65** showed the presence of two diastereomers and two amide rotamers in the vinylic region that caused difficulties during spectral assignment.  $^1\text{H}$  NMR temperature studies of vinyl azetidine **3.65** in  $\text{CHCl}_3$  at 25  $^\circ\text{C}$  in the vinylic region exhibited two *trans* and two *cis* protons in a 5.7:1 ratio as assessed by measurement of the *cis* doublet signals at  $\delta$  5.38 and 5.18 ppm. Also,  $^1\text{H}$  NMR examination of **3.65** in  $\text{CHCl}_3$  at -55  $^\circ\text{C}$  resulted in an increase of this ratio to 2.9:1 due to restricted rotation about the Boc group (Figure 3.4). Moreover, it was noted that the singlet *tert*-butyl group was particularly broad ( $\delta$  1.45-1.50 ppm at 25  $^\circ\text{C}$  and 1.39-

1.52 ppm at  $-55\text{ }^{\circ}\text{C}$ ) which suggested the presence of mixtures of diastereomers and carbamate *cis*- and *trans*-rotamers. The formation of vinyl azetidine **3.65** was confirmed by  $^{13}\text{C}$  NMR and HRMS, in which a  $^{13}\text{C}$  NMR study showed the presence of vinylic methylene groups between  $\delta$  113.2-117.3 ppm and HRMS indicated the mass of 242.10159 for  $\text{C}_{12}\text{H}_{20}\text{NO}_4$  ( $\text{M}+\text{H}$ ) $^{+}$ .

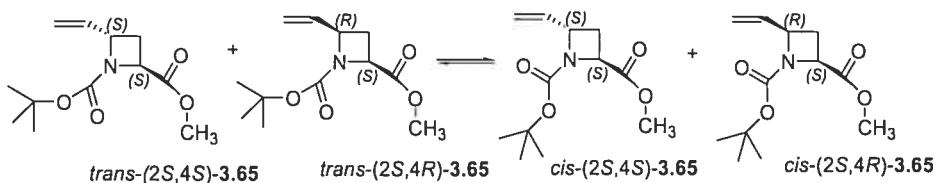

Figure 3.4: Suggested diastereomers and the carbamate *cis* and *trans*-isomers of *N*-Boc 4-vinyl azetidine 2-methyl ester **3.65**.

To further characterize azetidine **3.65**, attempts were made to remove the Boc group; however, decomposition of the azetidine ring was observed by both TLC and LC/MS analysis, when employing protic acids such as TFA in  $\text{CH}_2\text{Cl}_2$ , 4M HCl in dioxane, and HCl (g) in  $\text{CH}_2\text{Cl}_2$ . When a Lewis acid was employed, only starting material was recovered on treatment of azetidine **3.65** with  $\text{ZnBr}_2$  in  $\text{CH}_2\text{Cl}_2$  to remove the Boc group.<sup>22</sup> Furthermore, attempts to elaborate 4-vinyl azetidine **3.65** by transformations of the olefin such as conversion to the corresponding primary alcohol using hydroboration-oxidation, or saturation by hydrogenation using Pd/C in MeOH:HOAc at 4 atm, as well as the transfer the methyl ester to the corresponding ethyl ester using a solution of sodium ethoxide 0.04 M in ethanol, all failed.

In summary, a mixture of two diastereomers of 4-vinyl Aze **3.65** was synthesized in 11 steps from aspartic acid by application of allylglycine methyl ester **3.63** in a cross-metathesis / intramolecular  $\text{S}_{\text{N}}2'$  *N*-alkylation strategy.

### 3.2.3 Attempts to synthesis of 4-substituted Aze 3.71 via intramolecular nucleophilic ring opening of epoxide 3.70:

Little is known about the formation of azetidine rings by the nucleophilic ring opening of epoxides with amine nucleophiles. Although, several (*R,S*)-1-alkyl-3-hydroxy-2-phenylazetidines **3.67** were synthesized by reaction of (*R,R*)-2-(1-bromobenzyl) oxirane **3.66** with aliphatic primary amines (Scheme 3.17 a).<sup>23</sup> 3-Hydroxy azetidine **3.69** has also been made by an *exo-tet* type cyclization and double inversion in two sequential S<sub>N</sub>2 reactions on epoxyamine **3.68** (Scheme 3.17 b).<sup>24</sup>

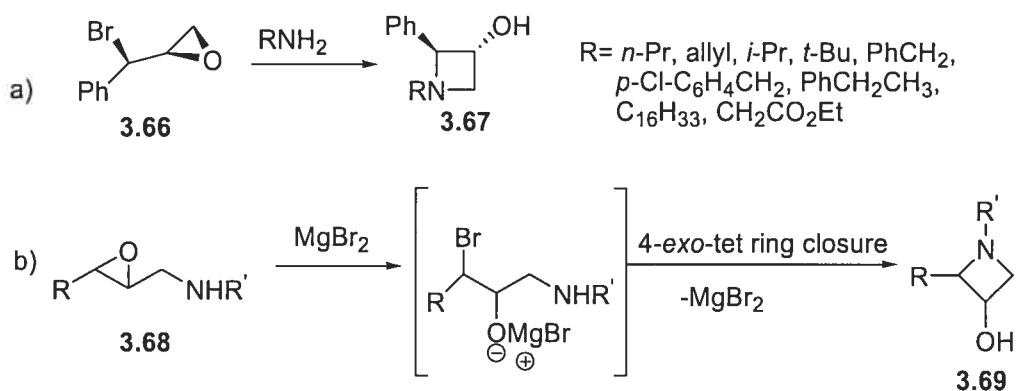

Scheme 3.17: Synthesis of azetidine ring from epoxide.

High ring strain makes epoxides reactive to nucleophilic attack.<sup>25,26</sup> We envisioned that a method based on intramolecular ring opening of the epoxide by an amine or amide could be used to prepare 4-substituted Aze. The synthesis of epoxide **3.70** and **3.74** from L-aspartic acid was thus explored in another attempt at azetidine ring formation.



### 3.2.3.1 Synthesis of epoxide 3.70 from L-aspartic acid:

Methyl allylglycinate **3.63** was synthesized as described in section 2.2.3 and reacted with meta-chloroperbenzoic acid (*m*CPBA) in CH<sub>2</sub>Cl<sub>2</sub> to give epoxides **3.70** as a 4:1 mixture of two diastereomers (according to LC/MS) in 72% yield after purification by column chromatography.

With epoxides **3.70** in hand, we tried different conditions for intramolecular nucleophilic attack using Lewis acids, such as AgOTf, CuI, Cu(OTf)<sub>2</sub>, and TiCl<sub>4</sub>, without base or by employing various bases (*n*-BuLi in THF, NaHMDS or LiHMDS in THF); formation of azetidine **3.71** was never observed, and in all cases starting material was recovered according to TLC and LC/MS analysis (Scheme 3.18).

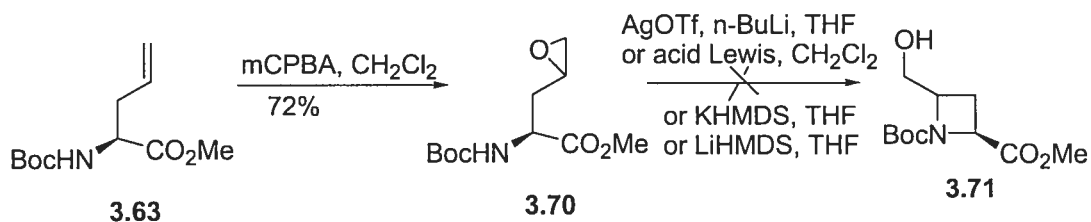

Scheme 3.18: Attempts to synthesize 4-substituted Aze **3.71** from epoxide **3.70**.

### 3.2.3.2 Synthesis of epoxide 3.74 from L-aspartic acid

The poor reactivity of the Boc protected nitrogen may be due to resonance with the carbonyl of the carbamate reducing the nucleophilicity of the nitrogen. Replacement of the Boc protecting group with a toluenesulfonamide was examined in order to increase the nucleophilicity of the nitrogen and favor *N*-alkylation. Deprotection of *N*-Boc allylglycine methyl ester **3.63** using 50:50 TFA/CH<sub>2</sub>Cl<sub>2</sub> for 20 min provided allylglycine methyl ester **3.72** in 85% yield. Protection of the nitrogen using *p*-toluene sulfonylchloride and pyridine as base in CH<sub>2</sub>Cl<sub>2</sub> gave *N*-toluenesulfonyl allylglycine **3.73**



the deprotonation of C- $\alpha$  in the epoxide **3.74** by LiHMDS or KHMDS followed by cleavage of the N-S bond.

### 3.3 Conclusion

In the context of our research on general methods for making 4-substituted Aze analogues, three different methodologies were pursued.

We have developed a new process for synthesizing 2,4-disubstituted azetidin-3-one **3.43** by employing intramolecular metal carbenoid N-H insertion of  $\alpha$ -diazo  $\beta$ -ketophosphonate **3.40** in 7 steps from L-serine. This method for the synthesis of substituted azetidin-3-ones may be useful for the preparation of other azetidine heterocycles.

In an investigation of the synthesis of 4-substituted Aze analogues via  $S_N2'$  approach, a mixture of 4-propenyl *N*-(PhF)Aze **3.48** was synthesized by the Horner-Wadsworth-Emmons (HWE) olefination of  $\alpha$ -*tert*-butyl-*N*-(PhF)aspartate  $\beta$ -aldehyde **3.42** with  $\beta$ -keto phosphonate **3.44**. Reduction of the resulting  $\alpha,\beta$ -unsaturated ketone **3.45** followed by activation of the corresponding alcohol **3.46** as the tosylate derivative **3.47** gave a diastereomeric mixture of propenyl Aze **3.48** in low yield.

In an attempt to synthesize of 4-vinyl *N*-(PhF) Aze **3.59** via  $S_N2'$  strategy starting from dehydro amino adipate **3.54**, the novel pipercolate **3.58** was formed instead of the 4-substituted azetidine **3.59**. One possible mechanism involves a  $S_N2'$  like nucleophilic attack of the DMAP to the vinylic carbon of mesylate derivative **3.57** followed by mesylate group displacement. Subsequent intramolecular *N*-alkylation of corresponding intermediate via an alternative  $S_N2'$  reaction gave pipercolate **3.58**.

Also, a mixture of 4-vinyl Aze analogue **3.65** was synthesized from L-Asp in 11 steps in low yield using Ag(I) to effect the intramolecular  $S_N2'$  *N*-alkylation. 4-vinyl Aze analogue **3.65** can serve as a precursor for the preparation of fused azabicyclo[5.2.0]alkane amino acid **3.13**, a novel  $\beta$ -turn mimic.

Although an investigation failed to produce 4-substituted Aze by intramolecular ring opening of an epoxide by nucleophilic attack of a  $\beta$ -amine, new amino epoxides **3.70**, **3.74** were synthesized for the first time from L-Asp as an inexpensive chiral educt. These amino epoxides may serve as intermediates for a variety of highly functionalized compounds.

## 3.4 Experimental procedure

### 3.4.1 General Information

Unless otherwise noted, all reactions were run under nitrogen atmosphere and distilled solvents were transferred by syringe. Anhydrous tetrahydrofuran (THF), dichloromethane (DCM), acetonitrile (CH<sub>3</sub>CN) and dimethylformamide (DMF) were obtained from solvent filtration systems. Triethylamine (Et<sub>3</sub>N) and pyridine were distilled from ninhydrin and CaH<sub>2</sub>. Final reaction mixture solutions were dried over Na<sub>2</sub>SO<sub>4</sub> or MgSO<sub>4</sub> and rotary-evaporated under vacuum. Melting points are uncorrected. Mass spectral data, HRMS/ESMS, were obtained by the Université de Montréal Mass Spectrometry facility. Unless otherwise noted, <sup>1</sup>H NMR (300/400 MHz) and <sup>13</sup>C NMR (75/100 MHz) spectra were recorded in CDCl<sub>3</sub>. Chemical shifts are reported in ppm (δ units) downfield of internal tetramethylsilane ((CH<sub>3</sub>)<sub>4</sub>Si) or residual solvent (CHCl<sub>3</sub> and MeOH). Coupling constants are reported in hertz (Hz). Chemical shifts of aromatic and vinylic carbons are not reported for the <sup>13</sup>C NMR spectra of PhF containing compounds. Analytical thin-layer chromatography (TLC) was performed using aluminum-backed silica plates coated with a 0.2 mm thickness of silica gel 60 F<sub>254</sub> (Merck KGaA Germany). Chromatography was performed using Kieselgel 60 (230-400 mesh).

### 3.4.2 Study of Carbenoid insertion into the $\gamma$ -amino NH bond using diazo $\beta$ -diketone and $\alpha$ -diazo $\beta$ -ketoester substrates

#### (2*S*)-*N*-Boc serine 3.25:

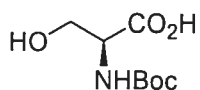

A solution of serine **3.24** (1.05 g, 10 mmol, 100 mol%) in a mixture of dioxane (20 mL) and water (10 mL) was treated with a solution of  $\text{Na}_2\text{CO}_3$  (1.16 g, 11 mmol, 110 mol%) in 10 mL of water, cooled in ice-water bath and treated with di-*tert*-butyl pyrocarbonate (2.4 g, 11 mmol, 110 mol%). The bath was removed, and stirring was continued at room temperature for 4.5 h. The solution was concentrated in *vacuo* to about 10-15 mL, cooled in an ice-water bath, covered with a layer of ethyl acetate (30 mL) and acidified with a dilute solution of  $\text{KHSO}_4$  to pH 2-3. The aqueous phase was extracted with ethyl acetate (3 x 10 mL). The combined organic phase was washed with water (2 x 30 mL), dried over anhydrous  $\text{Na}_2\text{SO}_4$  and evaporated to give *N*-(Boc)-serine **3.25** as a solid (1.90 g Yield 97%). mp 90-91 °C, lit. 91 °C;  $[\alpha]_D^{20}$  -3.13 (*c* 2,  $\text{CH}_3\text{CO}_2\text{H}$ ), lit.<sup>27</sup>  $[\alpha]_D^{20}$  -3.5  $\pm$  0.5° (*c* 2,  $\text{CH}_3\text{CO}_2\text{H}$ ).

#### (2*S*)-2-*tert*-Butoxycarbonylamino-3-(*tert*-butyl-diphenyl-silanyloxy)-propionic Acid 3.27:

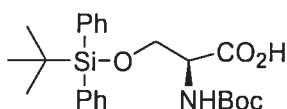

A solution of *N*-Boc serine **3.25** (1.5 g, 7.3 mmol, 100 mol%) in 1.8 mL of DMF at room temperature was treated with TBDPSCl (2.4 g, 8.76 mmol, 120 mol%) and imidazole (1.24 g, 18.25 mmol, 250 mol%), stirred for 36 h, treated with water (20 mL) and

extracted with ethyl acetate (3 x 100 mL), the organic layer was washed with water and brine, dried (Na<sub>2</sub>SO<sub>4</sub>), and evaporated. The residue was purified by chromatography eluting with 30-60% EtOAc in hexanes as eluent. Evaporation of the collected fractions provided silyl ether **3.10** as a solid (3.10 g, 96 % yield). mp 150-152 °C [ $\alpha$ ]<sup>20</sup><sub>D</sub> -13.4 ° (*c* 1.02, CHCl<sub>3</sub>) for *D*-serine lit,<sup>12</sup> mp 147-149 °C [ $\alpha$ ]<sup>20</sup><sub>D</sub> +12.3° (*c* 0.18, CHCl<sub>3</sub>) for *L*-serine; <sup>1</sup>H NMR (CDCl<sub>3</sub>, 300 MHz)  $\delta$  0.90 (s, 9H); 1.34 (s, 9 H); 3.77 (d, *J* = 3.8 Hz, 1H); 4.01 (d, *J* = 9, 5 Hz, 1H); 4.32 (d, *J* = 11.4 Hz, 1H); 5.30 (d, *J* = 11.5 Hz, 1H); 7.29-7.56 (m, 10 H). ESMS For C<sub>24</sub>H<sub>33</sub>NO<sub>5</sub>Si (M)<sup>+</sup> 443.2 HRMS calcd. For C<sub>24</sub>H<sub>34</sub>NO<sub>5</sub>Si (M+H)<sup>+</sup> 444.22008, found 444.22031.

**(2*S*)-2-*tert*-Butoxycarbonylamino-3-(*tert*-butyl-diphenyl-silanyloxy)-propionic Acid Methyl Ester 3.38:**

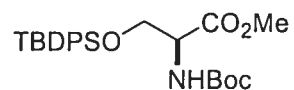

To a suspension of protected amino acid **3.27** (443.0mg, 1mmol, 100 mol%) and sodium hydrogen carbonate (168 mg, 2mmol, 200mol%) in dimethylformamide (DMF, 5 mL), methyl iodide (705 mg, 5 mmol, 500 mol%) in 5 mL of DMF was added at room temperature. The mixture was allowed to react for 24 h, then water (2 mL) was added and the mixture was extracted with ethyl acetate (2 x 10 mL). The organic layer was washed with water, dried with Na<sub>2</sub>SO<sub>4</sub>, evaporated to a small volume, and finally the product was purified by column chromatography using 10:90 ethyl acetate in hexanes as eluent. Evaporation of the collected fractions provided an oil (435 mg, 91% yield) of methyl ester **3.38**: [ $\alpha$ ]<sup>20</sup><sub>D</sub> +15.66° (*c* 0.44, CHCl<sub>3</sub>); <sup>1</sup>H NMR (CDCl<sub>3</sub>, 300 MHz)  $\delta$  1.01 (s, 9H); 1.43 (s, 9 H); 3.69 (s, 3H); 3.86 (dd, *J* = 9.9, 7.1 Hz, 1H); 4.04 (d, *J* = 9.9 Hz, 1H);

4.37 (m, 1H); 7.31-7.57 (m, 10 H).  $^{13}\text{C}$  NMR  $\delta$  14.2; 21.1; 29.4; 53.1; 61.9; 64.7; 74.9; (127.9-135.6); 158.2; 179.4. HRMS calcd. For  $\text{C}_{25}\text{H}_{36}\text{NO}_5\text{Si}$  ( $\text{M}+\text{H}$ ) $^+$  458.23573, found 458.23586.

**(3*S*)-[3-*tert*-Butoxycarbonylamino-4-(*tert*-butyl-diphenyl-silanyloxy)-2-oxo-butyl]-**

**Phosphonic Acid Dimethyl Ester 3.39:**

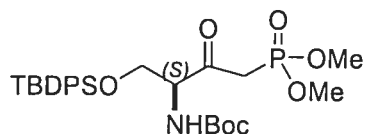

In a 50 mL round-bottom flask equipped with a magnetic stirring bar and rubber septum, under argon, a solution of dimethyl methyl phosphonate (569.2 mg, 4.6 mmol, 500 mol%) in THF (13 mL) was placed. The mixture was cooled to  $-78\text{ }^{\circ}\text{C}$  and treated by syringe with *n*-BuLi (2.23 mL, 4.5 mmol, 500 mol% solution in cyclohexane). After 15 min the mixture was transferred to a 50 mL round bottom flask containing a  $-78^{\circ}\text{C}$  solution of methyl ester **3.38** (435 mg, 0.92 mmol, 100 mol%) in THF (16 mL). After stirring at  $-78^{\circ}\text{C}$  for 2 h, the solution was quenched by addition of saturated  $\text{NH}_4\text{Cl}$  (4 mL), warmed to room temperature, diluted with  $\text{H}_2\text{O}$  (1.5 mL) and extracted with  $\text{Et}_2\text{O}$  (10 mL) and  $\text{EtOAc}$  (2 x 10 mL). The combined organic phases were washed with brine (5 mL), dried ( $\text{MgSO}_4$ ) and concentrated. The residue was dissolved in  $\text{CHCl}_3$  (10 mL), filtered, and concentrated to give a yellow oil, that was purified by column chromatography over silica gel using 80-100%  $\text{EtOAc}$  in hexanes as eluant. Evaporation of the collected fractions provided an oil (374 mg, 75% yield) of beta-keto phosphonate **3.39**:  $[\alpha]_{\text{D}}^{20} +35.8^{\circ}$  ( $c$  0.06,  $\text{CHCl}_3$ );  $^1\text{H}$  NMR ( $\text{CDCl}_3$ , 300 MHz)  $\delta$  0.96 (s, 9H); 1.36 (s, 9 H); 3.67 (d,  $J = 10.5$  Hz, 6H); 3.86 (dd,  $J = 10.6, 3.7$  Hz, 2H); 4.02 (m, 2H);



4.46(m, 1H); 7.29-7.56 (m, 10 H).  $^{13}\text{C}$  NMR  $\delta$  14.2; 19.3; 26.8; 28.4; 53.1 ; 61.9; 63.7; 79.9; (127.9-135.6); 155.2; 199.4 HRMS calcd. For  $\text{C}_{27}\text{H}_{41}\text{NO}_7\text{PSi}$  ( $\text{M}+\text{H}$ ) $^+$  550.23844, found 550.23864.

**(3S)-[3-*tert*-Butoxycarbonylamino-4-(*tert*-butyl-diphenyl-silanyloxy)-1-diazo-2-oxo-butyl]-Phosphonic Acid Dimethyl Ester 3.40:**

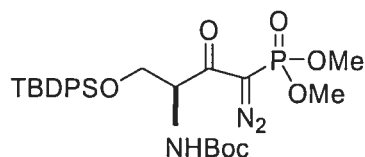

In a 50 mL round bottom flask equipped with a magnetic stirring bar, under argon, NaH (60% in mineral oil, 48.4 mg, 1.27 mmol) was washed with petroleum ether (2 x 5 mL). After removal of the petroleum ether by syringe, the flask was placed under vacuum for 2 min before THF (5.3 mL) was introduced by syringe. A solution of beta-keto phosphonate **3.39** (335 mg, 0.609 mmol) and 4-acetamidobenzenesulfonyl azide (4-ABSA) (144.8 mg, 0.602 mmol) in 13.5 mL THF was transferred via *cannula* quickly at room temperature to the round-bottom flask containing the NaH in THF. After stirring for 1.5 h, the reaction mixture was quenched by the addition of saturated aqueous  $\text{NH}_4\text{Cl}$  (2.6 mL), and extracted with  $\text{Et}_2\text{O}$  (20 mL) and  $\text{EtOAc}$  (2 x 20 mL). The combined organic phases were washed with brine (5 mL), dried and concentrated. The residue was purified by flash column chromatography over silica gel by using 35-50%  $\text{EtOAc}$  in hexanes as eluent. Evaporation of the collected fractions provided  $\alpha$ -diazo phosphonate **3.40** as an oil (240 mg, 72% yield):  $[\alpha]_{\text{D}}^{20} +20.97^\circ$  ( $c$  0.12,  $\text{CHCl}_3$ ); IR ( $\text{CHCl}_3$ )  $\nu_{\text{max}}$  ( $\text{cm}^{-1}$ ) 2957, 2118.52 ( $=\text{N}_2$ ); 1715, 1661, 1269 ( $\text{P}=\text{O}$ );  $^1\text{H}$  NMR ( $\text{CDCl}_3$ , 400 MHz)  $\delta$  1.03

(s, 9H); 1.42 (s, 9 H); 3.70 (dd,  $J = 25.8, 11.9$  Hz, 6H); 3.87 (m, 2H); 4.74 (m, 1H); 5.44 (d,  $J = 8.3$  Hz, 1H); 7.35-7.59 (m, 10 H).  $^{13}\text{C}$  NMR  $\delta$  19.4; 26.9; 28.5; 54.0 ; 57.66; 64.0; 80.2; (128.0-135.7); 155.3; 190.3 HRMS calcd. For  $\text{C}_{27}\text{H}_{39}\text{N}_3\text{O}_7\text{PSi}$  ( $\text{M}+\text{H}$ ) $^+$  576.22894, found 576.22841.

**(2S)-N-(Boc)-2-(tert-Butyl-diphenyl-silanyloxymethyl)-4-(dimethoxy-phosphonyl)-3-Azetidinone 3.41:**

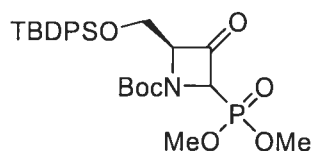

In a 25mL round bottom flask equipped with a magnetic stirring bar and reflux condenser, under argon, was added  $\alpha$ -diazo phosphonate **3.39** (70 mg, 0.121 mmol) and rhodium (II) acetate dimer (2.2 mg, 0.004 mmol) in  $\text{CH}_2\text{Cl}_2$  (3.5 mL). The mixture was stirred for 48 h at 35°C. The solvent was evaporated. The residue was treated with  $\text{H}_2\text{O}$  (4 mL) and extracted into EtOAc (2 x 5 mL). The combined organic phase was washed with brine (5 mL), dried, and concentrated to yellow oil 46 mg of **3.41**, which was used directly in the next step.  $^1\text{H}$  NMR ( $\text{CDCl}_3$ , 400 MHz)  $\delta$  1.03 (s, 9H); 1.46 (s, 9 H); 3.75 (dd,  $J = 9, 6$  Hz, 3H); 3.77 (d,  $J = 12$  Hz, 3H); 4.08 (d,  $J = 9$  Hz, 2H); 5.21 (m, 1H); 5.30 (m, 2H); 7.28-7.71 (m, 10 H).  $^{13}\text{C}$  NMR  $\delta$  19.4; 26.9; 28.5; 54.0; 57.6; 64.0; 72.4; 80.2; (128.0-135.7); 155.3; 190.3. ESMS for  $\text{C}_{27}\text{H}_{38}\text{NO}_7\text{PSi}$  ( $\text{M}+\text{Na}$ ) $^+$  570.0.

**(2*R*,4*R*)-2-[3-*tert*-Butoxycarbonyl-3-(9-phenyl-9H-flouren-9-ylamino)-propylidene]-4-(*tert*-butyl-diphenyl-silanyloxymethyl)-3-Azetidinone-1-Carboxylic Acid *tert*-Butyl Ester **3.43**:**

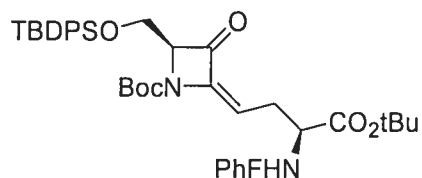

In a 25 mL, single neck round bottom flask equipped with a magnetic stirring bar and rubber septum, under argon, azetidine phosphonate **3.41** (55 mg, 0.1 mmol, 100 mol%) was dissolved in 3.2 mL of THF, cooled to 0 °C, treated with aldehyde **3.42** (41.3 mg, 0.1 mmol, 100mol%), prepared according to reference 28) followed by DBU (41.3mg, 0.2 mmol, 200mol%), stirred for 2.5 h and quenched by addition of saturated aqueous NH<sub>4</sub>Cl (1 mL). The solution was extracted with Et<sub>2</sub>O (25 mL). The combined organic phases were washed with brine (2 mL), dried, and concentrated. The residue was purified by chromatography eluting with 5-10% EtOAc in hexanes as eluent. Evaporation of the collected fractions provided  $\alpha,\beta$ -unsaturated ketone **3.43** a mixture of two *cis-trans* olefin isomers (according LC/MS) in a 3:1 ratio as assessed by measurement of the triplet signals at  $\delta$  4.78 and 4.73 ppm in the <sup>1</sup>H NMR spectrum, as a white foam (25.9 mg, 31% yield); [ $\alpha$ ]<sub>D</sub><sup>20</sup> -24.7° (*c* 0.02, CHCl<sub>3</sub>); for the major olefin isomer: <sup>1</sup>H NMR (CDCl<sub>3</sub>, 300 MHz)  $\delta$  0.98 (s, 9H); 1.19 (s, 9 H); 1.43 (s, 9H); 2.64-2.68 (m, 2H); 3.22-3.32 (bs, 1H); 4.12-4.19 (m, 2H); 4.78 (t, *J* = 3.1 Hz, 1H); 5.58 (t, *J* = 5.8 Hz, 1H); 7.20-7.65 (m, 23H). For the major olefin isomer: <sup>13</sup>C NMR  $\delta$  19.6; 26.8; 28.1; 28.5; 30.0; 33.5; 55.7; 60.1; 73.3; 81.1; 82.3; (119.9-149.4); 152.3; 174.6; 190.5.

For the minor olefin isomer:  $^1\text{H}$  NMR ( $\text{CDCl}_3$ , 300 MHz)  $\delta$  1.01(s, 9H); 1.20 (s, 9 H); 1.47 (s, 9H); 2.38-2.47 (m, 2H); 2.81-3.00 (bs, 1H); 3.97-4.05 (m, 2H); 4.73 (t,  $J = 2.3$  Hz, 1H); 5.53 (t,  $J = 5.3$  Hz, 1H); 7.20-7.65 (m, 23H). HRMS calcd. For  $\text{C}_{52}\text{H}_{58}\text{N}_2\text{O}_6\text{Si}$  ( $\text{M}+\text{H}$ ) $^+$  835.41369, found 835.41484.

### 3.4.3 Synthesis of 4-substituted Aze via $S_N2'$

#### 3.4.3.1 Synthesis of 4-propenyl Aze 3.48 from allylic alcohol 3.46 by $S_N2'$ displacement (2-Oxo-propyl)-Phosphonic Acid Dimethyl Ester 3.44:

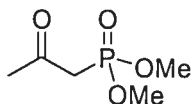

In a 250 mL flask was placed dimethyl methyl phosphonate (6.2 g, 50 mmol, 250 mol%) dissolved in THF (50 mL). The mixture was cooled to  $-78\text{ }^{\circ}\text{C}$ , treated with *n*-BuLi (20 mmol, 20 mL, 250 mol%, an 2.5 M solution in cyclohexane), stirred 30 min and treated dropwise with ethyl acetate (1.762 g, 20 mmol, 100mol%). After stirring for 3 h at  $-78\text{ }^{\circ}\text{C}$ , the reaction was quenched with 50 mL  $\text{NaH}_2\text{PO}_4$ , and warmed to room temperature. The mixture was treated with brine. The phases were separated. The aqueous phase was washed with EtOAc (5 x 50 mL), dried and evaporated. The residue was purified by distillation (bp  $76\text{-}79\text{ }^{\circ}\text{C}/3\text{mm}$ ) to give  $\beta$ -keto phosphonate **3.44** (2.8 g, 82% yield); bp  $78\text{-}80\text{ }^{\circ}\text{C}/3\text{mmHg}$  lit.<sup>29</sup> bp  $76\text{-}79\text{ }^{\circ}\text{C}/3\text{mmHg}$ ;  $^1\text{H}$  NMR ( $\text{CDCl}_3$ , 400 MHz)  $\delta$  2.09 (s, 3H); 2.87 (s, 1H); 2.94 (s, 1H); 3.54(s, 3H); 3.58 (s, 3H). ESMS For  $\text{C}_5\text{H}_{12}\text{O}_4\text{P}$  ( $\text{M}+\text{H}$ )<sup>+</sup> 167.0.

#### (2*S*)-6-Oxo-2-(9-phenyl-9H-fluoren-9-ylamino)-hept-4-enoic Acid *tert*-Butyl Ester 3.45:

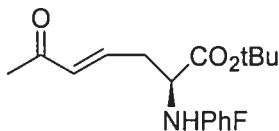

To a stirred solution of  $\beta$ -keto phosphonate **3.44** (200 mg, 1.2 mmol, 100 mol%) in  $\text{CH}_3\text{CN}$  (4.3 mL),  $\text{Cs}_2\text{CO}_3$  (410.7 mg, 1.2 mL, 105 mol%) was added. The suspension

was stirred for 30 minutes at r.t., cooled to 0 °C, treated with a solution of aldehyde **3.42** (497.4, 1.2 mmol, 100 mol%, prepared according to reference 28) in CH<sub>3</sub>CN (4.3 mL), stirred at r.t. for 3.5 h, diluted with EtOAc (15 mL) and quenched with NaH<sub>2</sub>PO<sub>4</sub> (3 mL, 1M). The layers were separated. The aqueous layer was extracted with EtOAc (2 x 30 mL). The combined organic phases were washed with brine, dried and evaporated to give a yellowish oil that was chromatographed using a gradient of 10-14% EtOAc in hexanes to afford  $\alpha,\beta$ -unsaturated ketone **3.45** as an oil (366 mg, 67% yield).  $[\alpha]_D^{20} -12.74^\circ$  (*c* 0.60, CHCl<sub>3</sub>); <sup>1</sup>H NMR (CDCl<sub>3</sub>, 300 MHz)  $\delta$  1.26 (s, 9H); 2.28 (s, 3H); 2.29-2.38 (m, 2H); 2.72 (t, *J* = 4.4 Hz, 1H); 3.31(s, 1H); 6.05 (d, *J* = 16 Hz, 1H); 6.72-6.80 (m, 1H); 7.20-7.74 (m, 13H). <sup>13</sup>C NMR  $\delta$  26.8; 28.0; 39.1; 55.7; 73.1; 81.4; (120.0-149.3); 174.1; 198.5. ESMS calcd. For C<sub>30</sub>H<sub>31</sub>NO<sub>3</sub>Na(M+Na)<sup>+</sup> 476.2. HRMS calcd. For C<sub>30</sub>H<sub>32</sub>NO<sub>3</sub> (M+H)<sup>+</sup>454.23767, found 454.23682.

**(2*S*)-6-Hydroxy-2-(9-phenyl-9H-fluoren-9-ylamino)-hept-4-enoic Acid *tert*-Butyl Ester **3.46**:**

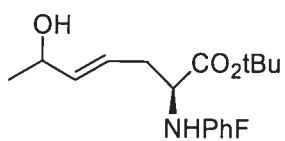

Ketone **3.45** (100 mg, 0.22 mmol, 100 mol%) was dissolved in 7.0 mL of a 0.4 M CeCl<sub>3</sub>·7H<sub>2</sub>O methanol solution, cooled to -15 °C, treated slowly with NaBH<sub>4</sub> (12.5 mg, 0.33 mmol, 150 mol%) and stirred for 2h at -15 °C. The reaction was quenched with H<sub>2</sub>O (0.5 mL), and extracted with Et<sub>2</sub>O (2 x 5 mL) and EtOAc (2 x 5 mL). The combined organic phases were washed with brine, dried (MgSO<sub>4</sub>) and concentrated to give a residue that was purified by column chromatography using an eluent of 15% EtOAc in

hexanes to furnish the alcohol **3.46** (82 mg, 81% yield) as a mixture of two diastereomers in a 4:1 ratio (confirmed by LC/MS).  $^1\text{H}$  NMR ( $\text{CDCl}_3$ , 400 MHz)  $\delta$  1.17 (s, 9H); 1.27 (d,  $J = 4.8$  Hz, 3H); 2.13 (dd,  $J = 13.4, 6.7$  Hz, 2H); 2.60 (dd,  $J = 12.7, 5.8$  Hz, 1H); 3.1 (bs, 1H); 4.25 (dd,  $J = 14.2, 6.2$  Hz, 1H); 5.45-5.55 (m, 1H); 5.59-5.72 (m, 1H); 7.21-7.67 (m, 13H).  $^{13}\text{C}$  NMR  $\delta$  23.44;( 23.49); 28.2; (38.84); 38.89; 56.4; (56.5); 68.9; (69.0); 73.2; 80.9; (120.0-149.7); 174.8.  $(\text{M}+\text{H})^+$  HRMS calcd. For  $\text{C}_{30}\text{H}_{33}\text{NO}_3$   $(\text{M}+\text{H})^+$  456.25332, found 456.25336.

**(2S)-2-(9-Phenyl-9H-fluoren-9-ylamino)-6-(toluene-4-sulfonyloxy)-hept-4-enoic Acid tert-Butyl Ester 3.47** and **N-(PhF) 3-Propenyl Azetidine 2-tert-Butyl Ester 3.48**:

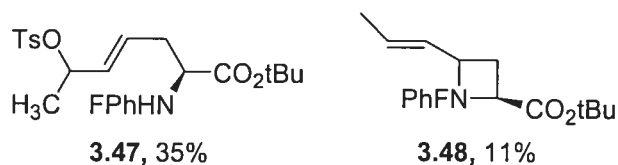

To a magnetically stirred solution of alcohol **3.46** (188 mg, 0.41 mmol 100 mol%) in 1.3 mL of  $\text{CH}_2\text{Cl}_2$  and 1.7 mL of pyridine cooled at  $0^\circ\text{C}$  was added solid *p*-toluene sulfonyl chloride (237.8 mg, 1.23 mmol, 300 mol%) in one portion. The mixture was stirred at  $0^\circ\text{C}$  for 2h and 22 h at r.t. The mixture was evaporated and was poured into ice water, and extracted with EtOAc (3 x 50 mL). The combined organic phases were washed with brine, dried over  $\text{MgSO}_4$ , filtered and concentrated. The organic solutions were combined and purified by column chromatography over silica gel using 3-15% EtOAc in hexanes as eluent. Evaporation of the collected fractions gave three fractions: 57 mg of starting material **3.46** (28%), and 21 mg of propenyl azetidine **3.48** (11%) and 77 mg of tosylate **3.47** (30%). Attempts for further purification of **3.47** and **3.48** were unsuccessful

and the  $^1\text{H}$  NMR and  $^{13}\text{C}$  NMR were complicated due to existence of two diastereomers and two olefin isomers and showed multiple signals for some protons and carbons in tosylate **3.47** and propenyl azetidine **3.48**.

Tosylate **3.47** was isolated as a 3:2 mixture of diastereomers as assessed by measurement of the diastereomeric doublet signals at  $\delta$  1.45 and 1.57 ppm in the  $^1\text{H}$  NMR spectrum.:  $\text{CDCl}_3$ , 400 MHz)  $\delta$  1.15 (s, 9H); 1.45 (d,  $J = 4.8$  Hz, 3H); 1.49 (d,  $J = 6.7$  Hz, 3H); 2.06 (t,  $J = 6.1$  Hz, 1H); 2.82-3.12 (m, 1H); 3.18 (bs, 1H); 4.62 (t,  $J = 7.6$  Hz, 1H); 4.81 (d,  $J = 6.7$  Hz, 1H); 5.31-5.56 (m, 2H); 7.11-7.67 (m, 17H).  $^{13}\text{C}$  NMR  $\delta$  19.1; (19.6); 21.2; (21.9); 30.2; 35.9; 36.8; 56.7; 66.2; (66.9); 71.3; (71.7); 126.2-149.4; 174.3; (174.8). ESMS  $m/z$   $\text{C}_{37}\text{H}_{40}\text{NO}_5\text{S}$  ( $\text{M}+\text{H}$ ) $^+$  610.2.

Azetidine **3.48** was isolated as a 7:5 mixture of diastereomers as assessed by measurement of the diastereomeric triplets at  $\delta$  3.43 and 3.25 ppm in the  $^1\text{H}$  NMR spectrum. The  $^1\text{H}$  NMR and  $^{13}\text{C}$  NMR in the vinylic region were complicated by olefin isomers and two diastereomers and showed multiple signals for some carbons. Spectral data for the major diastereomer:  $^1\text{H}$  NMR ( $\text{CDCl}_3$ , 400 MHz)  $\delta$  1.18 (s, 9H); 1.27 (d,  $J = 3.6$  Hz, 3H); 1.97-2.10 (m, 2H); 2.51 (t,  $J = 7.6$  Hz, 1H); 2.99 (s, 1H); 3.43 (t,  $J = 10.9$  Hz, 1H); 4.89-5.04 (2d,  $J = 13.2, 22.9$  Hz 1H total); 5.45-5.64 (m, 1H); 7.12-7.64 (m, 13H); for the minor isomer  $^1\text{H}$  NMR  $\delta$  1.11 (s, 9H); 1.45 (d,  $J = 3.6$  Hz, 3H); 1.77-1.95 (m, 2H); 2.51 (t,  $J = 7.6$  Hz, 1H); 2.99 (s, 1H); 3.24 (t,  $J = 10.4$  Hz, 1H); 4.69-4.81 (m, 1H); 4.89-5.04 (2d,  $J = 13.2, 22.9$  Hz 1H total); 5.31-5.39 (m, 1H); 7.12-7.64 (m, 13H);  $^{13}\text{C}$  NMR  $\delta$  17.0; 20.71;(20.78); 27.2; (27.4); 54.8; 55.1; (55.4); 72.3; 77.2; (119.0-140.1), 173.5; 173.6. HRMS calcd. For  $\text{C}_{30}\text{H}_{32}\text{NO}_2$  ( $\text{M}+\text{H}$ ) $^+$  438.4327, found 438.5218.

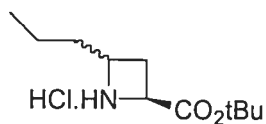

**4-Propyl-Azetidine-2-Carboxylic Acid *tert*-Butyl Ester 3.49:**

A solution of **3.48** (25 mg, 0.06 mmol, 100 mol %) in 2 mL of MeOH:HOAc (9:1) was transferred into a hydrogenation apparatus and treated with palladium-on-carbon (2 mg, 10 wt %). The pressure bottle was filled, vented, and refilled four times with 8 atm of H<sub>2</sub>. The reaction mixture was stirred (24 h), filtered onto a plug of Celite<sup>R</sup> 521(Aldrich USA), and washed thoroughly with MeOH. The filtrate was treated with 2 drops of 1N HCl and the volatiles were evaporated to give a crude residue of **3.49** (10.53 mg, 93% yield) as the hydrochloride salt which was purified by HPLC (HPLC, Prevail C18 5 μ, gradient 80-10% A:0.1 TFA in H<sub>2</sub>O, B: 20-90% 0.1 TFA in CH<sub>3</sub>CN; RT=12.5 min) recovery yield 56% of Azetidine **3.49** was observed to be a 3:2 ratio of diastereomers as assessed by measurement of the diastereomeric multiplet signals at δ 3.51 and 3.33 ppm in the <sup>1</sup>H NMR spectrum. Spectral data for the major diastereomer: <sup>1</sup>H NMR (CDCl<sub>3</sub>, 400 MHz) δ 0.88-0.95 (m, 3H); 1.19 (s, 9H); 1.33 (m, 2H); 1.82 -2.00 (m, 2 H), 2.53-2.60 (m, 1H), 3.08 (s, 1 H), 3.49-3.53 (m, 1H); 4.74-4.90 (m, 1H). For the minor isomer: <sup>1</sup>H NMR 0.88-0.95 (m, 3H); 1.26 (s, 9H); 1.58 (m, 2H); 2.10-2.23 (m, 2H), 2.53-2.60 (m, 1H), 3.08 (s, 1H), 3.32-3.34 (m, 1H); 4.58-4.60 (m, 1H). <sup>13</sup>C NMR δ 13.8; 19.8; (20.3); 28.2; 35.3; 37.1; (37.8); 48.5; (49.0); 62.9; (63.4); 84.6; (85.3); 166.6; (167.1). HRMS calcd. 200.16451 For C<sub>11</sub>H<sub>22</sub>NO<sub>2</sub> (M+H)<sup>+</sup>, found 200.16358.

### 3.4.3.2 Attempted synthesis of 4-substituted Aze **3.53** from allylic alcohol **3.51** by $S_N2'$ reaction

**(2*S*,7*R*)-7-*tert*-Butoxycarbonylamino-8-(*tert*-butyl-diphenyl-silanyloxy)-6-oxo-2-(9-phenyl-9*H*-fluoren-9-ylamino)-Oct-4-enoic acid *tert*-butyl ester **3.50**:**

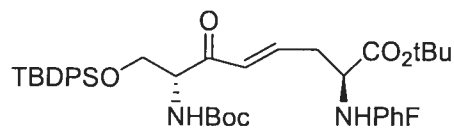

To a stirred solution of  $\beta$ -keto phosphonate **3.39** (655 mg, 1.19 mmol, 100 mol%) in  $\text{CH}_3\text{CN}$  (5 mL),  $\text{Cs}_2\text{CO}_3$  (388.3 mg, 1.19 mmol, 100 mol%) was added and the suspension was stirred for 30 min at room temperature, cooled to  $0^\circ\text{C}$  and treated with a solution of aldehyde **3.42** (491.4 mg, 1.19 mmol, 100 mol%, prepared according to reference 28) in  $\text{CH}_3\text{CN}$  (5 mL). The mixture was stirred at room temperature for 24 h, diluted with EtOAc (60 mL), and quenched with  $\text{NaH}_2\text{PO}_4$  (7.0 mL, 1M). The layers were separated, and the aqueous layer was extracted with EtOAc (2 x 20mL). The combined organic layers were washed with brine, dried, and evaporated to give yellowish oil that was chromatographed using a gradient of 3-6% EtOAc in hexanes to afford **3.50** as clear oil (710 mg and 72% yield).  $[\alpha]_D^{20} -30.85^\circ$  ( $c$  0.02,  $\text{CHCl}_3$ );  $^1\text{H NMR}$  ( $\text{CDCl}_3$ , 300 MHz)  $\delta$  1.03 (s, 9H); 1.21 (s, 9 H); 1.48 (s, 9H); 2.12-2.31 (m, 2H); 2.68 (t,  $J = 5.7$  Hz, 1H); 3.31 (s, 1H); 3.95-4.01 (m, 2H); 4.58-4.69 (dd,  $J = 7.0, 3.3$  Hz 1H); 5.62-5.72 (t,  $J = 7.7$  Hz, 1H); 6.2 (d,  $J = 15.8$  Hz, 1H), 6.79-7.04 (m, 1H); 7.20-7.72 (m, 23H).  $^{13}\text{C NMR}$   $\delta$  19.6; 27.1; 28.2; 28.7; 39.3; 55.9; 59.8; 64.6; 73.3; 79.9; 81.6; (120.1-149.4); 155.6; 174.3; 196.0. HRMS calcd. For  $\text{C}_{52}\text{H}_{61}\text{N}_2\text{O}_6\text{Si}$  ( $\text{M}+\text{H}^+$ ) 837.42934, found 837.43226.

**(2*S*,7*R*)-7-*tert*-Butoxycarbonylamino-8-(*tert*-butyl-diphenyl-silanyloxy)-6-hydroxy-2-(9-phenyl-9H-fluoren-9-ylamino)-Oct-4-enoic Acid *tert* -Butyl Ester **3.51**:**

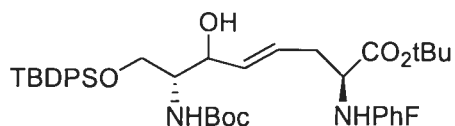

$\alpha,\beta$ -Unsaturated ketone **3.50** (335 mg, 0.4 mmol, 100 mol%) was dissolved in 20 mL of a solution of 0.4 M  $\text{CeCl}_3 \cdot 7\text{H}_2\text{O}$  in methanol, cooled to  $-15\text{ }^\circ\text{C}$ , treated slowly with  $\text{NaBH}_4$  (22.7 mg, 0.6 mmol, 150 mol%), stirred for 2h at  $-15\text{ }^\circ\text{C}$ , and quenched with  $\text{H}_2\text{O}$  (1 mL). The mixture was extracted with  $\text{Et}_2\text{O}$  (2 x 10 mL) and  $\text{EtOAc}$  (2 x 10 mL). The combined organic phases were washed with brine, dried ( $\text{MgSO}_4$ ) and concentrated to give a residue that was purified by column chromatography using an eluent of 10-15%  $\text{EtOAc}$  in hexanes to furnish alcohol **3.51** (263 mg, 78% yield) as a pure diastereomer (*E*-olefin isomer) (confirmed by LC/MS and  $^1\text{H}$  NMR) as a white foam;  $[\alpha]_D^{20} -65.8^\circ$  ( $c$  0.01,  $\text{CHCl}_3$ );  $^1\text{H}$  NMR ( $\text{CDCl}_3$ , 400 MHz)  $\delta$  1.11 (s, 9H); 1.22 (s, 9 H); 1.44(s, 9H); 2.12 (dd,  $J = 13.6, 6.5$ , Hz, 2H); 2.64 (dd,  $J = 11.6, 5.8$  Hz, 1H); 3.2 (bs, 1H); 3.71-3.77 (m, 2H); 3.83 (d,  $J = 4.1$  Hz, 1H); 3.92 (dd,  $J = 10.3, 3.6$  Hz, 1H); 4.30 (d,  $J = 4.8$  Hz, 1H); 5.2 (d,  $J = 8.1$  Hz, 1H); 5.5 (dd,  $J = 15.4, 5.8$  Hz, 1H), 5.77-5.87 (m, 1H); 7.20-7.71 (m, 23H).  $^{13}\text{C}$  NMR  $\delta$  14.1; 19.1; 26.7; 27.8; 28.2; 55.0; 55.9; 63.8; 72.9; 73.6; 79.2; 80.5; (119.5-149.3); 157.2; 174.4. HRMS calcd. For  $\text{C}_{52}\text{H}_{63}\text{N}_2\text{O}_6\text{Si}$  ( $\text{M}+\text{H}$ ) $^+$  839.44499, found 839.44499.

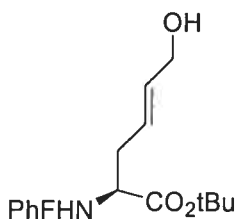
**3.4.3.3 Attempted synthesis of 4-vinyl Aze 3.59 from allylic alcohol 3.55****(2S)-6-Hydroxy-[N-(PhF)amino]-hex-4-enoic Acid *tert*-Butyl Ester 3.55:**

To a stirred solution of diester **3.54** (1g, 2.01 mmol, 100 mol%, prepared according to reference 16) in THF (40.5 mL) at -40 °C, DIBAL-H (1 M solution in toluene, 8.06 mmol, 400 mol%) was added. The mixture was stirred for 1.5 h, quenched with acetone (1.5 mL) diluted with MeOH (8 mL), and allowed to warm to room temperature and evaporated. The residue was dissolved in ether (50 mL) and extracted with 1 M NaOH (3 x 30 mL), washed with brine, dried (MgSO<sub>4</sub>), and evaporated. The residue was purified by column chromatography using 20% EtOAc in hexanes as eluent to yield 893 mg of **3.55** as oil (95% yield).  $[\alpha]_D^{20} -248.51^\circ$  (*c* 1.0, CHCl<sub>3</sub>); <sup>1</sup>H NMR (CDCl<sub>3</sub>, 400 MHz) δ 1.28 (s, 9H); 2.26 (t, *J* = 6.02 Hz, 2H); 2.42 (t, *J* = 7.21 Hz, 1H); 2.71-2.74(m, 1H); 4.12 (d, *J* = 4.24 Hz, 2H); 5.68-5.72 (m, 2H); 7.26-7.75 (m, 13H). <sup>13</sup>C NMR δ 28.0; 38.0; 76.1; 56.2; 63.4; 73.2; 80.8; (119.8-149.6); 174. HRMS calcd 442.2378 For C<sub>28</sub>H<sub>31</sub>NO<sub>3</sub> (M+H)<sup>+</sup> 442.2376.

**6-Methansulfonyloxy-*N*-PhF-hex-4-enoic Acid *tert*-Butyl Ester 3.57 and *N*(PhF)-1,2,3,4-tetrahydro-Pyridine-2-Carboxylic Acid *tert*-Butyl Ester 3.58:**

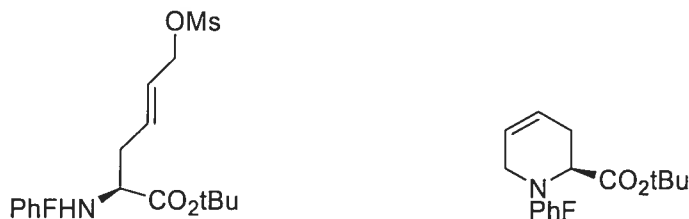

To an ice-cooled solution of alcohol **3.55** (589 mg, 1.33 mmol, 100 mol%), triethylamine (405.2 mg, 4.00 mmol, 300 mol%), DMAP (16.2 mg, 0.133 mmol, 10 mol%) in dichloromethane, methanesulfonyl chloride (304.5 mg, 2.66 mmol, 200 mol%) was added. The bath was removed and the mixture was allowed to warm to r.t. After 24h, the reaction mixture was diluted with water (15 mL) and extracted twice with EtOAc. The organic layers were washed with brine, dried and evaporated to a residue, that was chromatographed with 3-10% EtOAc in hexanes as eluent to give 297 mg of mesylate **3.57** (43% yield) and 214 mg of pipercolate **3.58** (38% yield).

Mesylate **3.57**: <sup>1</sup>H NMR (CDCl<sub>3</sub>, 400 MHz) δ 1.10 (s, 9H); 2.08 (t, *J* = 5.7 Hz, 2H); 2.51 (t, *J* = 8.08 Hz, 1H); 2.88 (s, 3H); 3.08-3.18 (bs, 1H); 4.57 (d, *J* = 8.8 Hz, 2H); 5.45-5.51 (m, 1H); 5.70-5.85 (m, 1H); 7.11-7.58 (m, 13H). <sup>13</sup>C NMR δ 28.0; 38.0; 76.1; 56.2; 63.4; 73.2; 80.8; (119.8-149.6); 174.8; ESMS *m/z* for C<sub>30</sub>H<sub>33</sub>NO<sub>5</sub>S (M<sup>+</sup>) 519.9.

Pipercolate **3.58**: [α]<sub>D</sub><sup>20</sup> -109.51° (*c* 0.06, CHCl<sub>3</sub>); <sup>1</sup>H NMR (CDCl<sub>3</sub>, 400 MHz) δ 1.11 (s, 9H); 2.07 (dd, *J* = 12.5, 6.2 Hz, 2H); 2.51 (t, *J* = 6.09 Hz, 1H); 3.92 (d, *J* = 6.8 Hz, 2H); 5.46-5.53 (m, 1H); 5.59-5.65 (m, 1H); 7.10-7.58 (m, 13H). <sup>13</sup>C NMR δ 28.1; 38.7; 45.4; 56.1; 73.2; 81.1; (120.0-149.6); 174.5. HRMS calcd. For C<sub>29</sub>H<sub>30</sub>NO<sub>2</sub> (M+H)<sup>+</sup> 424.2271, found 424.22537.

### 3.4.3.4 Synthesis of 4-vinyl Aze 3.65 via $S_N2'$ reaction of allylic chloride 3.64

#### (2*S*)-2-*tert*-Butoxycarbonylamino-pent-4-enoic Acid Methyl Ester 3.63:

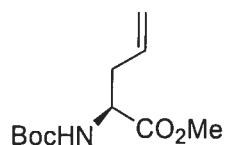

To a suspension of *N*-(Boc)allylglycine **3.62** (340mg, 1.58 mmol, 100mol% prepared according to reference 28, 20) and sodium hydrogen carbonate (265.5 mg, 3.16 mmol, 200mol%) in dimethylformamide (5 mL), methyl iodide (1.11 g, 7.9 mmol, 500 mol% in 5 ml DMF) was added at room temperature. The mixture was stirred for 24 h, treated with water (20 mL) and extracted with ethyl acetate (4 x 10 mL). The organic layer was washed with water, dried with  $\text{Na}_2\text{SO}_4$ , evaporated to a small volume that was purified by column chromatography using 10% ethyl acetate in hexanes as eluent. Evaporation of the collected fractions provided ester **3.63** as an oil (315 mg, 87 % yield).  $[\alpha]_D^{20} +15.75^\circ$  ( $c$  0.02,  $\text{CHCl}_3$ );  $^1\text{H NMR}$  ( $\text{CDCl}_3$ , 400 MHz)  $\delta$  1.33 (s, 9H); 2.39 (m, 2H); 3.61 (s, 3H); 4.27 (dd,  $J = 13.7, 6.2$  Hz, 1H); 5.04 (m, 3H); 5.57 (m, 1H).  $^{13}\text{CNMR}$   $\delta$  28.4; 36.7; 53.0 ; 54.5; 80.5; 119.5; 132.4; 155.8; 176.4. ESMS For  $\text{C}_{11}\text{H}_{20}\text{NO}_4$  ( $\text{M}+\text{H}$ ) $^+$  230.1 . HRMS calcd. For  $\text{C}_{11}\text{H}_{19}\text{NO}_4\text{Na}$  ( $\text{M}+\text{Na}$ ) $^+$  252.1206, found 252.1205.

#### (2*S*)-2-*tert*-Butoxycarbonylamino-6-chloro-hex-4-enoic Methyl Ester 3.64:

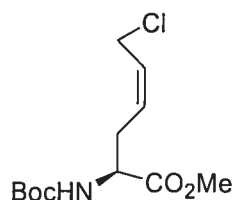

To a solution of *N*-(Boc)allylglycine methyl ester **3.63** (230 mg, 1.003 mmol, 100 mol%) and allyl chloride (307.2 mg, 4.015 mmol, 400 mol%) in  $\text{CH}_2\text{Cl}_2$  (17 mL), Grubbs second

generation catalyst benzylidene[1,3-bis(2,4,6-trimethylphenyl)-2-imidazolidinylidene]dichloro(tricyclohexylphosphine)ruthenium (87.6 mg, 0.1 mmol, 10 mol%) was added. The mixture was heated at reflux for 17 h. The solvents were evaporated under reduced pressure. The residue was chromatographed on silica gel using of 3-10% EtOAc in hexanes as eluent afforded **3.65** (172 mg, 62%) as a clear oil.  $[\alpha]_D^{20} +33.73$  (*c* 0.01, CHCl<sub>3</sub>). <sup>1</sup>H NMR (CDCl<sub>3</sub>, 400 MHz)  $\delta$  1.40 (s, 9 H); 2.40-2.47 (m, 1H); 2.52-2.58 (m, 1H); 3.72 (s, 3H); 3.98 (dd, *J* = 19.2, 8.2 Hz, 2H); 4.35 (dd, *J* = 13.2, 6.1 Hz, 1H); 5.07 (*J* = 7.7 Hz, 1H); 5.60-5.72 (m, 2H). <sup>13</sup>C NMR (CDCl<sub>3</sub>, 400 MHz)  $\delta$  27.5; 34.5; 43.7; 51.6; 52.1; 79.3; 128.3; 129.5; 154.3; 171.5. HRMS calcd. For C<sub>12</sub>H<sub>20</sub>ClNO<sub>4</sub>Na (M+Na)<sup>+</sup> 300.0973, found 300.0985.

***N*-(Boc)-4-Vinyl Azetidine 2-Methyl Ester 3.65:**

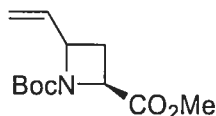

Under argon, allyl chloride methyl ester **3.64** (50 mg, 0.18 mmol, 100 mol %) was dissolved in THF (0.7 mL), cooled to -78 °C, treated dropwise with a solution of *n*-BuLi (0.07 mL, in cyclohexane, 2.5 M), stirred at -78 °C for 15 min, treated with silver triflate (74.2 mg, 0.28 mmol, 160 mol%) and the resulting light brown solution was allowed to warm to r.t. over 1.5h and stirred for an additional 1h. The resulting heterogeneous reaction mixture was diluted with ether, washed successively with 2N HCl, saturated NaHCO<sub>3</sub>, and brine, dried (MgSO<sub>4</sub>), and concentrated under reduced pressure to a residue that was chromatographed using 10-25% EtOAc in hexanes as eluant to provide vinyl azetidine **3.65** (12 mg, 25% yield) as a colorless oil; The <sup>1</sup>H NMR and <sup>13</sup>C NMR

were complicated by carbamate *cis* and *trans*-isomers and diastereomers of *N*-Boc 4-vinyl azetidine 2-methyl ester **3.65** and showed multiple signal for some carbons:  $^1\text{H}$  NMR ( $\text{CDCl}_3$ , 500 MHz, at 25 °C) in the vinylic region exhibited two *trans* and two *cis* in a 5.7:1 ratio as assessed by measurement of the *cis* doublet signals at  $\delta$  5.38 and 5.18 ppm.  $\delta$  1.50 (s, 9 H); 1.61-1.70 (m, 1H); 1.87-2.05 (m, 1H); 3.75 (s, 3H); 4.39-4.58 (m, 1H); 5.10 (bs, 1H); 5.20 and 5.35 (2d,  $J = 5.8, 8.2$  Hz, total 1H); 5.33 and 5.48 (2d,  $J = 14.2, 18.3$  Hz, total 1H); 5.78-5.91 (m, 1H).  $^1\text{H}$  NMR ( $\text{CDCl}_3$ , 500 MHz at -55 °C)  $\delta$  in the vinylic region exhibited two *trans* and two *cis* in a 2.7:1 ratio as assessed by measurement of the *cis* doublet signals at the same chemical shift as described above.  $\delta$  1.49 (s, 9 H); 1.60-1.71 (m, 1H); 1.90-2.15 (m, 1H); 3.81 (s, 3H); 4.52-4.61 (m, 0.5H); 4.83-4.92 (m, 0.5H); 5.18 (d,  $J = 14.3$  Hz, 1H); 5.20 (2d,  $J = 6.2, 6.5$  Hz, total 1H); 5.35, 5.50 (2d,  $J = 15.2, 17.8$  Hz, total 1H); 5.83-5.92 (m, 1H).  $^{13}\text{C}$  NMR ( $\text{CDCl}_3$ , 500 MHz at -55 °C)  $\delta$  28.3; 36.9; 41.3; 50.2; 51.2; 52.2; 53.5; 68.0; 78.5; 78.5; 81.0; 81.3; 115.2; 120.7; 134.0; 134.2; 138.7; 155.4; 157.0; 173.5; 175.6.  $^{13}\text{C}$  NMR ( $\text{CDCl}_3$ , 500 MHz at 25 °C) 28.5; 35.0; 37.4; 41.4; 51.0; 51.7; 52.9; 68.6; 78.4; 80.9; 114.9; 119.4; 134.7; 139.8; 156.9; 173.4. HRMS calcd. For  $\text{C}_{12}\text{H}_{20}\text{NO}_4$  ( $\text{M}+\text{H}$ ) $^+$  242.10038, found 242.10159.



### 3.4.4 Attempted synthesis of 4-substituted Aze via intramolecular nucleophilic ring opening of an epoxide:

#### (2S)-2-*tert*-Butoxycarbonylamino-3-oxiranyl-Propionic Acid Methyl Ester **3.70**:

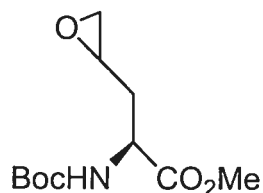

To a stirred solution of *N*-Boc allylglycine **3.63** (100mg, 0.436 mmol, 100 mol%, prepared according to reference 19) in CH<sub>2</sub>Cl<sub>2</sub> was added *m*-chloroperbenzoic acid (*m*-CPBA, 370 mg, 2.13 mmol, 490 mol%). After 5 h, the mixture was filtered through a glass filter, the solids were washed with CH<sub>2</sub>Cl<sub>2</sub>, and the combined organic filtrate and washings were cooled to 0 °C and washed with Na<sub>2</sub>SO<sub>3</sub> (2 mL). The mixture was filtered and organic phase was washed with 10% Na<sub>2</sub>SO<sub>3</sub>, 10% NaHCO<sub>3</sub> and water. After drying (MgSO<sub>4</sub>), filtration and evaporation of the volatiles, the residue was chromatographed on silica gel using a gradient of 20:80 EtOAc in hexanes to afford a mixture of two diastereomers of epoxide **3.70** in a 4:1 ratio (according to LC/MS) as clear oil (70 mg, 70% yields). <sup>1</sup>H NMR (CDCl<sub>3</sub>, 300 MHz) δ 1.29 (s, 9 H); 1.60-1.75 (m, 1H); 1.88-2.11 (m, 1H); 2.33 (dd, *J* = 4.8, 2.6 Hz, 1H); 2.62 (dd, *J* = 7.2, 3.9 Hz, 1H); 2.84-2.87 (m, 1H); 3.60 (s, 3H); 4.29 (t, *J* = 6.9 Hz, 1H); 5.17 (s, 1H); <sup>13</sup>C NMR δ 28.6; 35.7; (35.9); 46.8; (47.0); 49.4; 52.1; 52.8; 76.9; 155.5; (155.9); 172.8. HRMS calcd. For C<sub>11</sub>H<sub>20</sub>NO<sub>5</sub> (M+H)<sup>+</sup> 246.1342, found 246.1342.

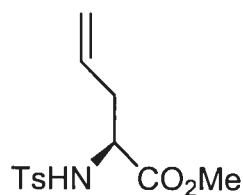
**(2S)-2-(Toluene-4-sulfonylamino)-pent-4-enoic Acid Methyl Ester 3.73:**

To a solution of allylglycine methyl ester hydrochloride **3.72** (20 mg, 0.119 mmol, 100 mol %, prepared according to reference 6) in  $\text{CH}_2\text{Cl}_2$  (1.4 mL), pyridine (18.8 mg, 0.238 mmol, 200 mol%) followed by *p*-toluene sulfonyl chloride (23 mg, 0.119 mmol, 100 mol%) were added. The mixture was stirred for 36 h at room temperature, and then washed with brine and water. After drying ( $\text{MgSO}_4$ ) and concentration of the volatiles, the residue was chromatographed on silica gel using a gradient of 15-20% EtOAc in hexanes to give sulfonamide **3.73** as an oil (27 mg, 80% yield)  $[\alpha]_D^{20} +11.12$  (*c* 0.04,  $\text{CHCl}_3$ ).  $^1\text{H}$  NMR ( $\text{CDCl}_3$ , 400 MHz)  $\delta$  2.41 (s, 3H); 2.45 (t,  $J = 6.6$  Hz, 2H); 3.51 (s, 3H); 4.01-4.04 (m, 1H); 5.05-5.10 (m, 2H); 5.22 (d,  $J = 8.9$  Hz, 1H); 5.58-5.62 (m, 1H); 7.26-7.72 (m, 4H).  $^{13}\text{C}$  NMR ( $\text{CDCl}_3$ , 400 MHz)  $\delta$  21.8; 37.8; 52.7; 55.5; 120.0; 127.5; 129.9; 131.5; 137.0; 144.0; 171.6. ESMS  $m/z$  284.0 For  $\text{C}_{13}\text{H}_{17}\text{NO}_4\text{S}$  ( $\text{M}+\text{H}$ ) $^+$ . HRMS calcd. For  $\text{C}_{13}\text{H}_{17}\text{NO}_4\text{S}$  ( $\text{M}+\text{H}$ ) $^+$  284.09511, found 284.09570.

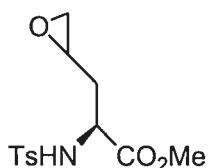
**(2S)-3-Oxiranyl-2-(toluene-4-sulfonylamino)-Propionic Acid Methyl Ester 3.74:**

Epoxide **3.74** was synthesized according to the procedure described for the synthesis of

epoxide **3.70** above using *N*-toluenesulfonyl allyglycine methyl ester **3.73** (50 mg, 0.176 mmol, 100 mol %) in CH<sub>2</sub>Cl<sub>2</sub> (2 mL) and *m*-chloroperbenzoic acid (*m*-CPBA, 370 mg, 2.13 mmol, 500 mol%). The residue was purified on silica gel using a gradient of 20-35% EtOAc in hexanes afforded a mixture 1:1 of two diastereomers in a ratio 1:1 as assessed by measurement of the diastereomeric methyl ester singlet at  $\delta$  3.52 and 3.56 ppm in the <sup>1</sup>H NMR spectrum **3.74** as white solid (38 mg, 72% yields). <sup>1</sup>H NMR (CDCl<sub>3</sub>, 400 MHz)  $\delta$  1.81-2.10 (m, 2H); 2.41 (s, 3H); 2.49 (t, *J* = 5.3 Hz, 1H); 2.73-2.77 (m, 1H); 2.92-3.02 (m, 1H); 3.52 (s, 3H); 4.12 (t, *J* = 6.2 Hz, 1H); 5.52 (d, *J* = 7.8 Hz, 1H); 7.26-7.74 (m, 4H). <sup>13</sup>C NMR  $\delta$  21.8; 36.4; 36.8; 47.1; 47.3; 48.6; 49.1; 49.0; 53.0; 53.1; 53.8; 54.1; 127.5; 129.9; 130.0; 136.6; 136.8; 144.1; 171.6; 171.8. HRMS calcd. for C<sub>13</sub>H<sub>18</sub>NO<sub>5</sub> S (M+H)<sup>+</sup> 300.0900, found 300.0908.

### 3.5 References:

- 1) Cluzeau, J.; Lubell, W. D. *Biopolymers (Peptide Science)* **2005**, *80*, 98.
- 2) Halab, L.; Gosselin, F.; Lubell, W. D. *Biopolymers (Peptide Science)* **2000**, *55*, 101.
- 3) 'The chemistry of  $\beta$ -lactam' Ed. M.I. page, Blackie Academic & Professional, London, 1992, 233-285.
- 4) Baldwin, R. M.; Adlington, R. H.; Jones, R. H.; Schofield C.; Zaracostas, C. *Tetrahedron* **1986**, *42*, 4879.
- 5) Polech, J.; Seebach, D. *Helv. Chim. Acta* **1995**, *78*, 1238.
- 6) Moyer, M. P.; Feldman, P. L.; Rapoport, H. *J. Org. Chem.* **1985**, *50*, 5223.
- 7) Frigola, J.; Torrens, A.; Castrillo, J. A.; Salgado, J.; Quintana, J. R. *J. Med. Chem.* **1994**, *57*, 4195.
- 8) Axenrod, T.; Watnick, C.; Yazdikhasti, H. *J. Org. Chem.* **1995**, *60*, 1959.
- 9) Hanessian, S.; Fu, J.; Chiara, J. L.; Di Fabio, R. *Tetrahedron Lett.* **1993**, *34*, 4157.
- 10) Eustache, J.; Van de Weghe, P.; Le Nouen, D.; Uyehara, H.; Kabuto, C.; Yamamoto, Y. *J. Org. Chem.* **2005**, *70*, 4043.
- 11) Doyle, M. P.; McKervey, M.A.; Ye, T. *Modern Catalytic Methods for Organic Synthesis with Diazo Compounds: from Cyclopropanes to Ylides*; John Wiley and Sons: New York, 1998.
- 12) Emmer, G. *Tetrahedron* **1992**, *48*, 7165.
- 13) Hanessian, S.; Fu, J. *Can. J. Chem.* **2001**, 1812.
- 14) Burtoloso, Antonio C. B.; Correia, Carlos, R. D. *Tetrahedron Lett.* **2004**, *45*, 3355.
- 15) Davis, F., A.; Wu, Y.; Xu, H.; Zhang, J. *Org. Lett.* **2004**, *6*, 4523.
- 16) Gosselin, F.; Lubell, W. D. *J. Org. Chem.* **1998**, *63*, 7463.

- 17) Takao, K. I.; Nigawara, Y.; Nishino, E.; Takagi, I.; Koji, M.; Tadano, K. I.; Ogawa, S. *Tetrahedron* **1994**, *50*, 5681.
- 18) Hirai, Y.; Watanabe, J.; Nozaki, T.; Yokoyama, H. Yamaguchi, S. *J. Org. Chem.* **1997**, *62*, 776.
- 19) Yokota, W.; Shindo, M.; Shishido, K. *Heterocycles* **2001**, *54*, 871.
- 20) Kaul, K.; Surprenant, S.; Lubell, W. D. *J. Org. Chem.* **2005**, *70*, 3838.
- 21) Swarbrick, M. E.; Gosselin, F.; Lubell, W. D. *J. Org. Chem.* **1999**, *64*, 1993.
- 22) Kaul, R.; Brouillette, Y.; Sajjadi, Z.; Hansford, K. A.; Lubell, W.D. *J. Org. Chem.* **2004**, *69*, 6131.
- 23) Toda, T. Karikomi, M.; Oshima, M.; Yoshida, M.; *Heterocycles*, **1992**, *33*, 511.
- 24) Karikomi, M.; Arai, K.; Toda, T. *Tetrahedron Lett.* **1997**, *38*, 6059.
- 25) Christe, B. D.; Rapoport, H. *J. Org. Chem.* **1985**, *50*, 1239.
- 26) For review see: a) Lohray, B. B. *Synthesis* **1992**, 1035. b) Kolb, H. C.; Van Nieuwenhze, M. S.; Sharpless, K. B. *Chem. Rev.* **1994**, *94*, 2483.
- 27) Sigma-Aldrich 2006 catalog, page 409.
- 28) Swarbrick, M. E.; Gosselin, F.; Lubell, W. D. *J. Org. Chem.* **1999**, *64*, 1993.
- 29) Sigma-Aldrich 2006 catalog, page 1011.

## **CHAPTER 4**

### **Conclusions and Perspectives**

## 4.1 Conclusion, future work and perspectives:

Incorporation of conformational constraints, such as a proline or proline homologue, into a biologically active peptide can enhance receptor selectivity and modulate ligand efficacy. With this aim we have developed methodologies for the synthesis of 3- and 4-substituted azetidine-2-carboxylic acids to serve as tools for studying the conformational requirements of biologically active peptides.

In Chapter 2, enantiopure 3-substituted azetidine-2-carboxylic acids containing different heteroatomic side chains were synthesized from L-Asp as chiral educt. 3-Substituted Aze analogues were prepared to serve as azetidine amino acid chimeras of Lys, nor-leucine and amino adipate. In light of the activity of 3-carboxymethyl Aze (*t*-CAA) **1.36**, a Glu-Aze chimera, to inhibit excitatory amino acid transporters, the potential for amino adipate-Aze **2.4** to exhibit activity merits investigation and may now be explored, because of our efficient synthesis.

In Chapter 3, preliminary experiments were made to prepare 2,4-disubstituted azetidines. For example, 4-substituted azetidine 2-phosphonate **3.41** was synthesized starting from L-serine **3.38** by a route featuring an intramolecular diazo insertion reaction of  $\alpha$ -diazo  $\beta$ -ketophosphonate **3.40**. This Aze analogue may be considered as a mimic of the corresponding  $\alpha$ -aminocarboxylic acid and was used in Wittig chemistry to provide 2,4-disubstituted azetidine-3-one **3.43**. A potential application of 2,4-disubstituted azetidine-3-one **3.43** as an intermediate for the synthesis of target azabicyclo[4.2.0]alkane amino acid **3.12** is illustrated in Scheme 4.1.

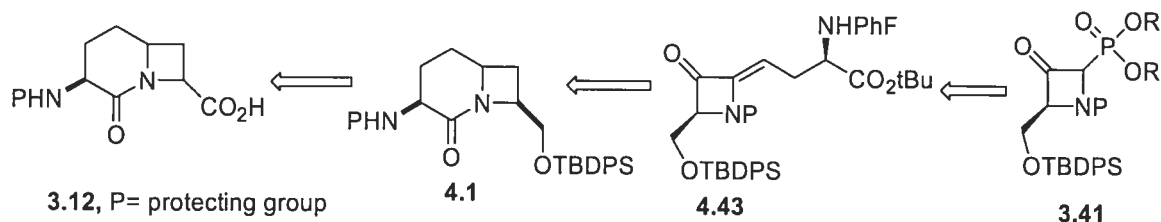

Scheme 4.1: Retro synthesis of target azabicyclo[4.2.0]alkane amino acid **3.12** from azetidione phosphonate **3.41**.

Another investigation to synthesize 4-substituted Aze analogues via  $S_N2'$  reaction, has produced 4-propenyl Aze analogue **3.48** as a diastereomeric mixture. Moreover, a novel pipercolate **3.58** was prepared as an interesting alternative product to 4-vinyl *N*-(PhF)Aze **3.59** when DMAP was used in the  $S_N2'$  reaction. 4-vinyl Aze **3.65** was synthesized using Ag(I) to effect the intramolecular  $S_N2'$  *N*-alkylation of **3.64**. 4-Vinyl Aze **3.65** may serve as precursor for the preparation of fused azabicyclo[5.2.0]alkane amino acid **3.13**, a novel  $\beta$ -turn mimic (Scheme 4.2).

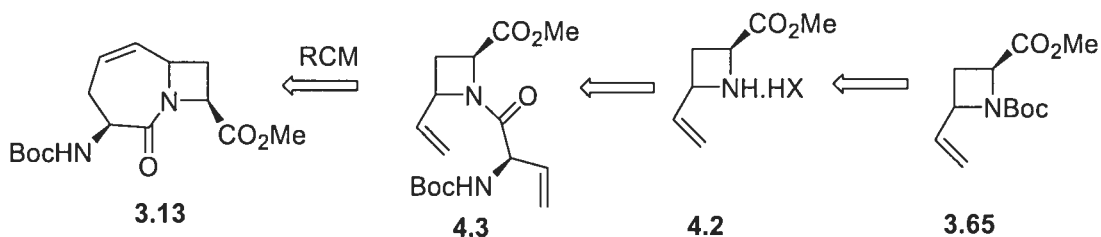

Scheme 4.2: Retro synthesis of target azabicyclo[5,2,0]alkane **3.13** from vinyl azetidione **3.65**.

In this route, the key step would be *N*-acylation of 4-vinyl Aze **3.65** to provide dipeptide **4.3** for ring-closing metathesis and construction of  $\beta$ -lactam **3.13**.



Although an investigation failed to produce 4-substituted Aze by intramolecular ring opening of an epoxide by nucleophilic attack of a  $\beta$ -amine, new amino epoxides **3.70**, **3.74** were synthesized for the first time from L-Asp. These novel amino epoxides could be considered as intermediates for synthesis of functionalized compounds such as amino alcohols.<sup>5</sup>

This research has thus touched on the field of peptide mimicry by providing new methodology and design for the synthesis of conformationally constrained compounds that may induce turn motifs when introduced into peptides and proteins. The important roles turns play in peptide recognition and biological activity suggest that the 3- and 4-substituted Aze analogues have interesting potential for studying conformation-activity relationships effecting potency, metabolic stability, and activity of biologically active peptides in medicinal chemistry and peptide science. Approaches for synthesizing 4-substituted azetidinone **3.43** and 4-substituted Aze analogues **3.48** and **3.65** offer potential for the construction of azabicyclo[X.2.0]alkane amino acids such as **3.12** and **3.13**. Future work on the synthesis of fused ring systems such as **3.12** and **3.13** will require improved methods for 4-substituted Aze synthesis. In this light, the described methods for making 3- and 4-substituted Aze analogues provides a solid foundation for the research activity of future colleagues.

## 4.2 References:

- 1) Chamberlin, A. R.; Bridges, R. J.; *In drug design for neuroscience*; Kozikowski, A. Ed.; Raven: New York, **1993**; pp 231-259.
- 2) Carrigan; C. N.; Esslinger, C.N.; Bartlett, R., D.; Bridges, R. J.; Thompson, C. M. *Bioorg. Med. Chem. Lett.* **1999**, *9*, 2607.
- 3) Denton, T. T.; Seib, T.; Bridges, R.J.; Thompson, C. M. *Bioorg. Med. Chem. Lett.* **2002**, *12*, 3209.
- 4) Kozikowski, A. P.; Liao, Y.; Tuckmantel, W.; Wang, S.; Pshenichkin, S.; Surin, A.; Thomsen, C.; Wroblewski, T. *Bioorg. Med. Chem. Lett.* **1996**, *6*, 2559.
- 5) Ngoctam, N. T.; Magueur; G.; Ourevitch, M.; Crousse, B.; Bonney-Delpon, D. *J. Org. Chem.* **2005**, *70*, 699.

## Appendix 1

### **$^1\text{H}$ NMR and $^{13}\text{C}$ NMR of compounds related to chapter 2**

Sajjadi, Z; Lubell, W. D., "Amino Acid-Azetidine Chimeras: Enantiopure 3-Substituted Azetidine-2-Carboxylic Acids", *J. Peptide. Res.* **2005**, *65*, 298-310.

**Appendix 2**

**$^1\text{H}$  NMR and  $^{13}\text{C}$  NMR and HRMS of compounds related to  
chapter 3**

## Appendix 1

### **$^1\text{H}$ NMR and $^{13}\text{C}$ NMR of compounds related to chapter 2**

Sajjadi, Z; Lubell, W. D., "Amino Acid-Azetidine Chimeras: Enantiopure 3-Substituted Azetidine-2-Carboxylic Acids", *J. Peptide. Res.* **2005**, *65*, 298-310.

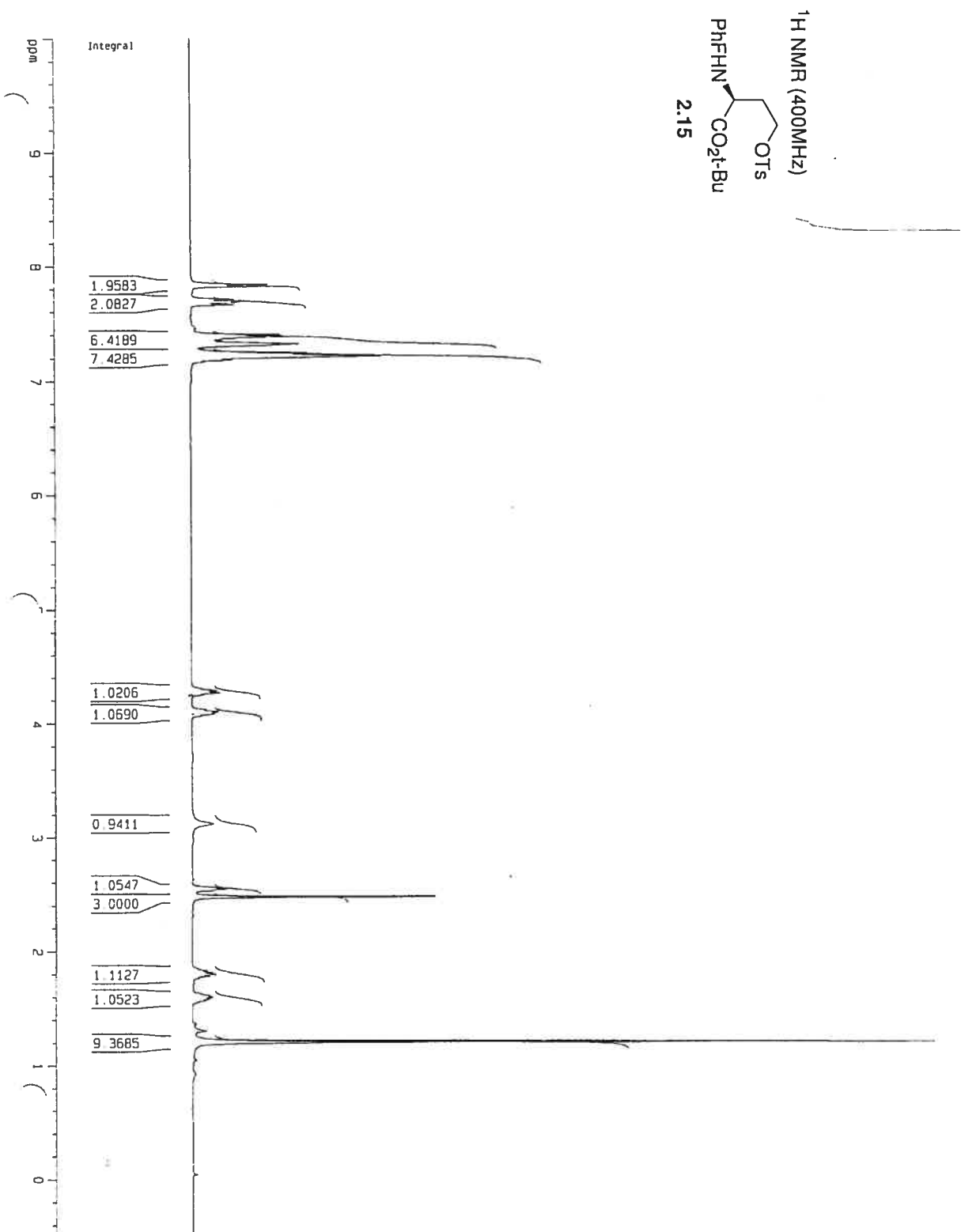

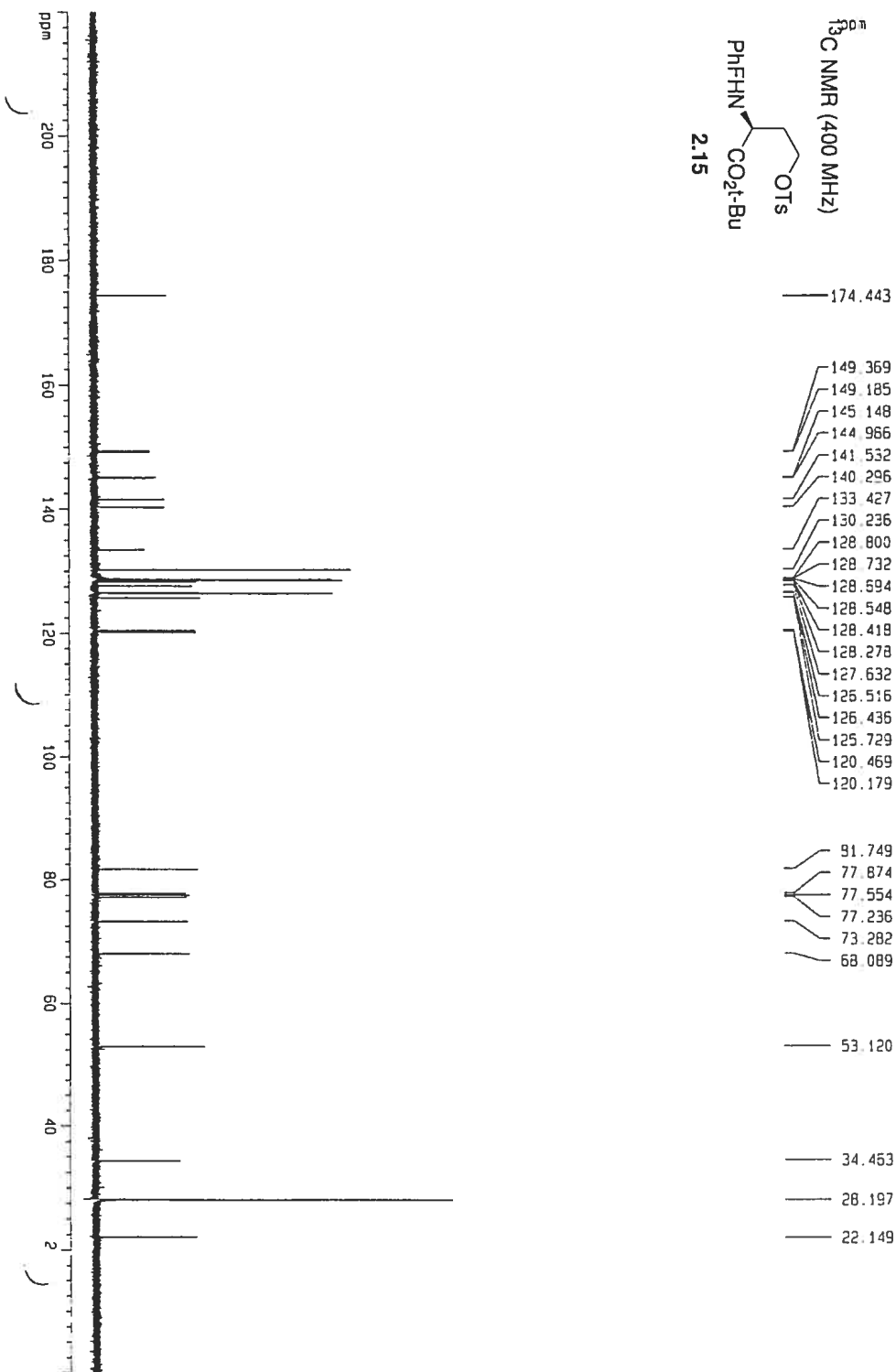

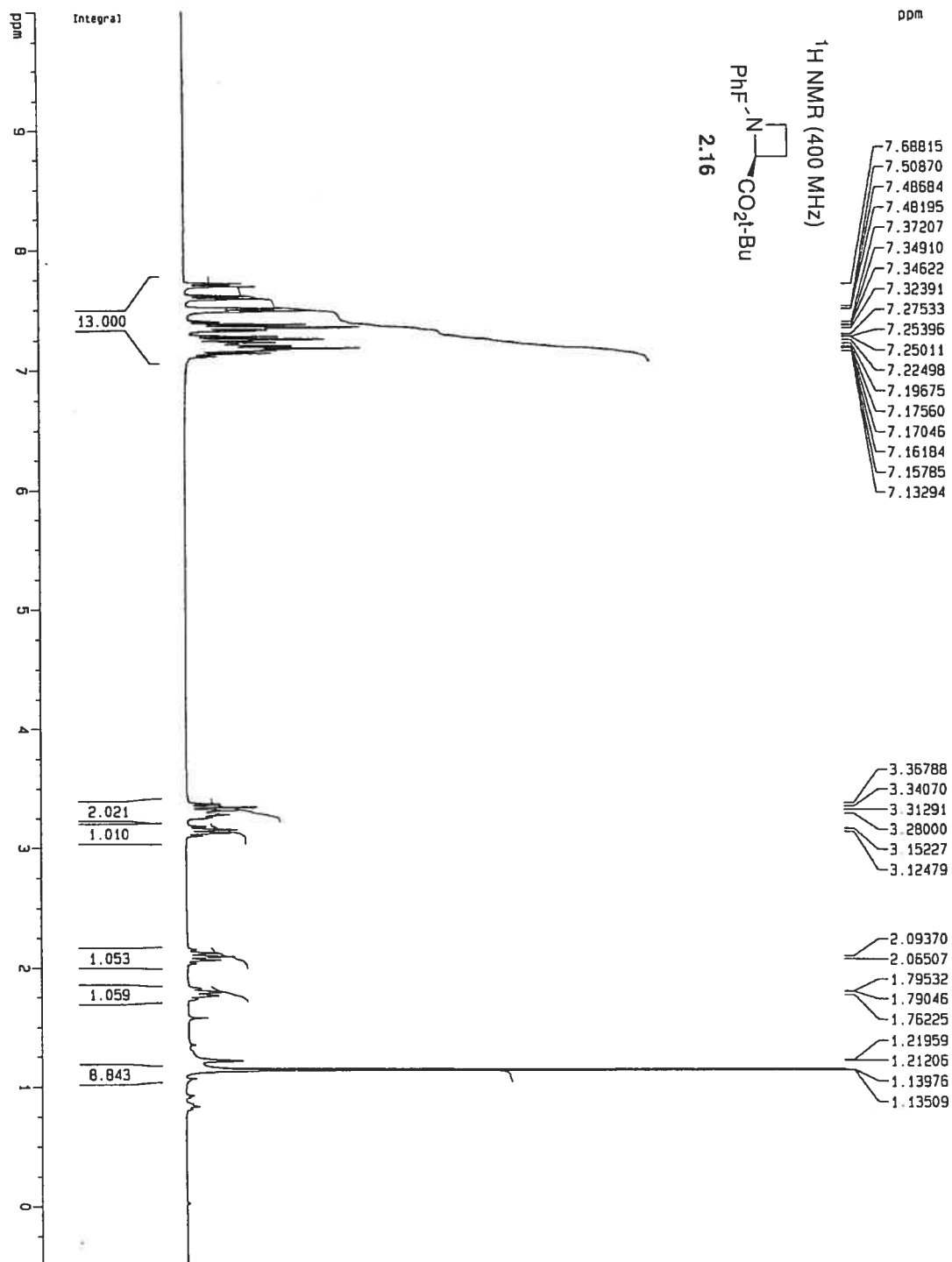



<sup>13</sup>C NMR (400 MHz)

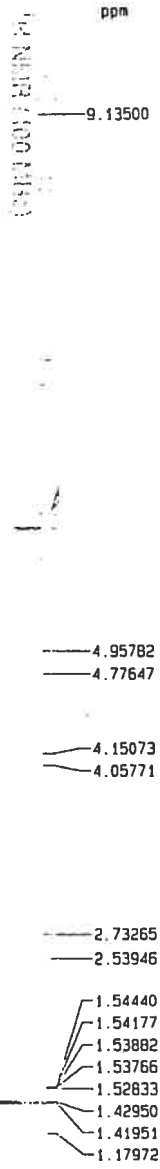
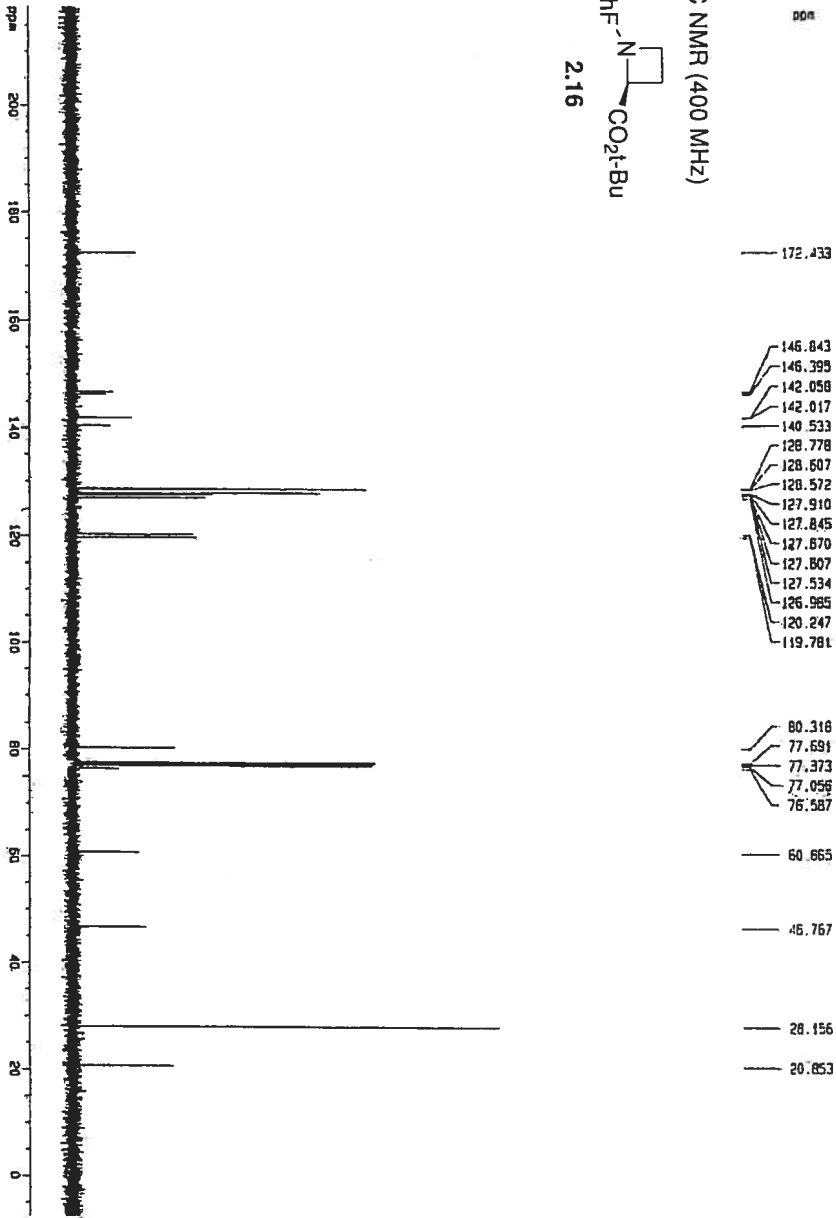
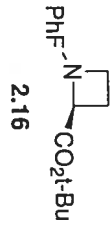

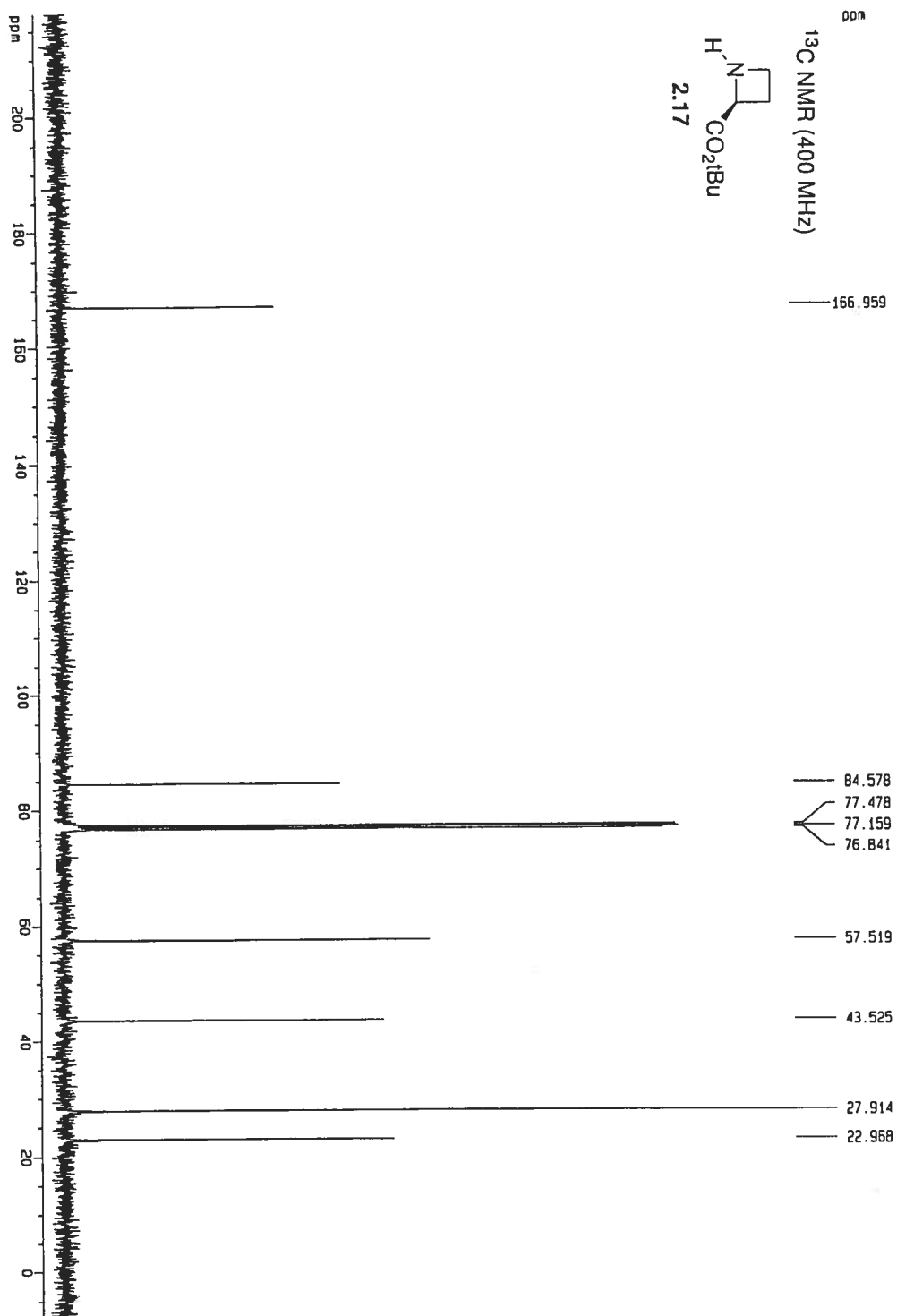

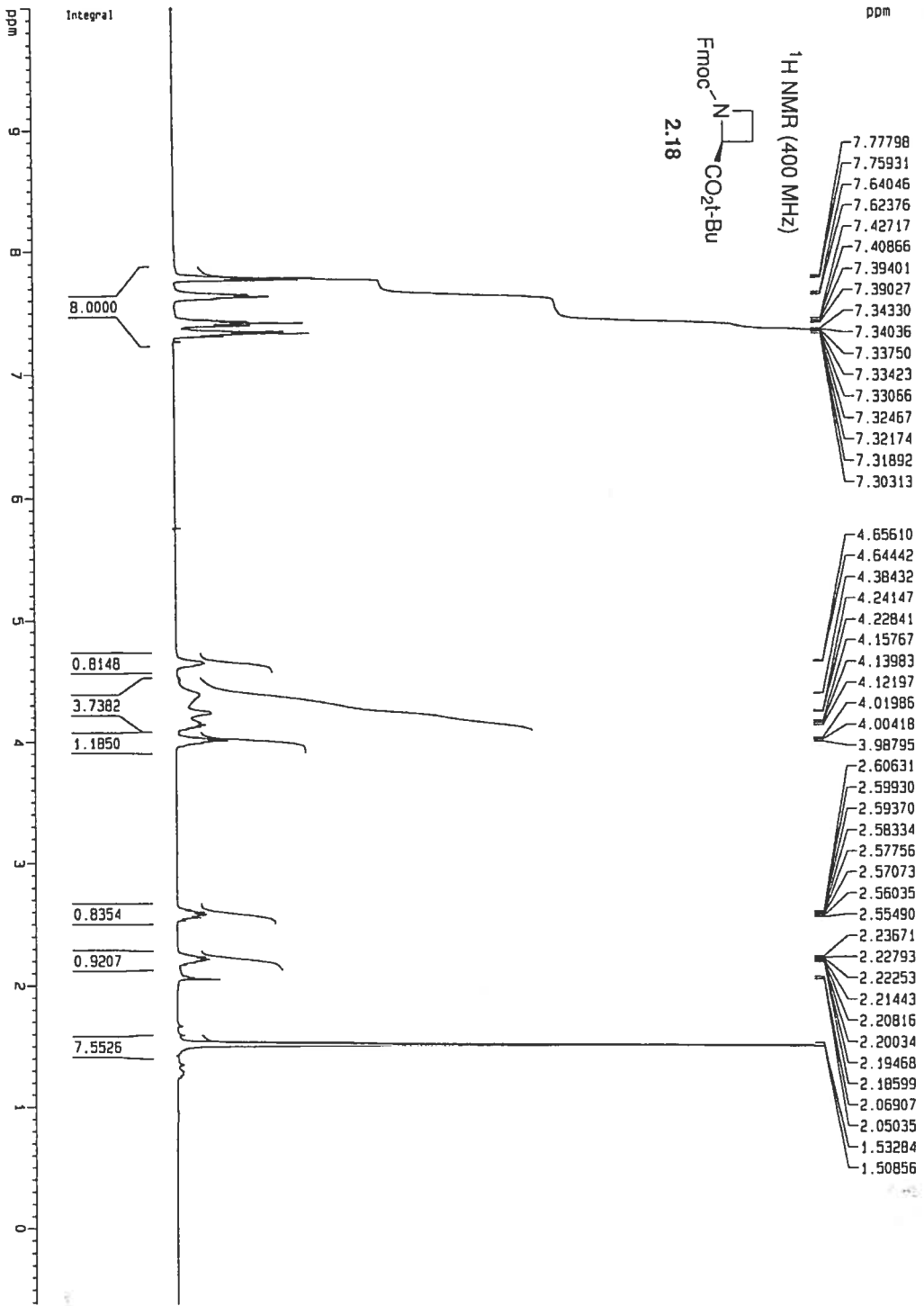

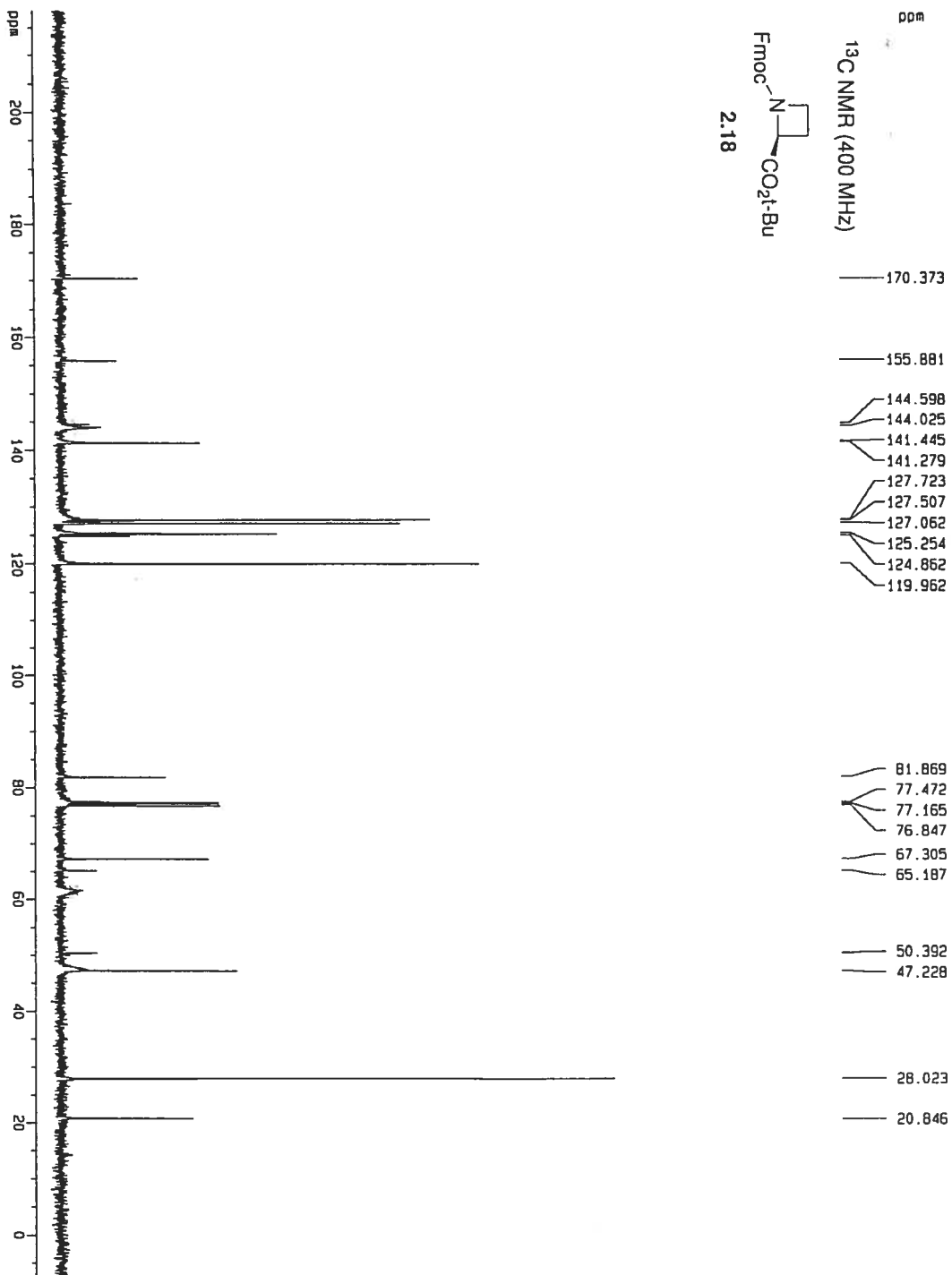

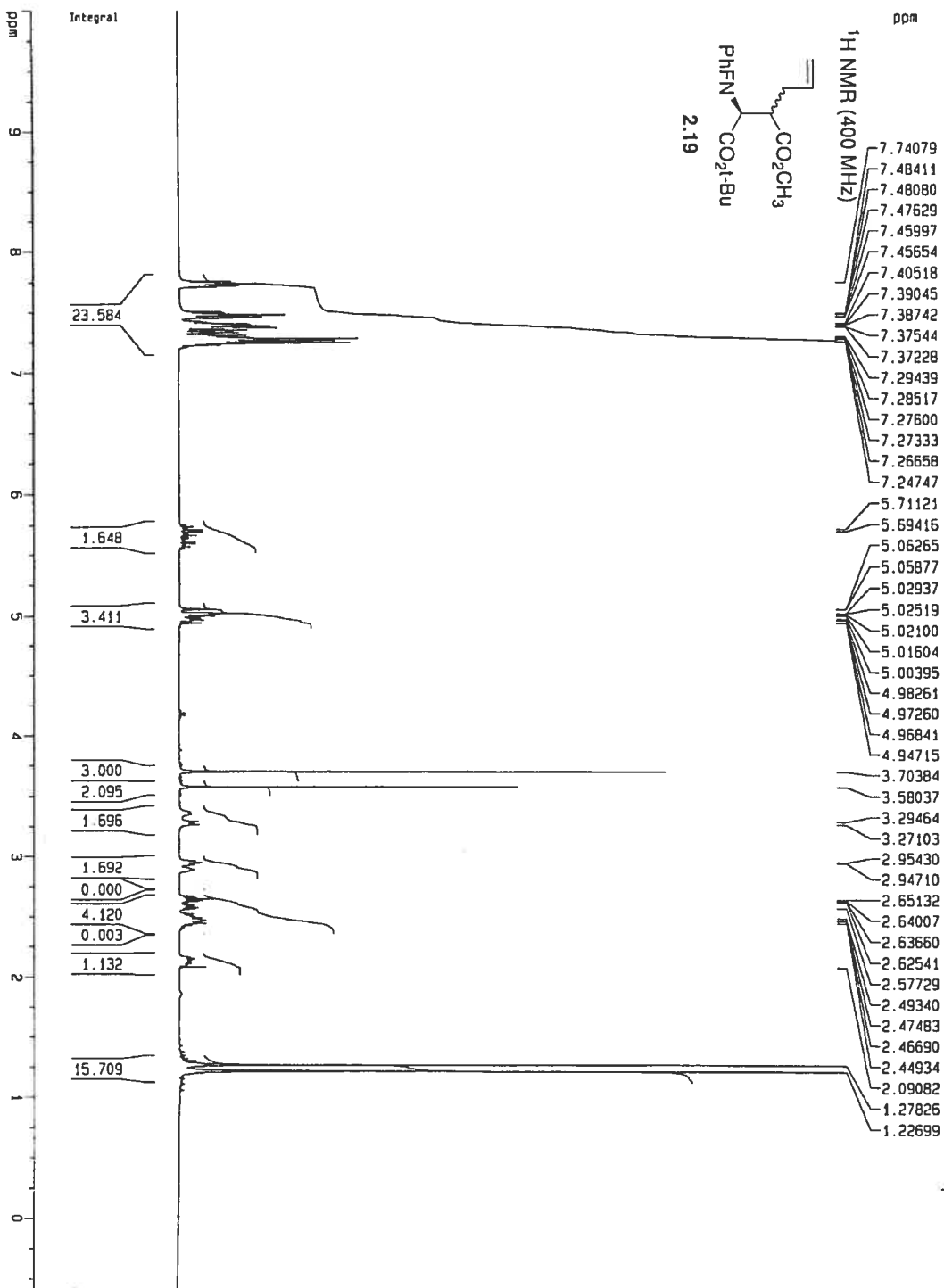

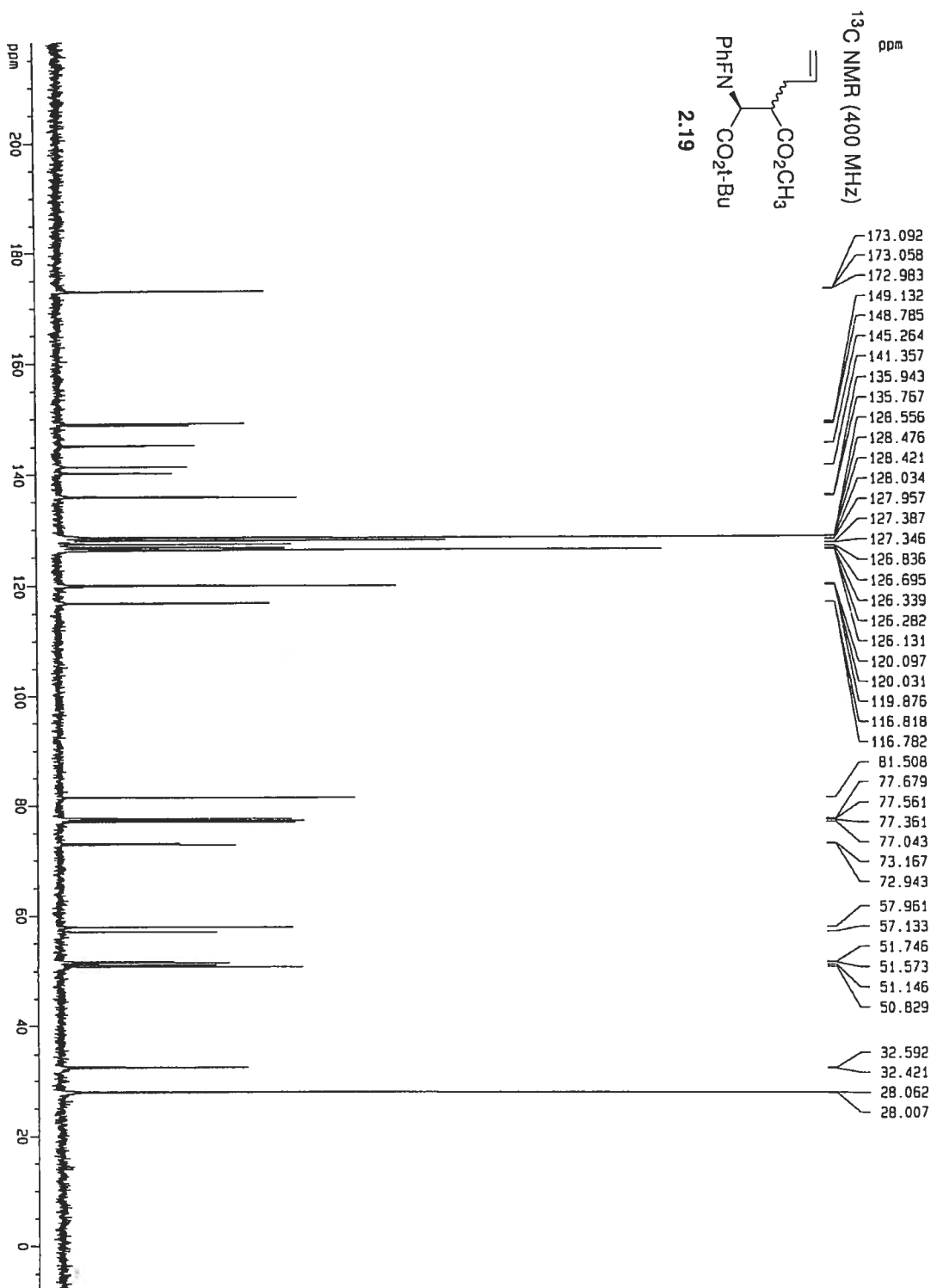

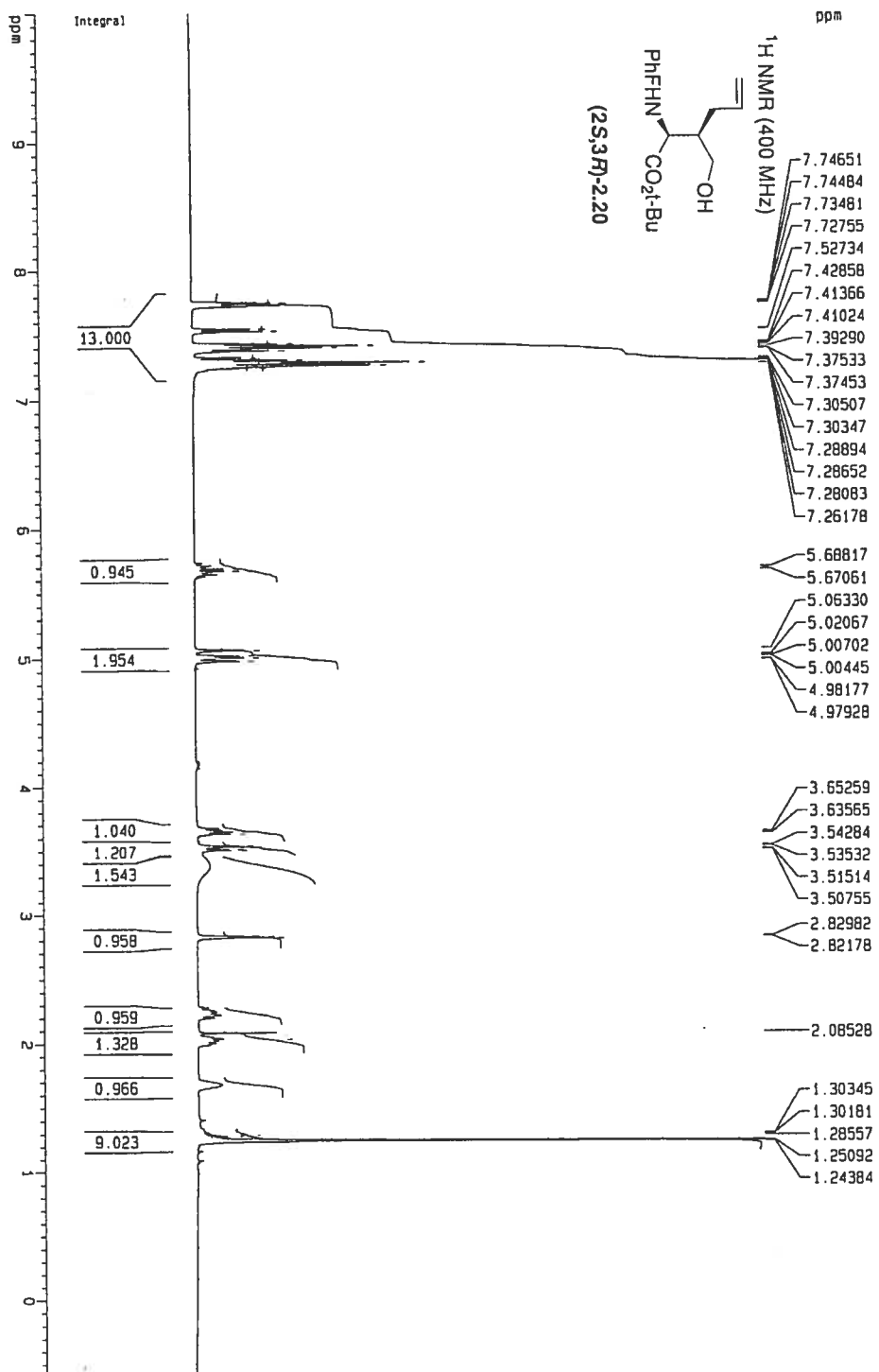

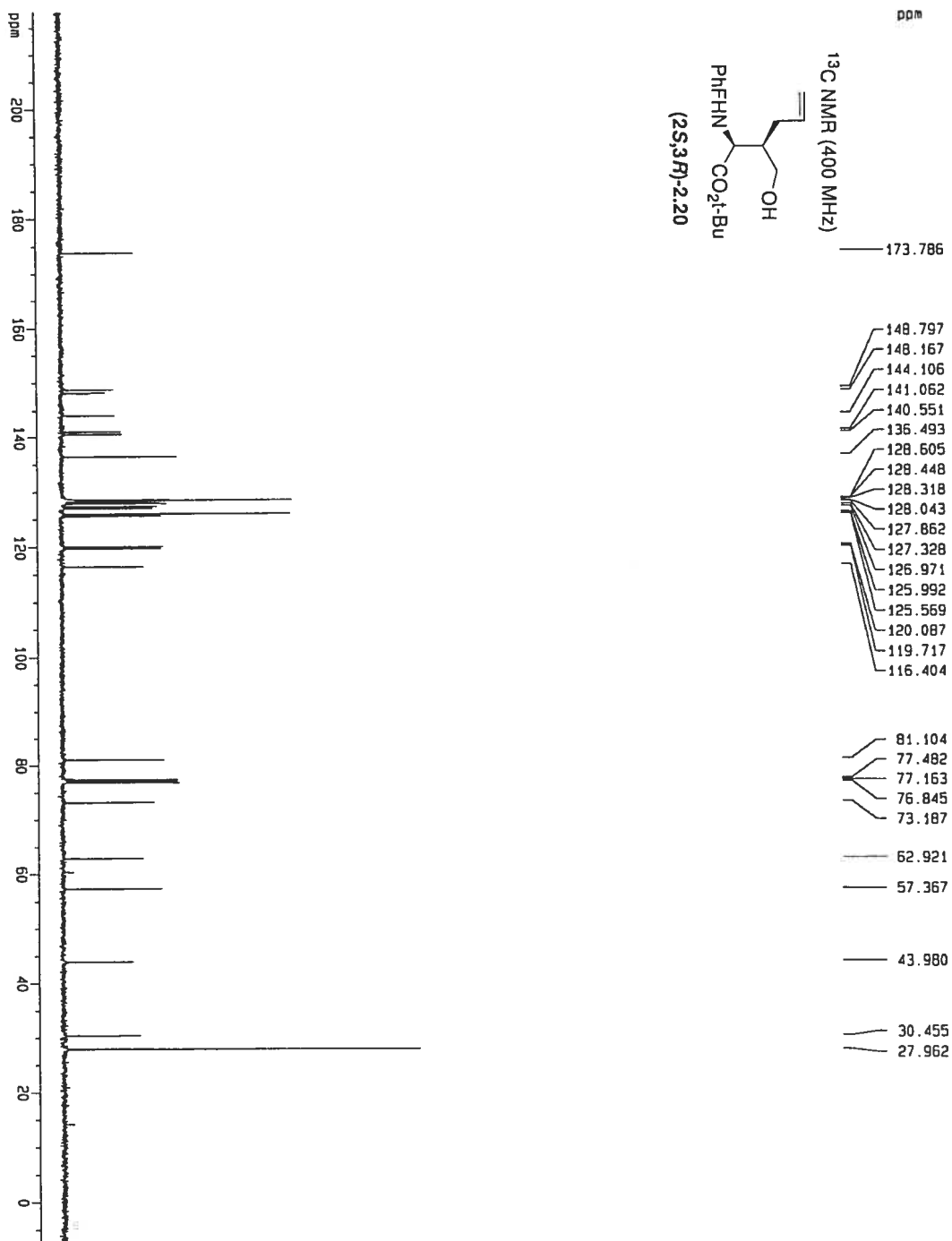



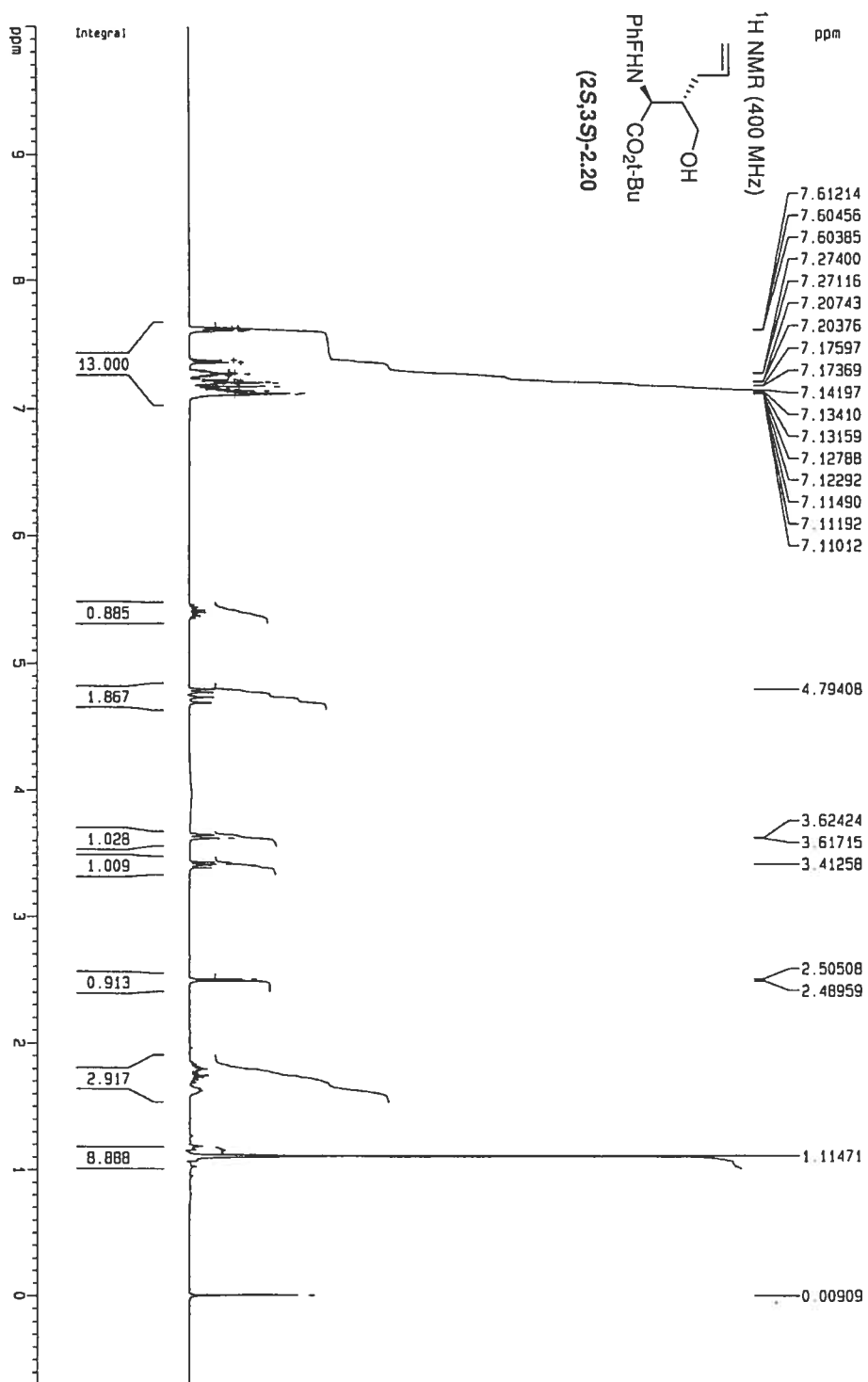

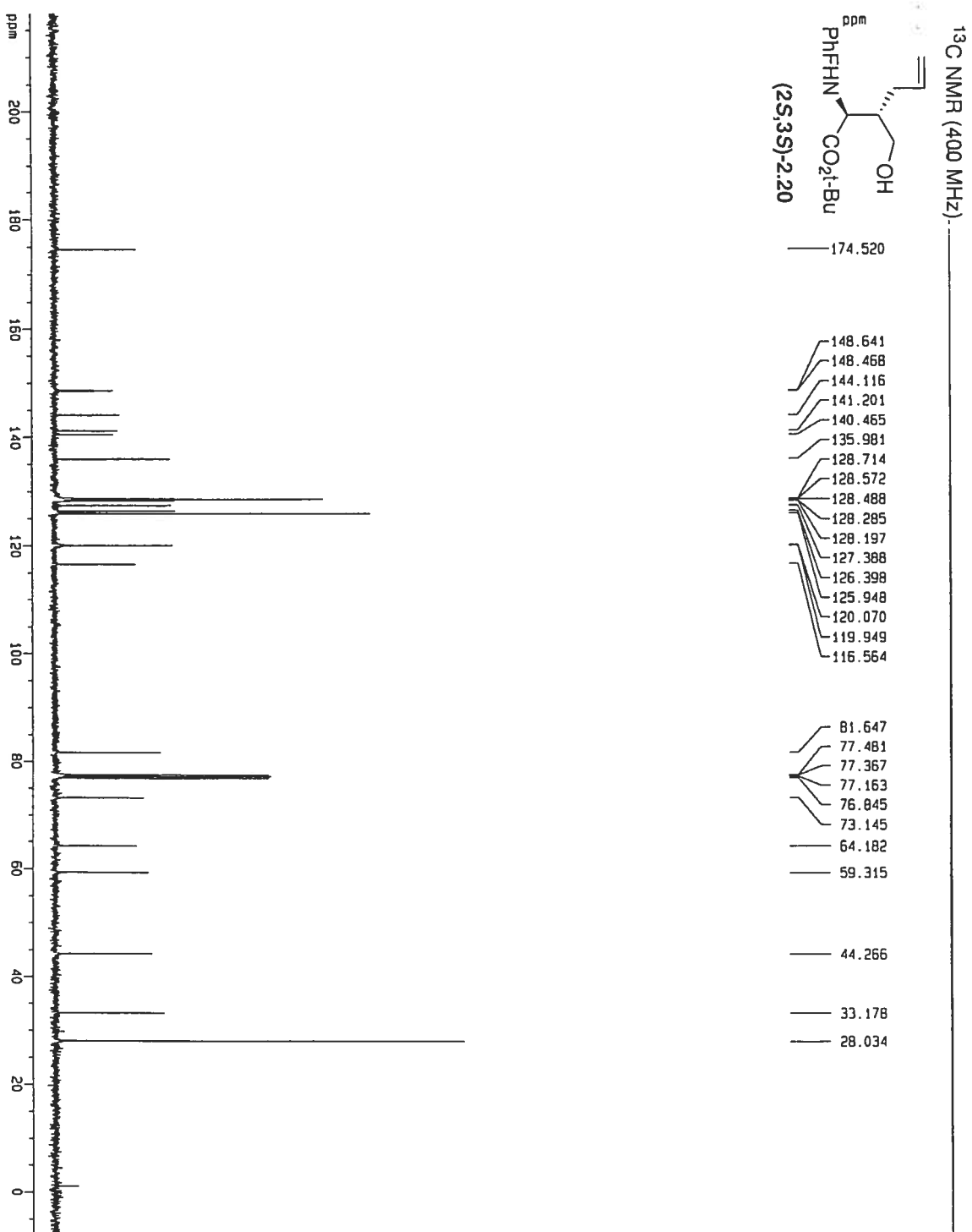

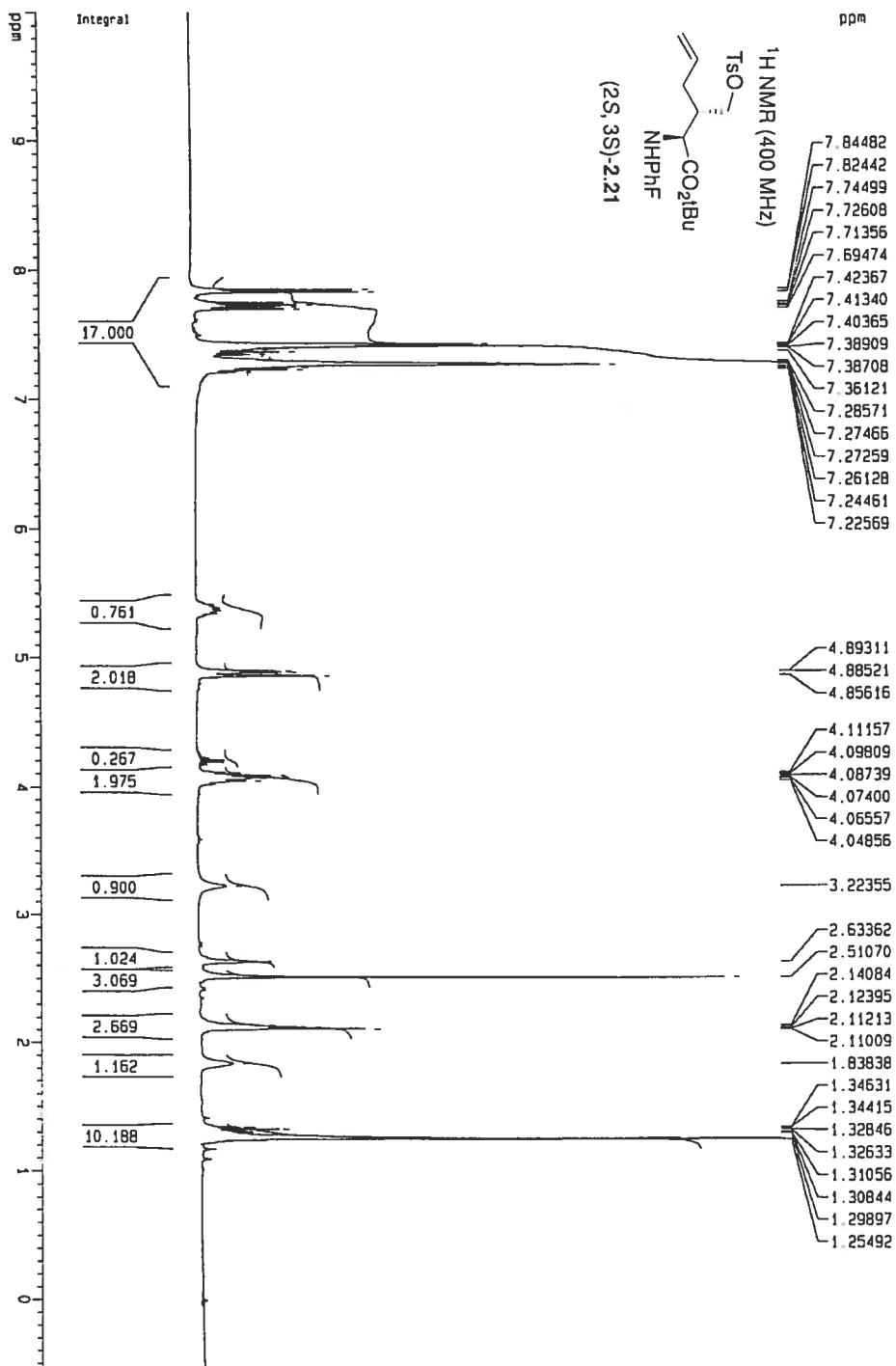

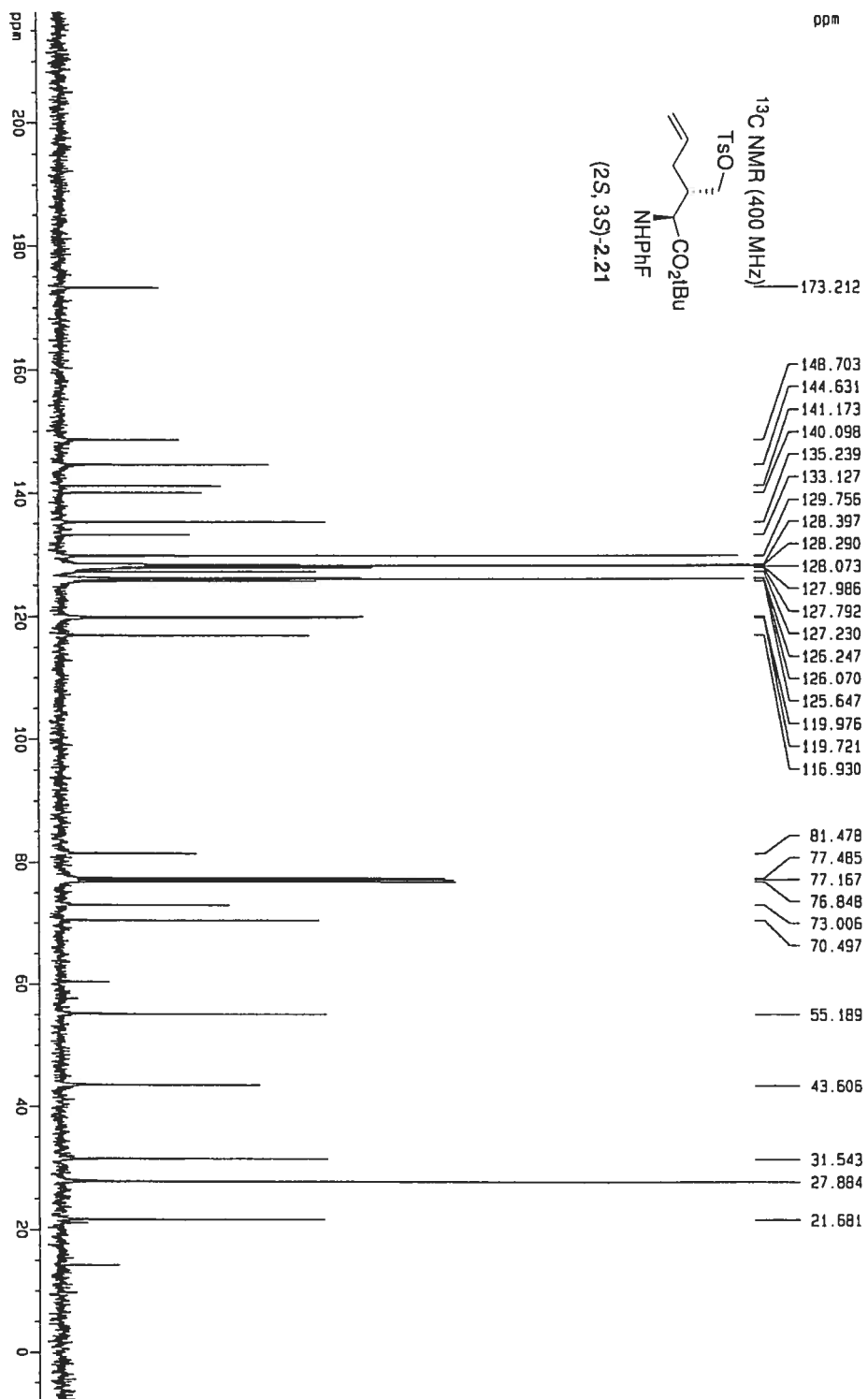

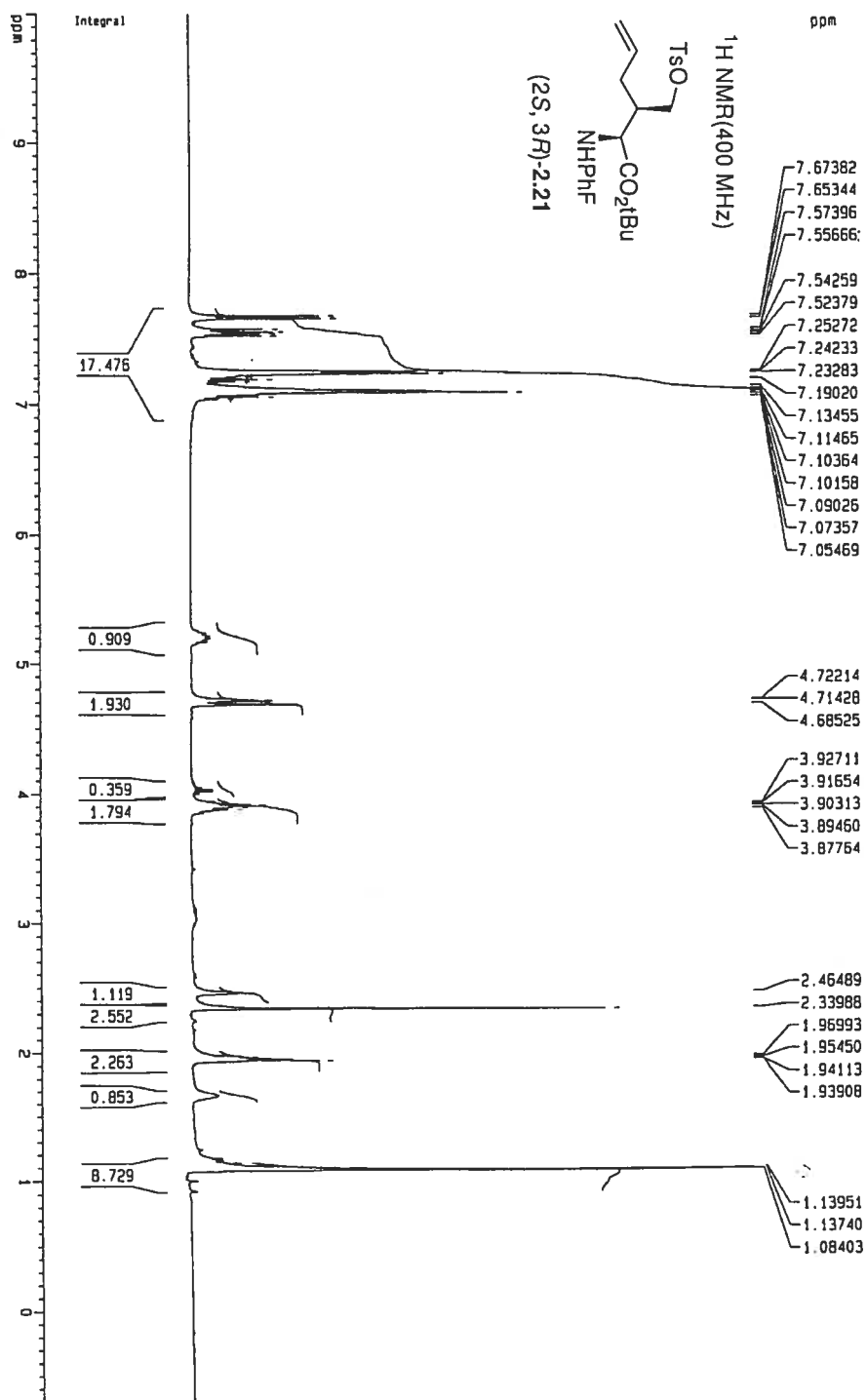

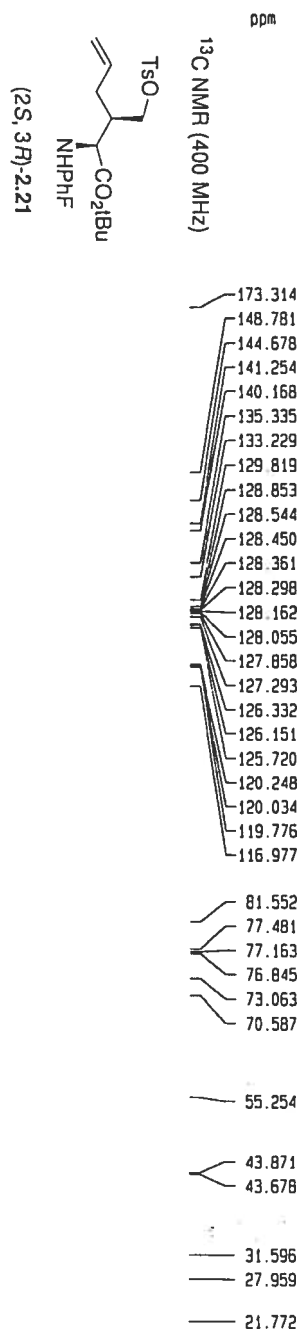

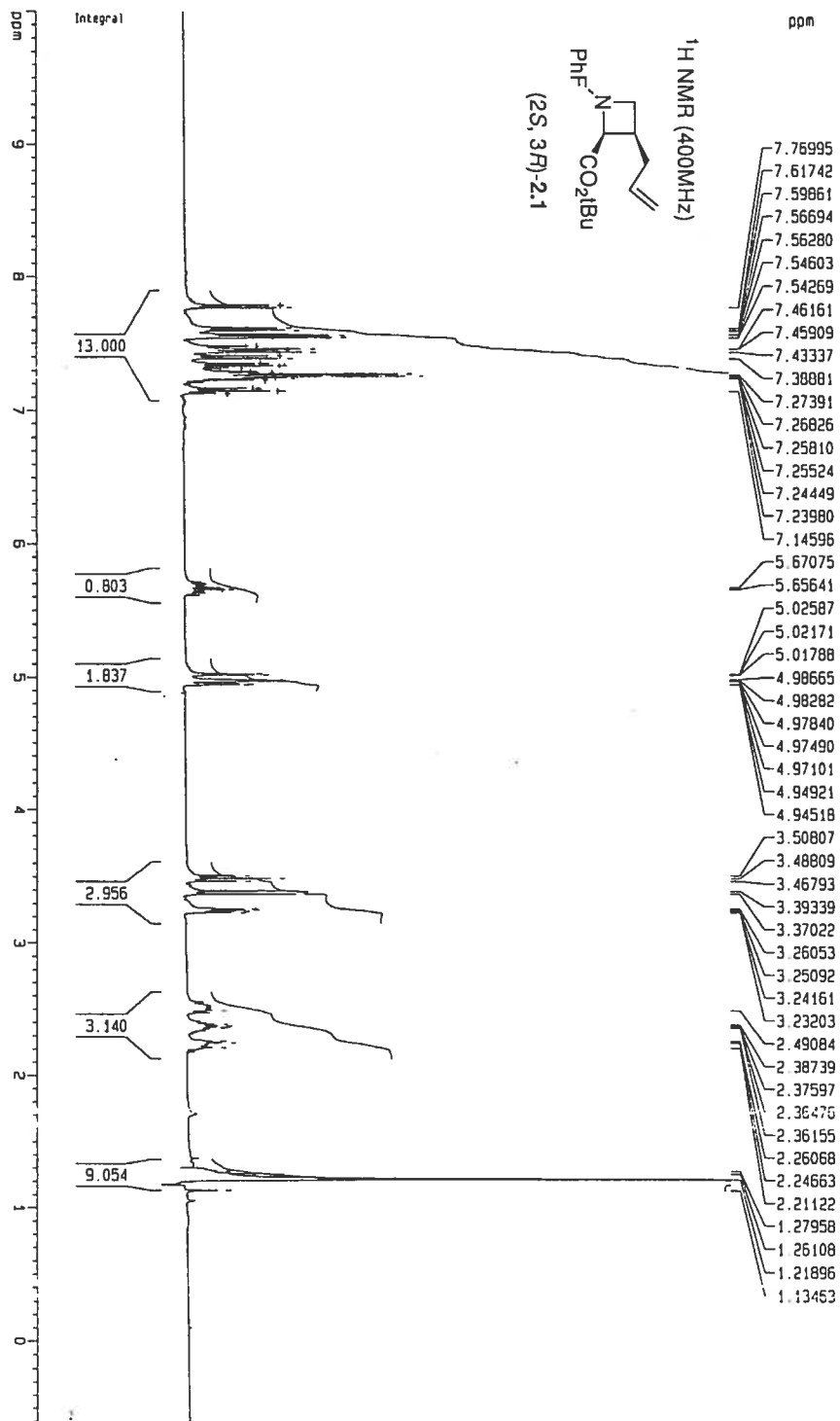

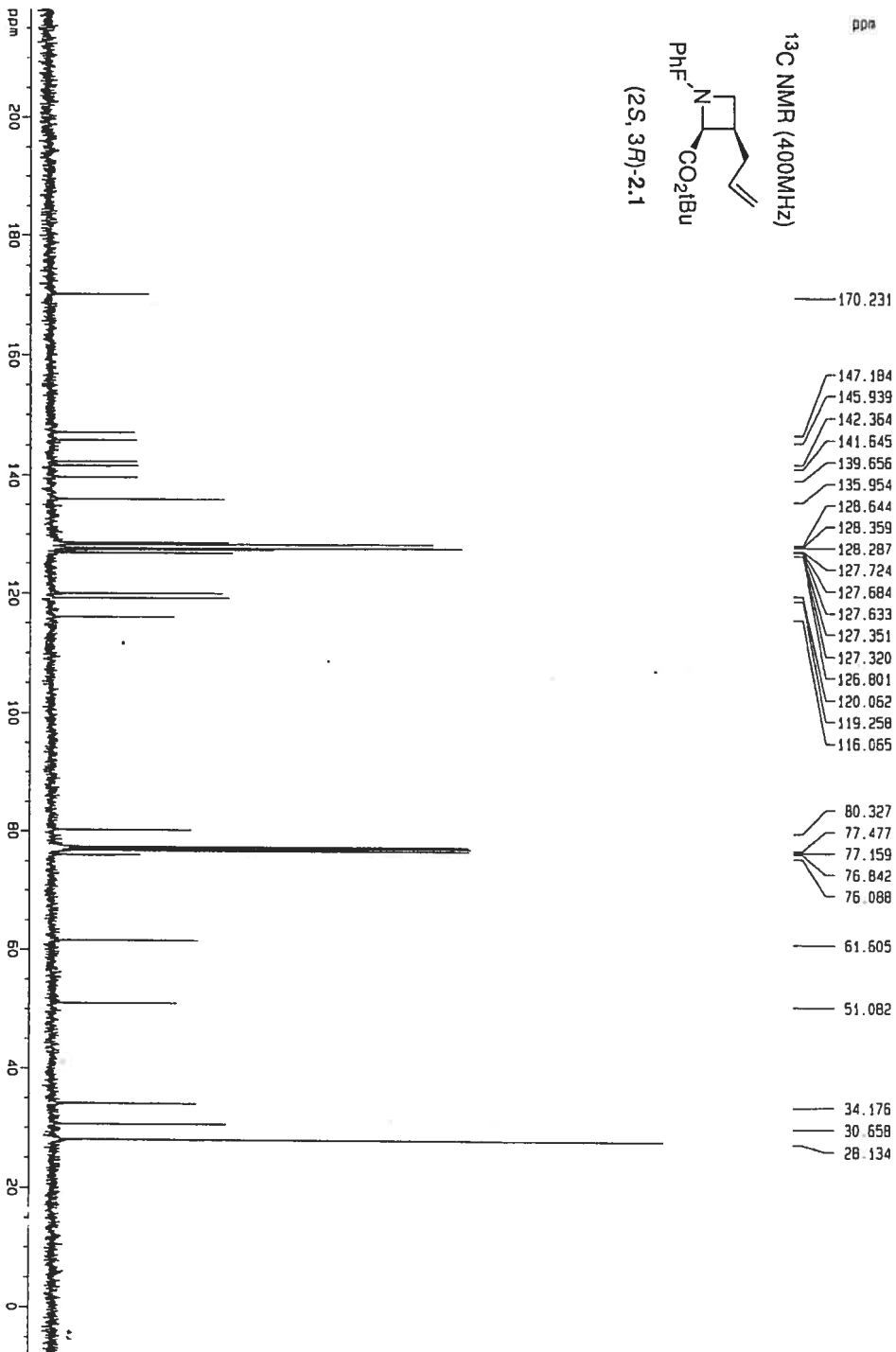



NOESY

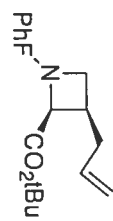

(2*S*, 3*R*)-2.1

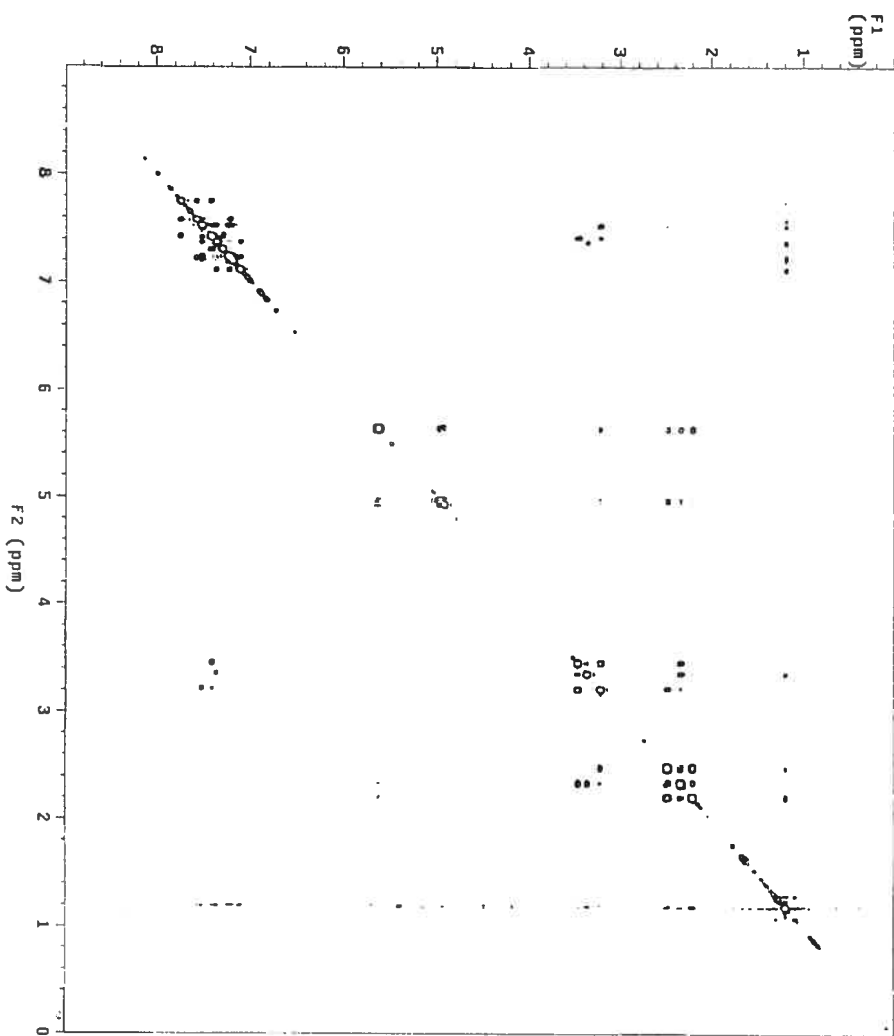
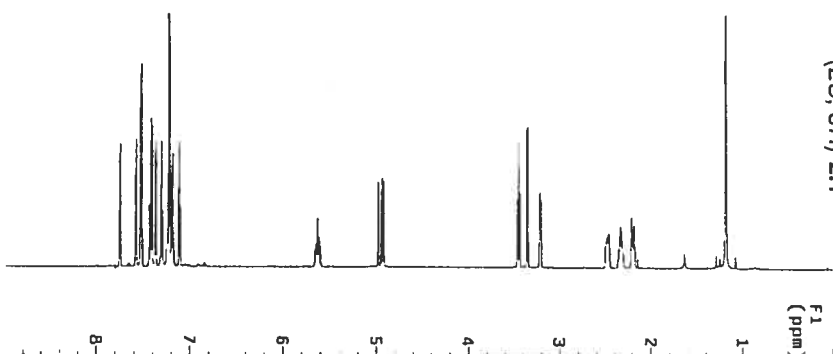

NOESY 1sec.

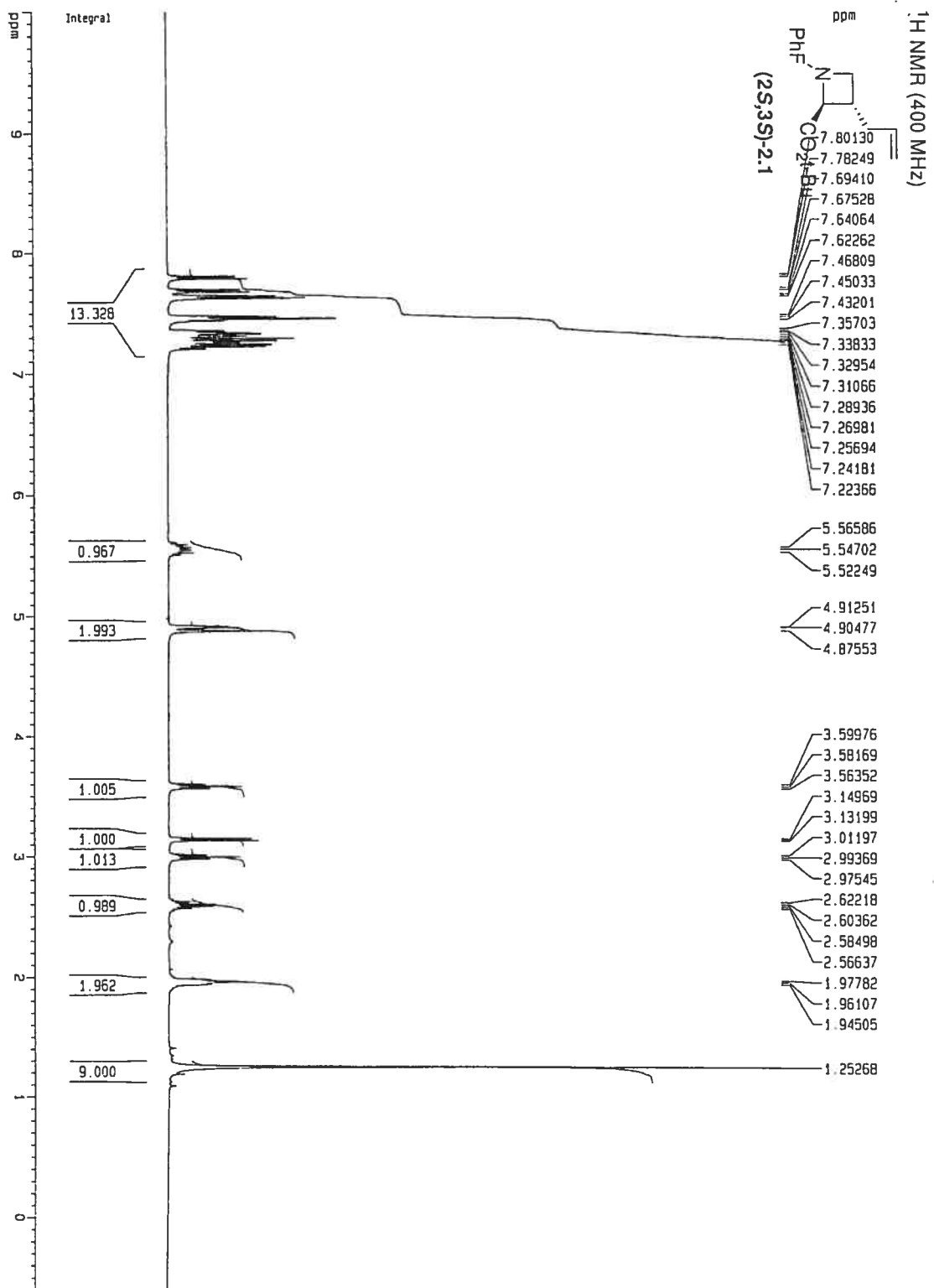

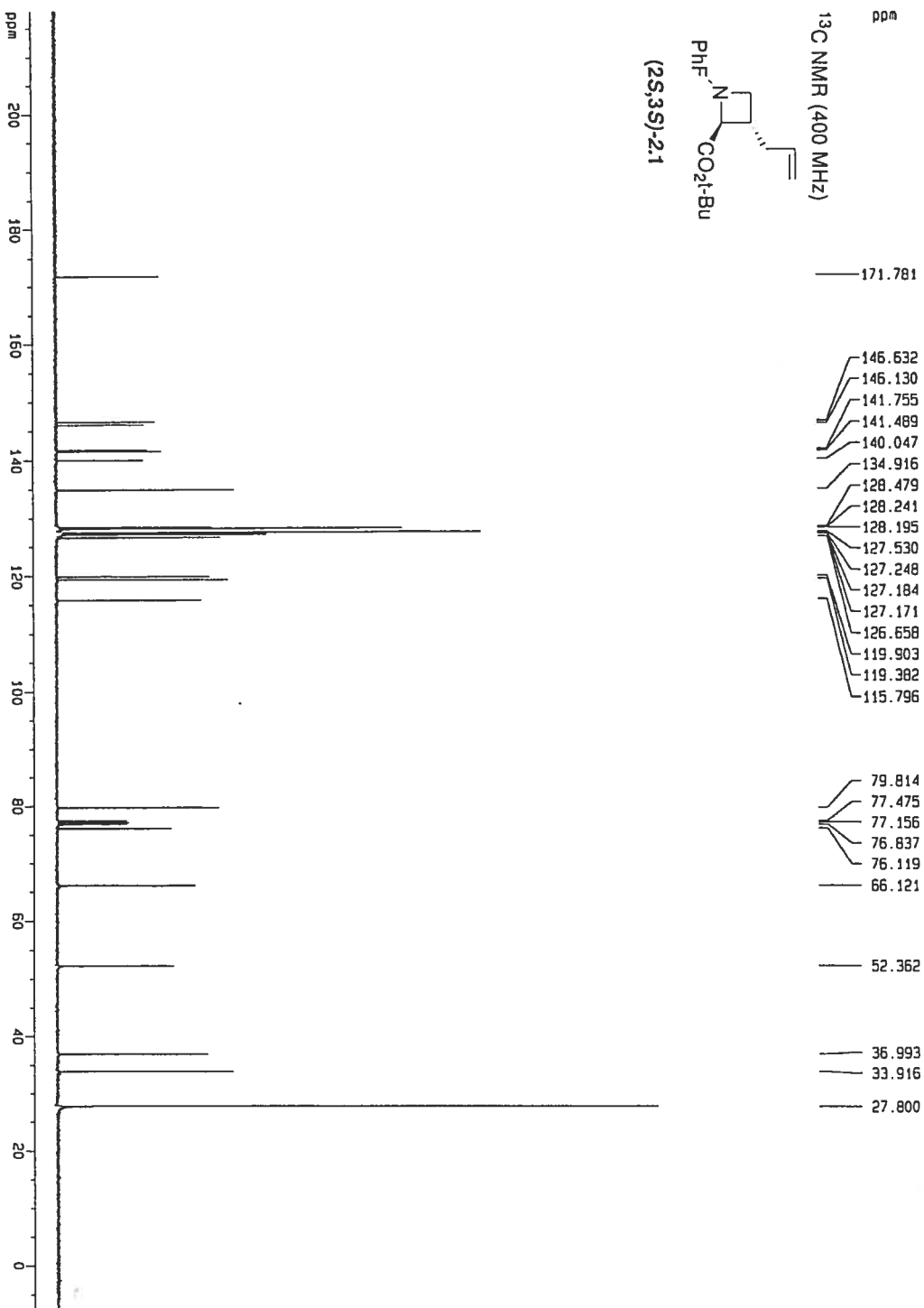

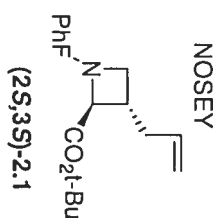
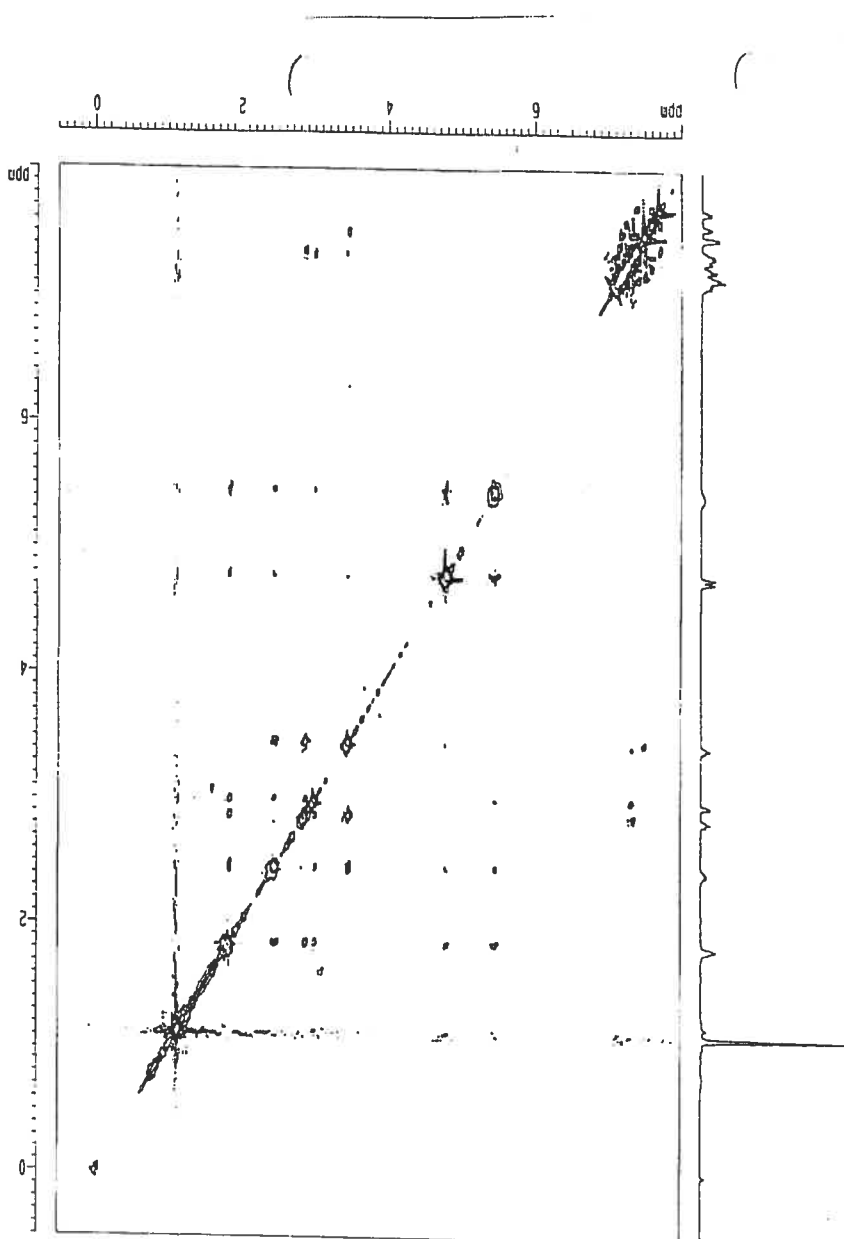

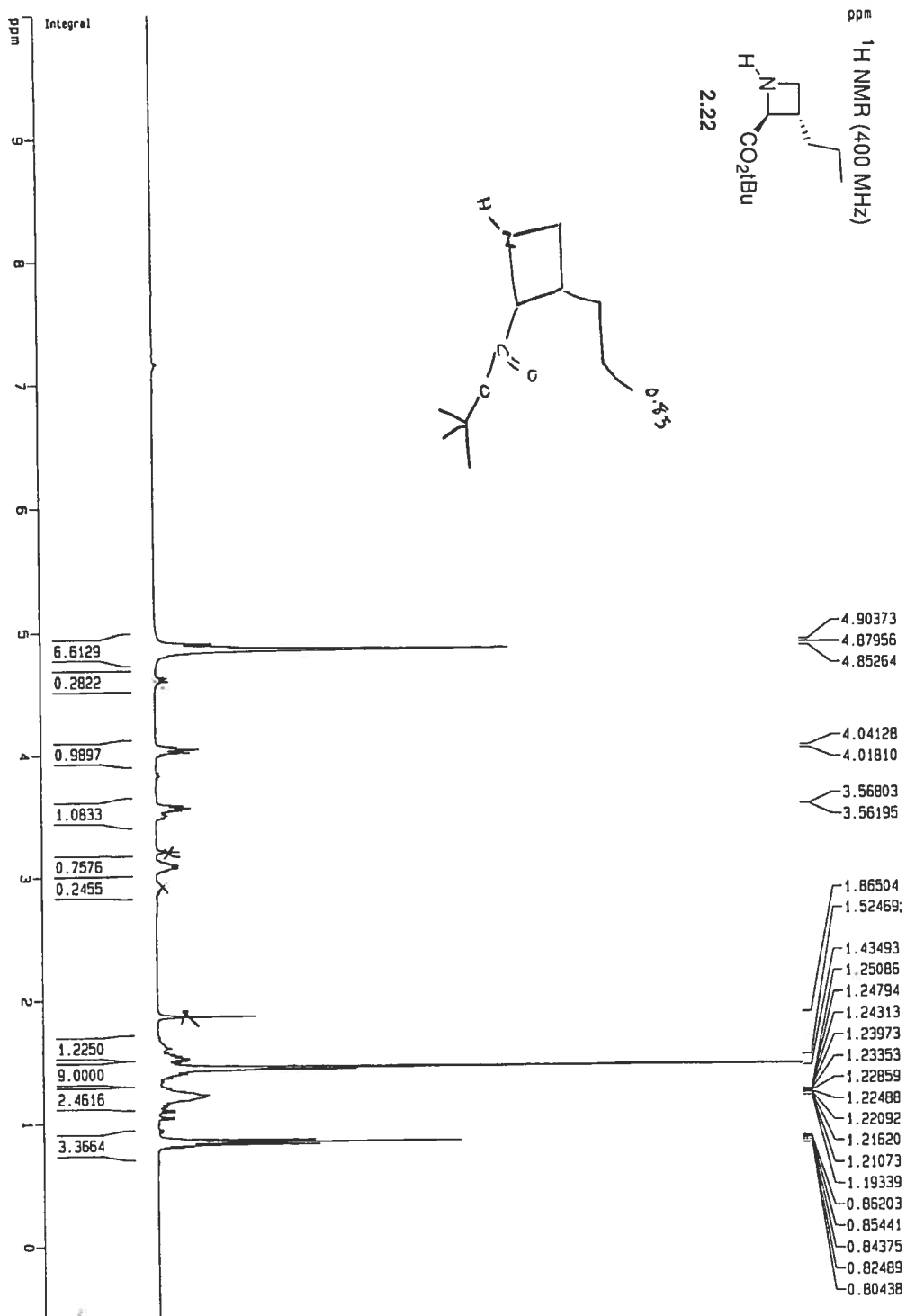

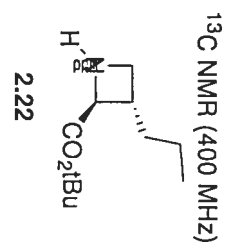

166.704

84.627

77.479

77.162

76.844

62.905

48.742

37.170

35.101

28.010

19.628

13.672

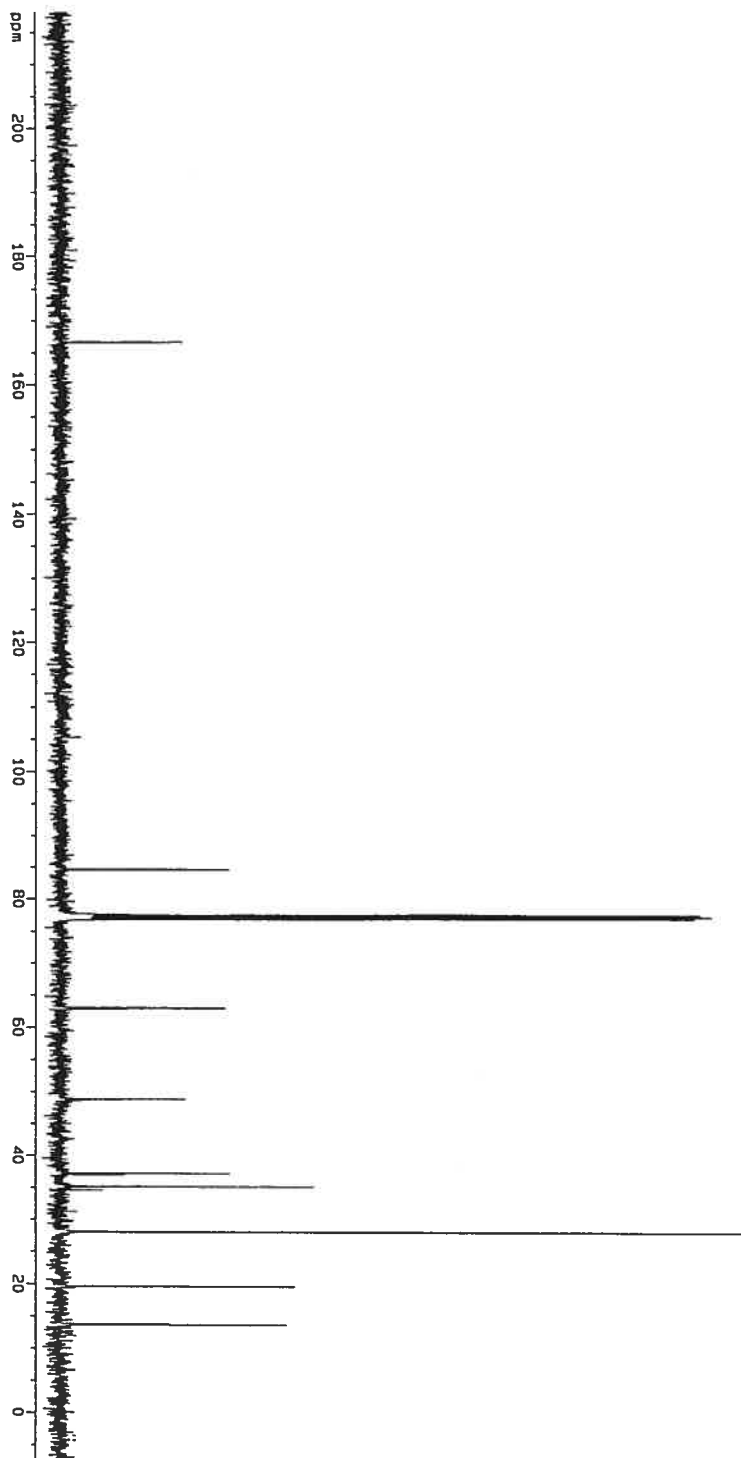

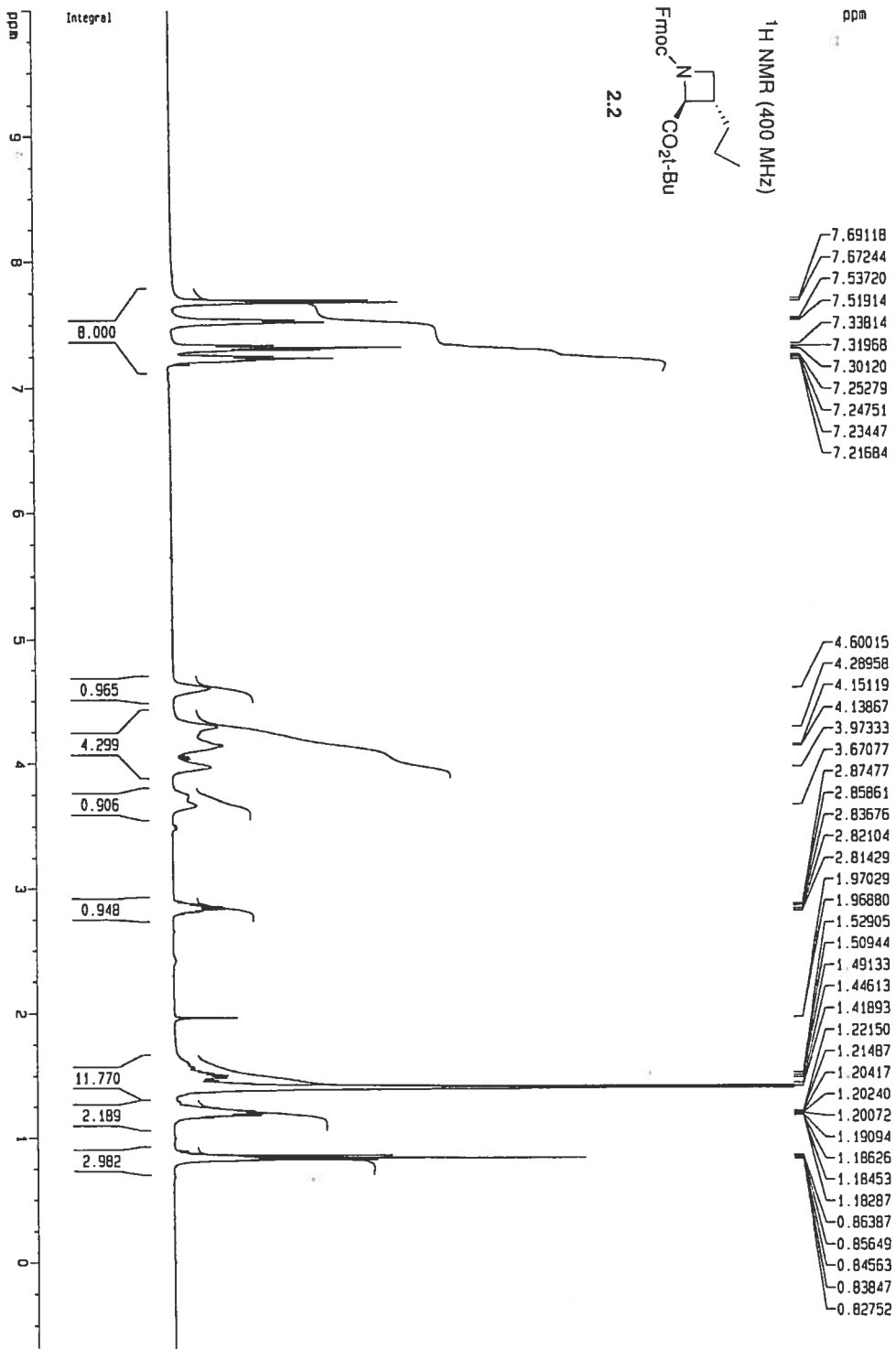

<sup>13</sup>C NMR (400 MHz)

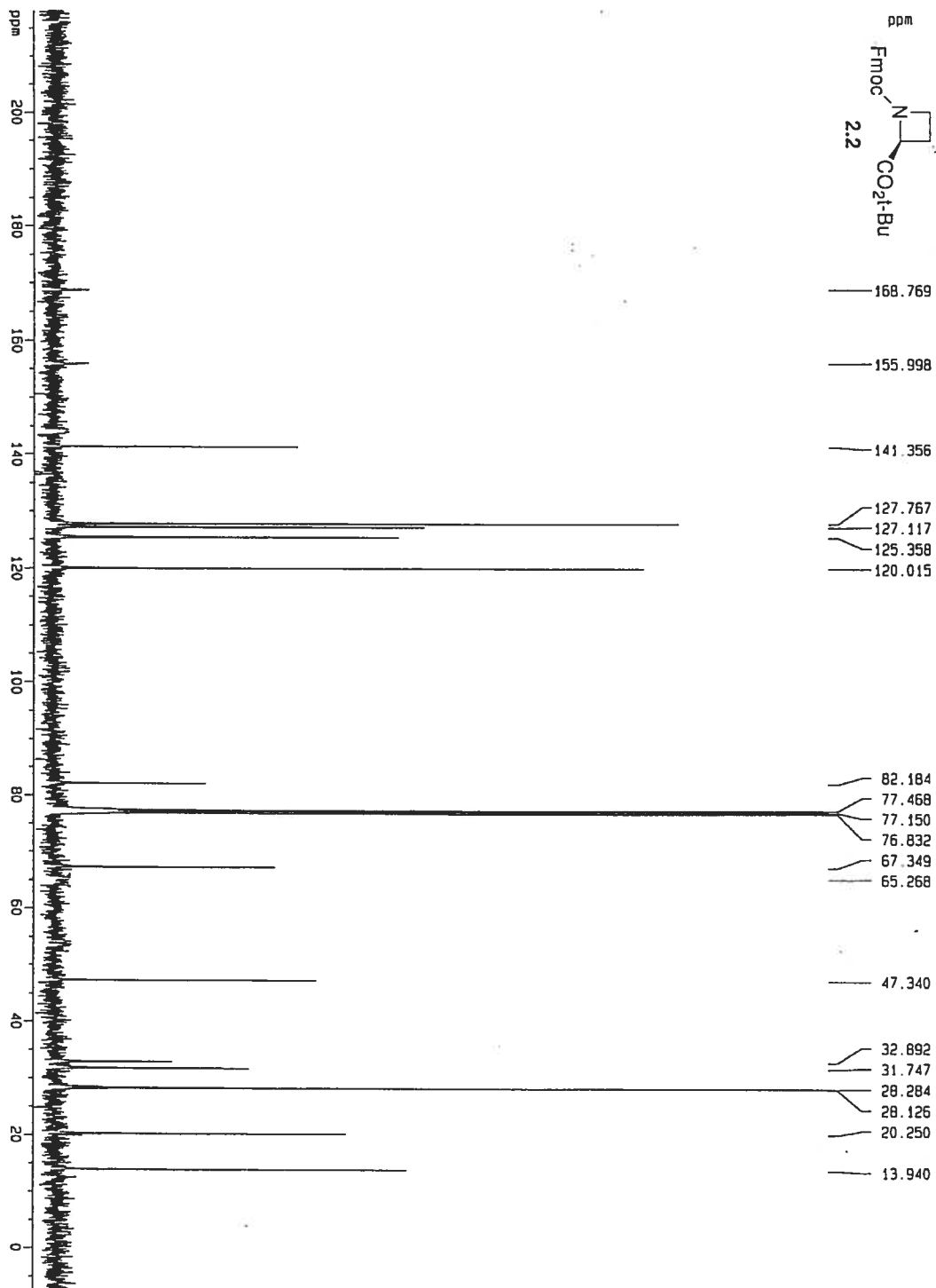
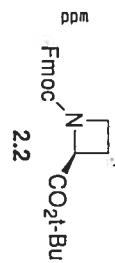



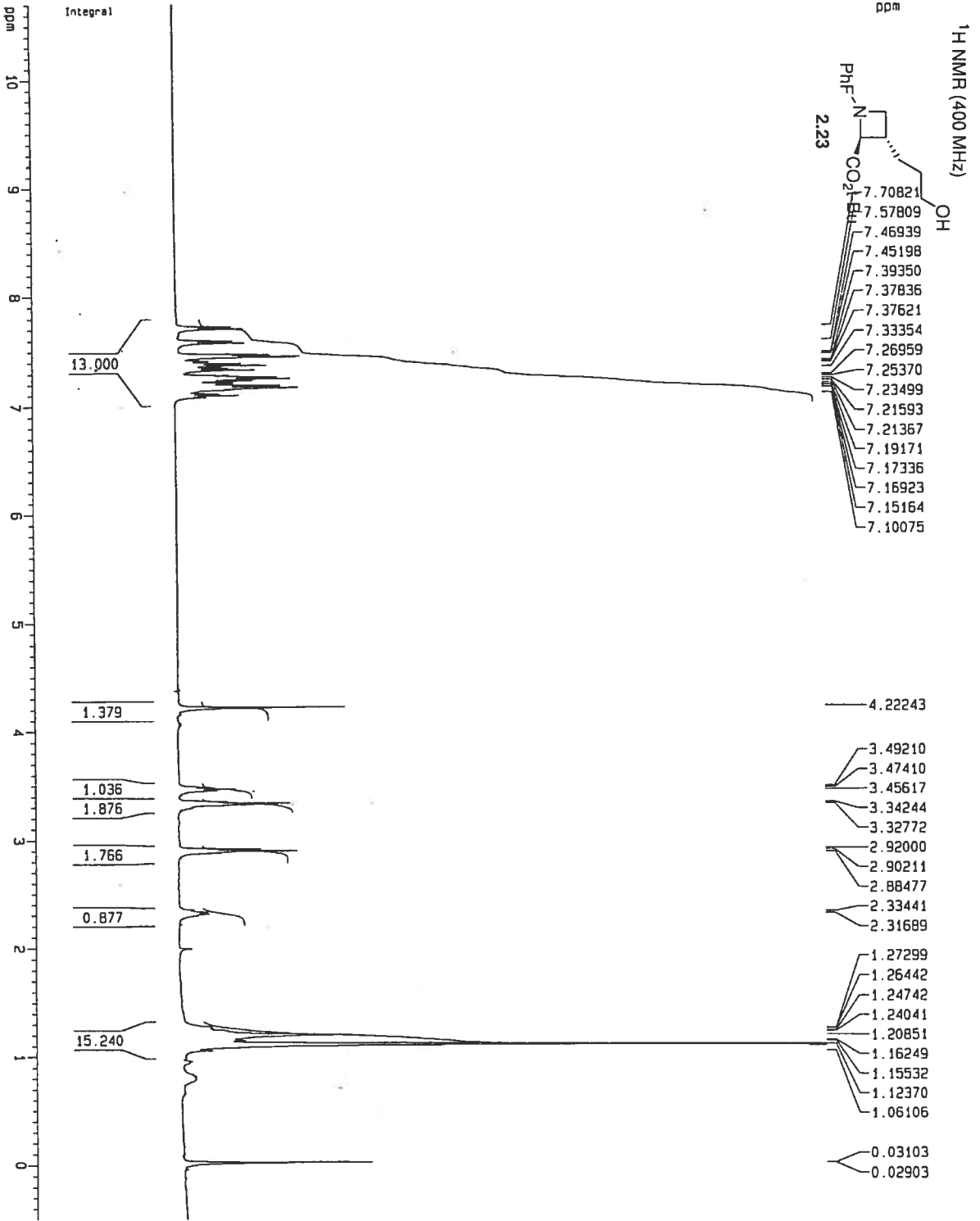

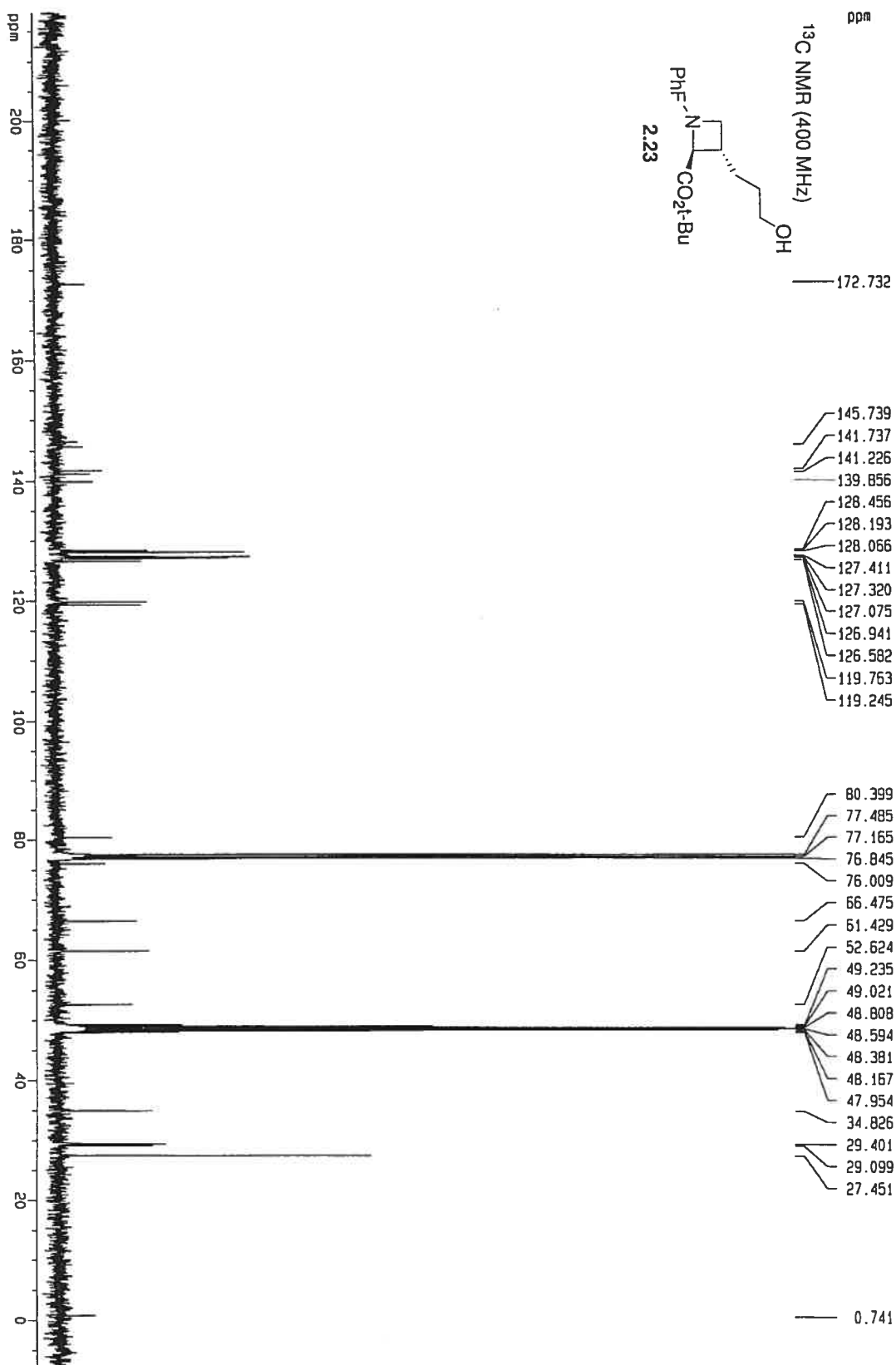

Z. Sajjadi; W. D. Lubell  
<sup>1</sup>H NMR (400 MHz)

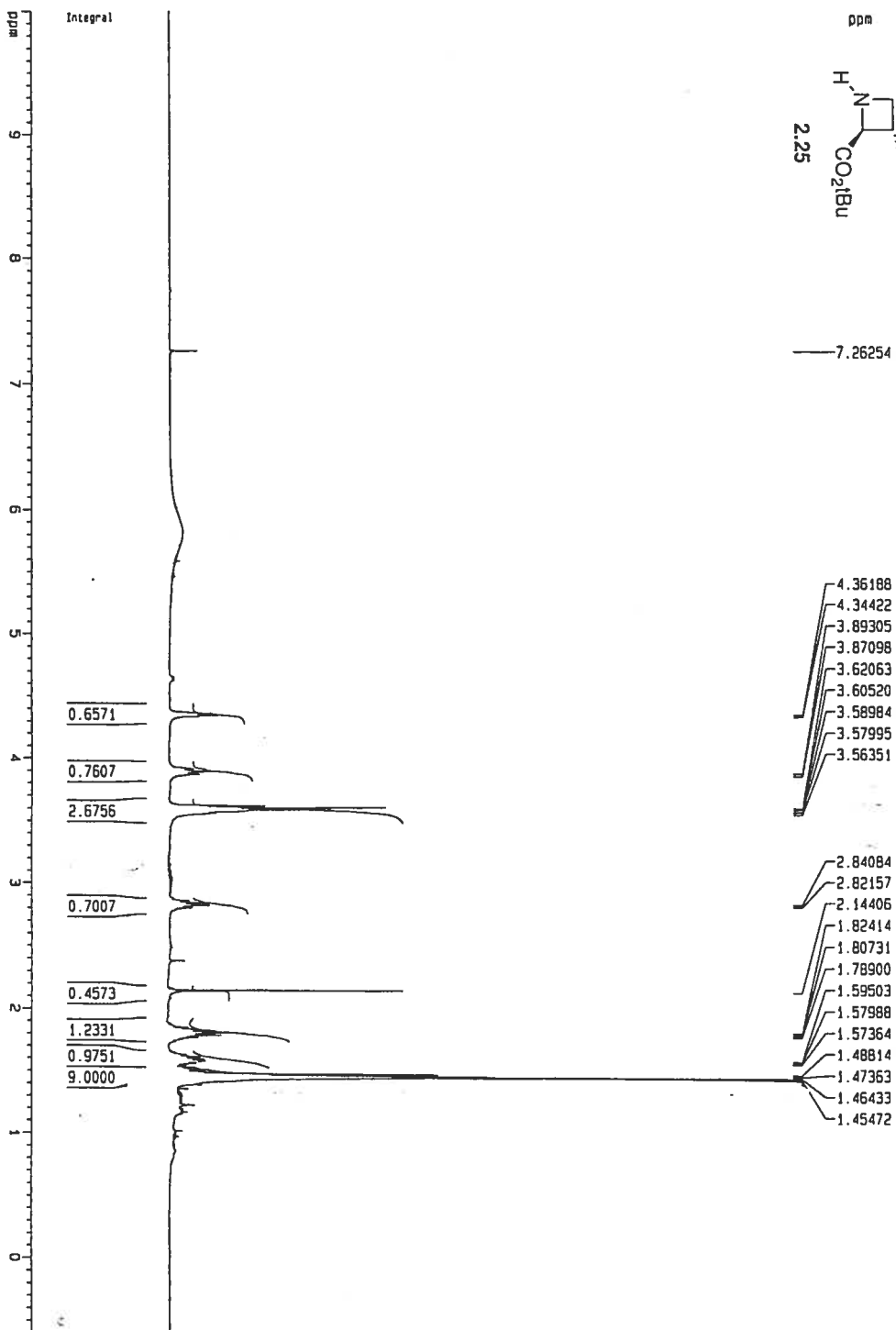
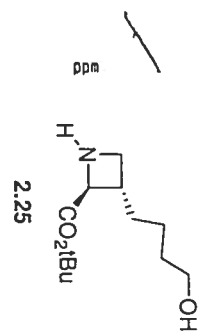

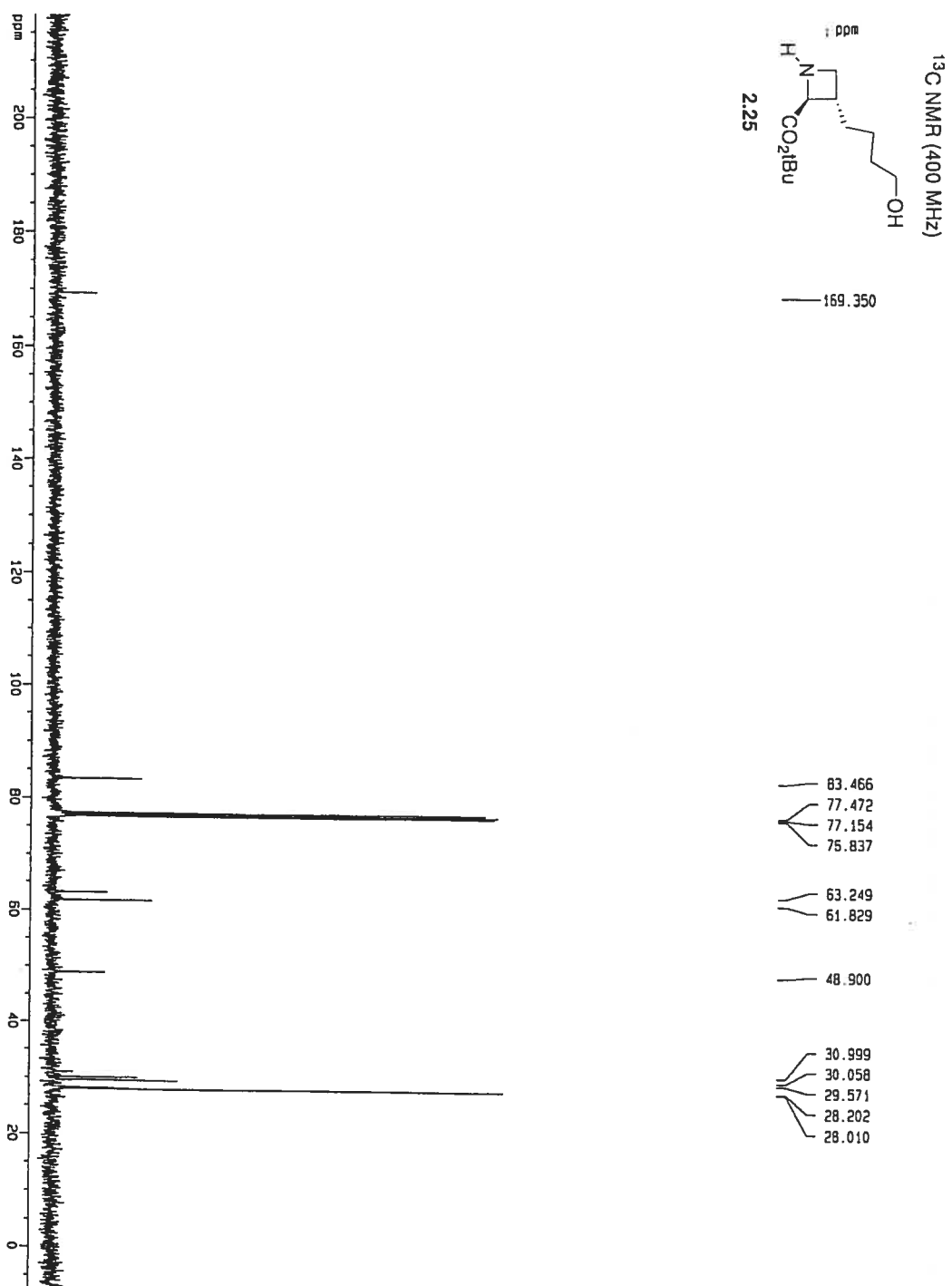

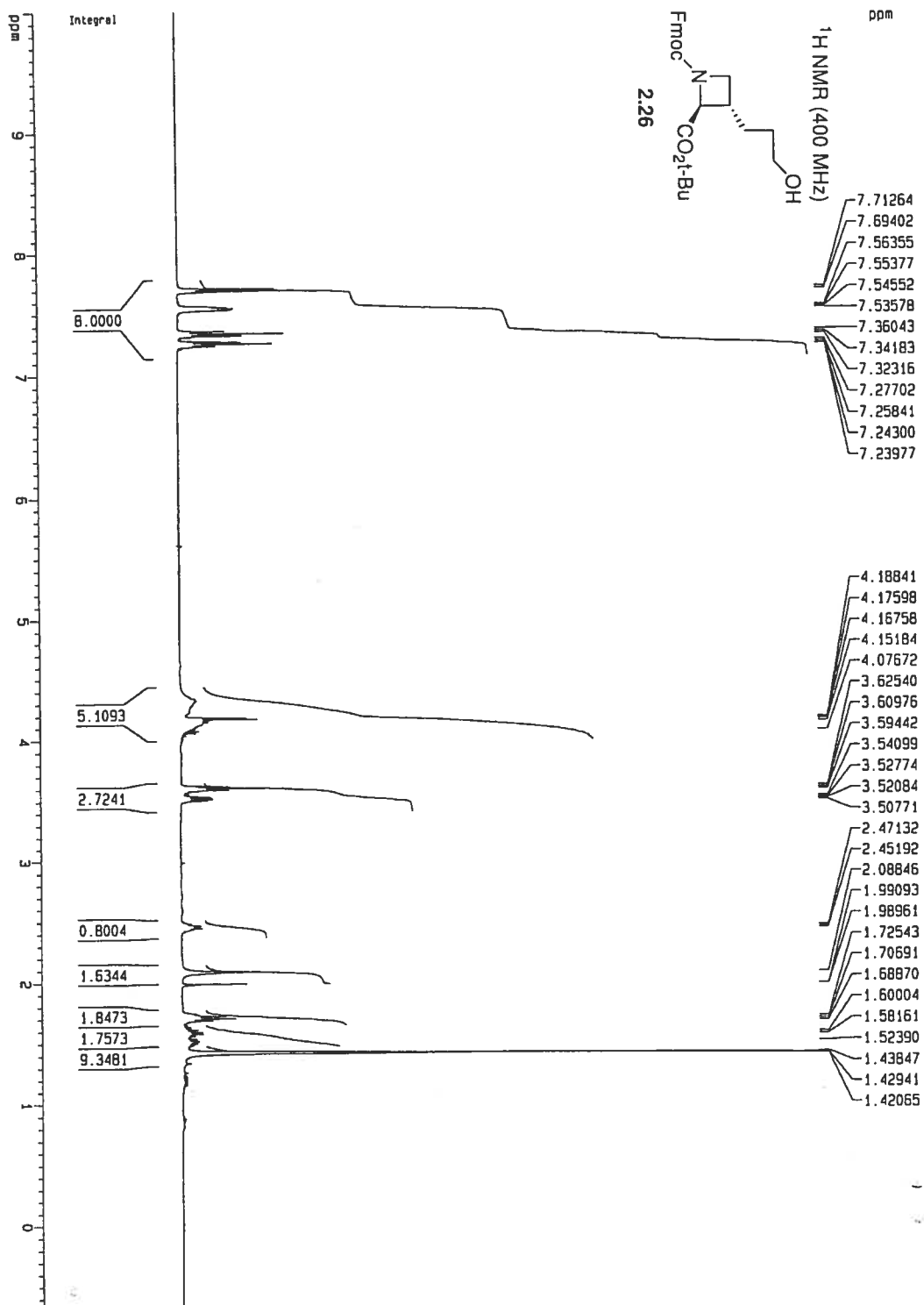

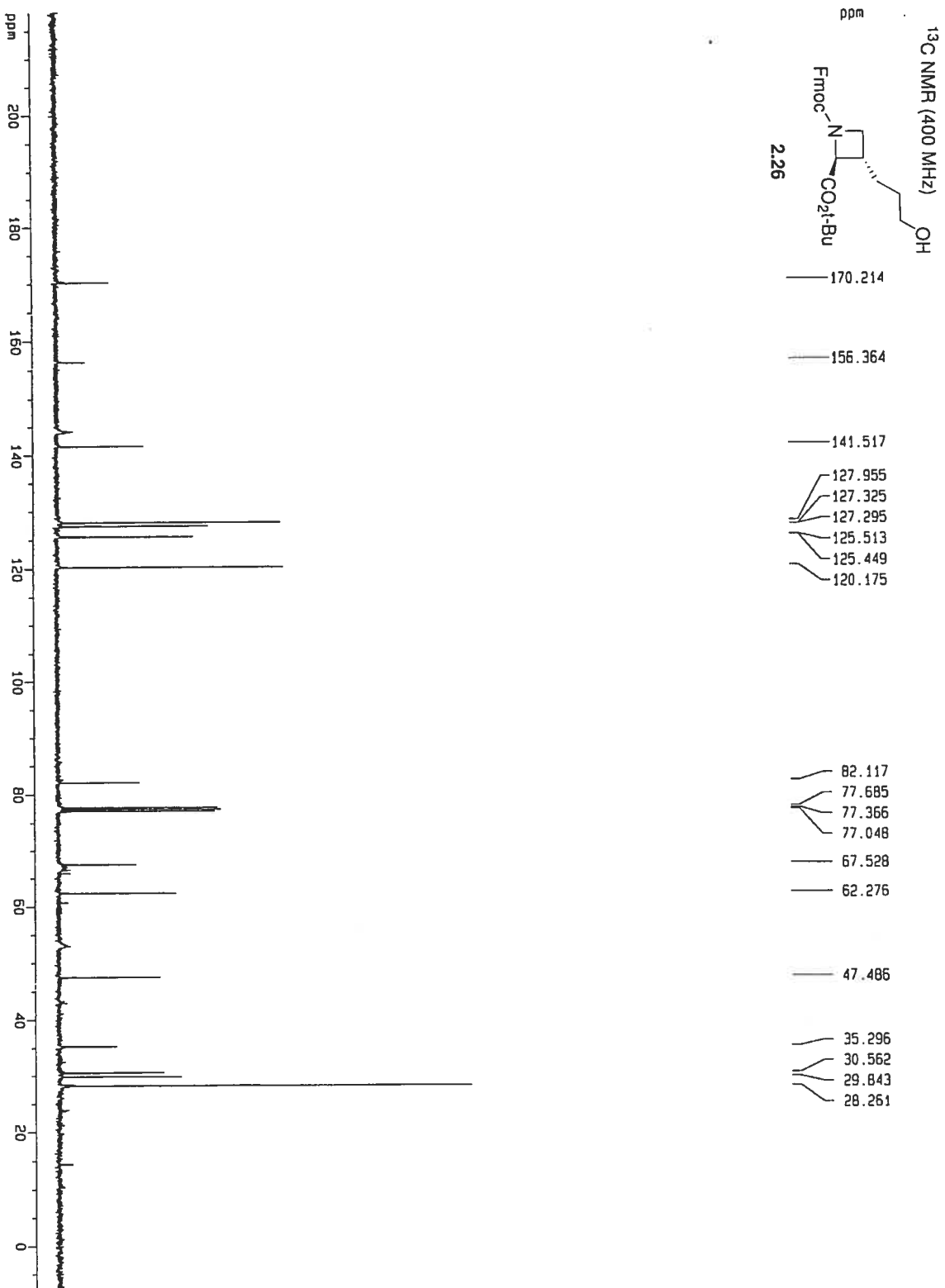

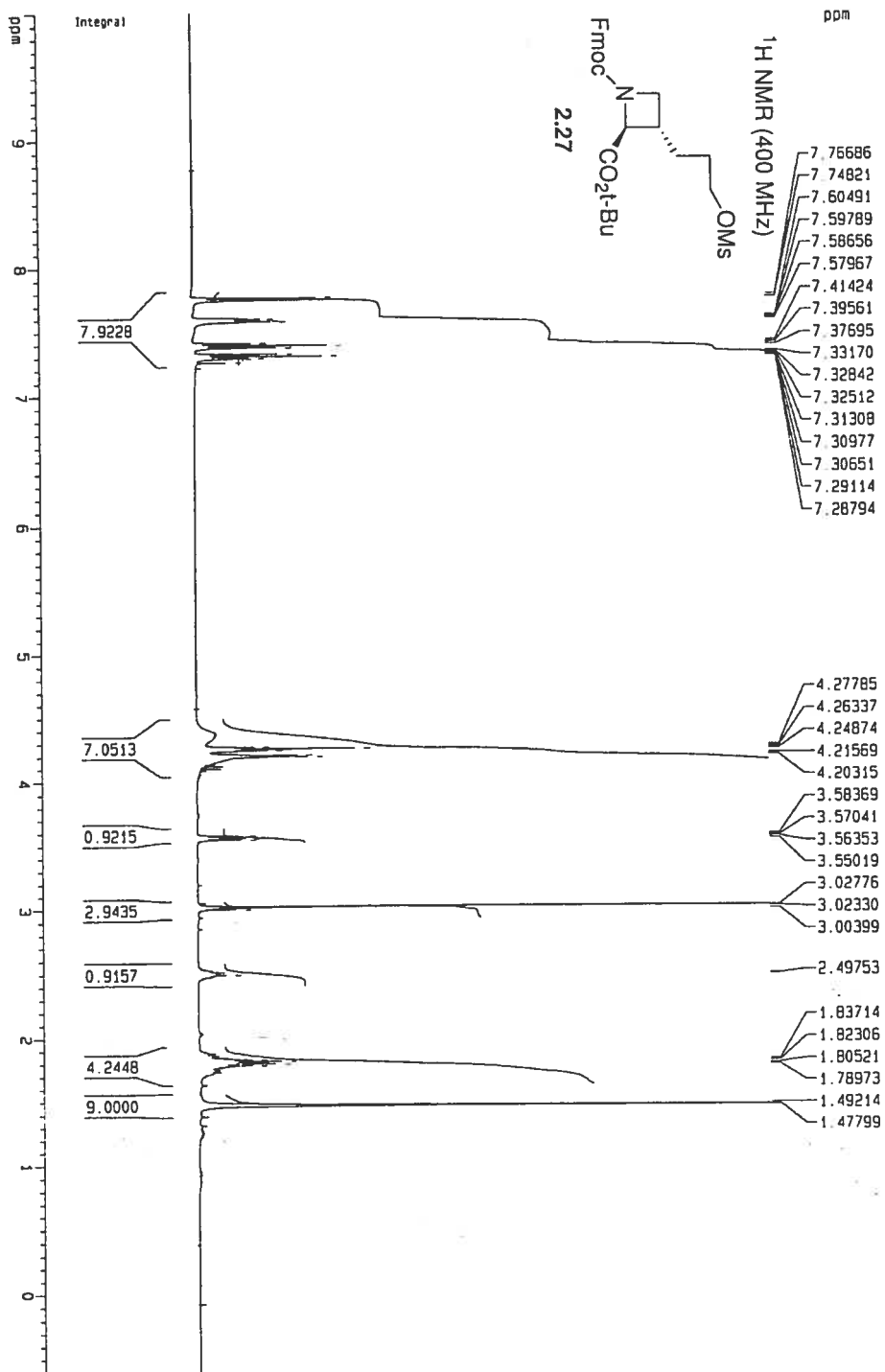

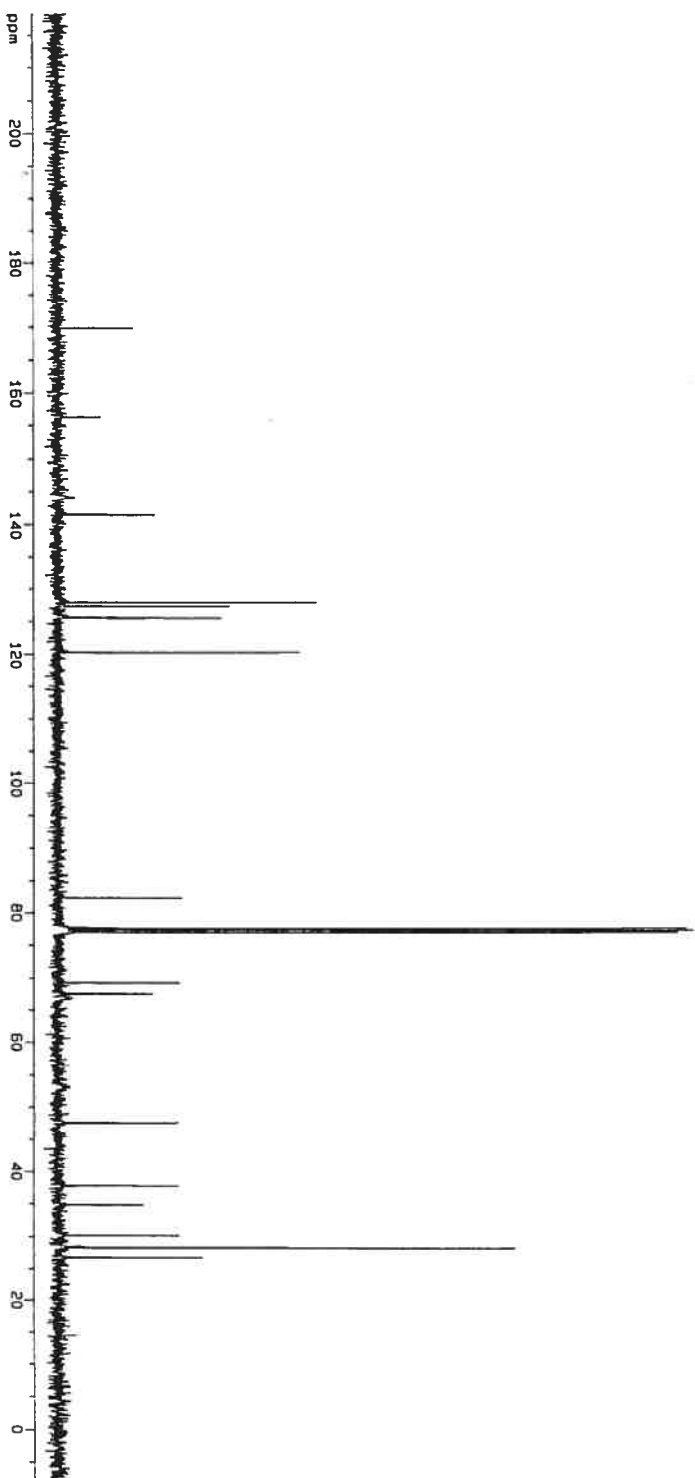
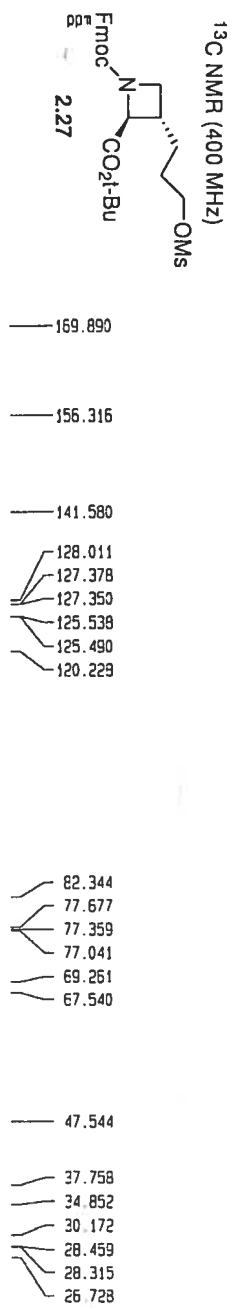



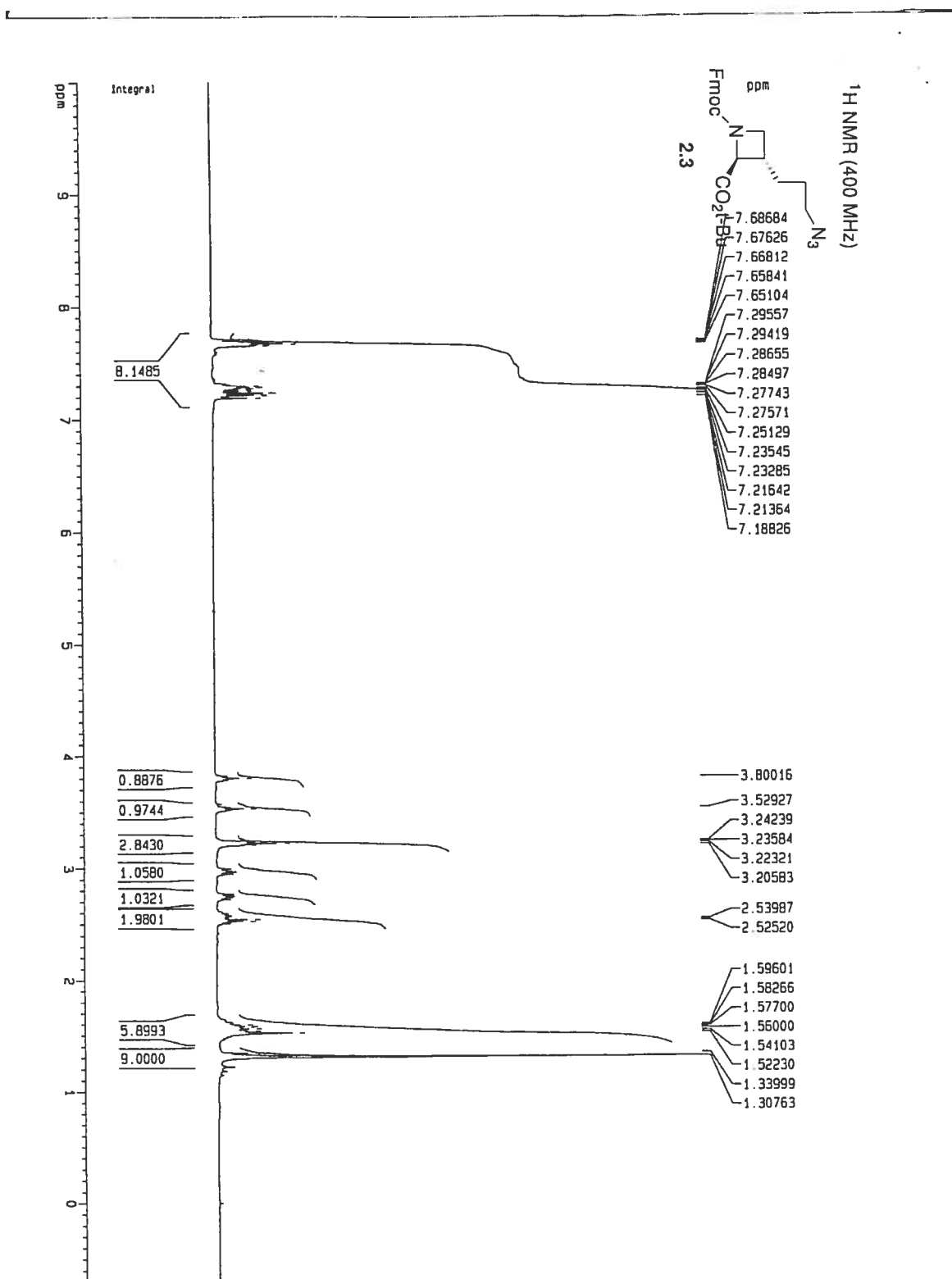

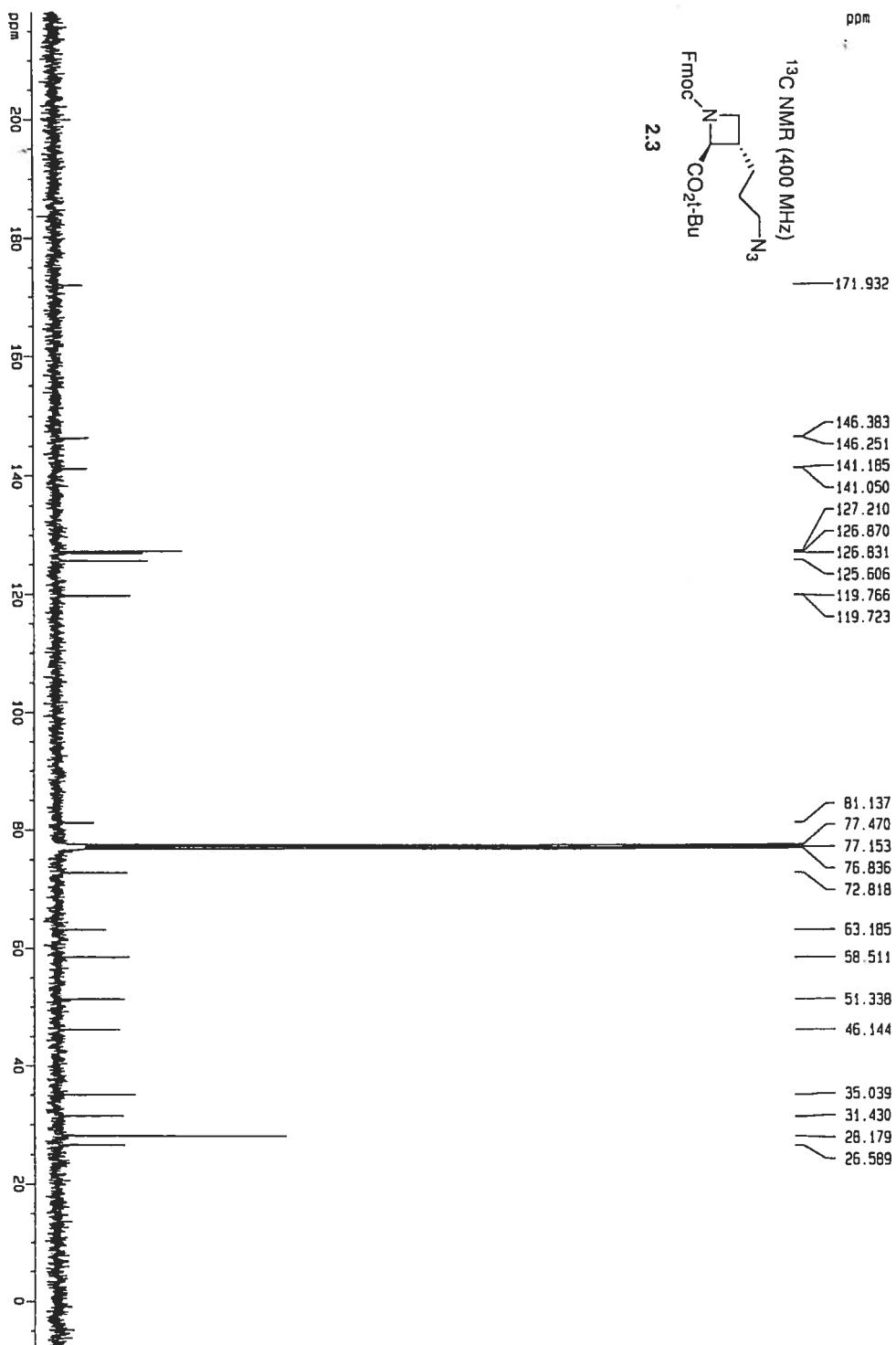

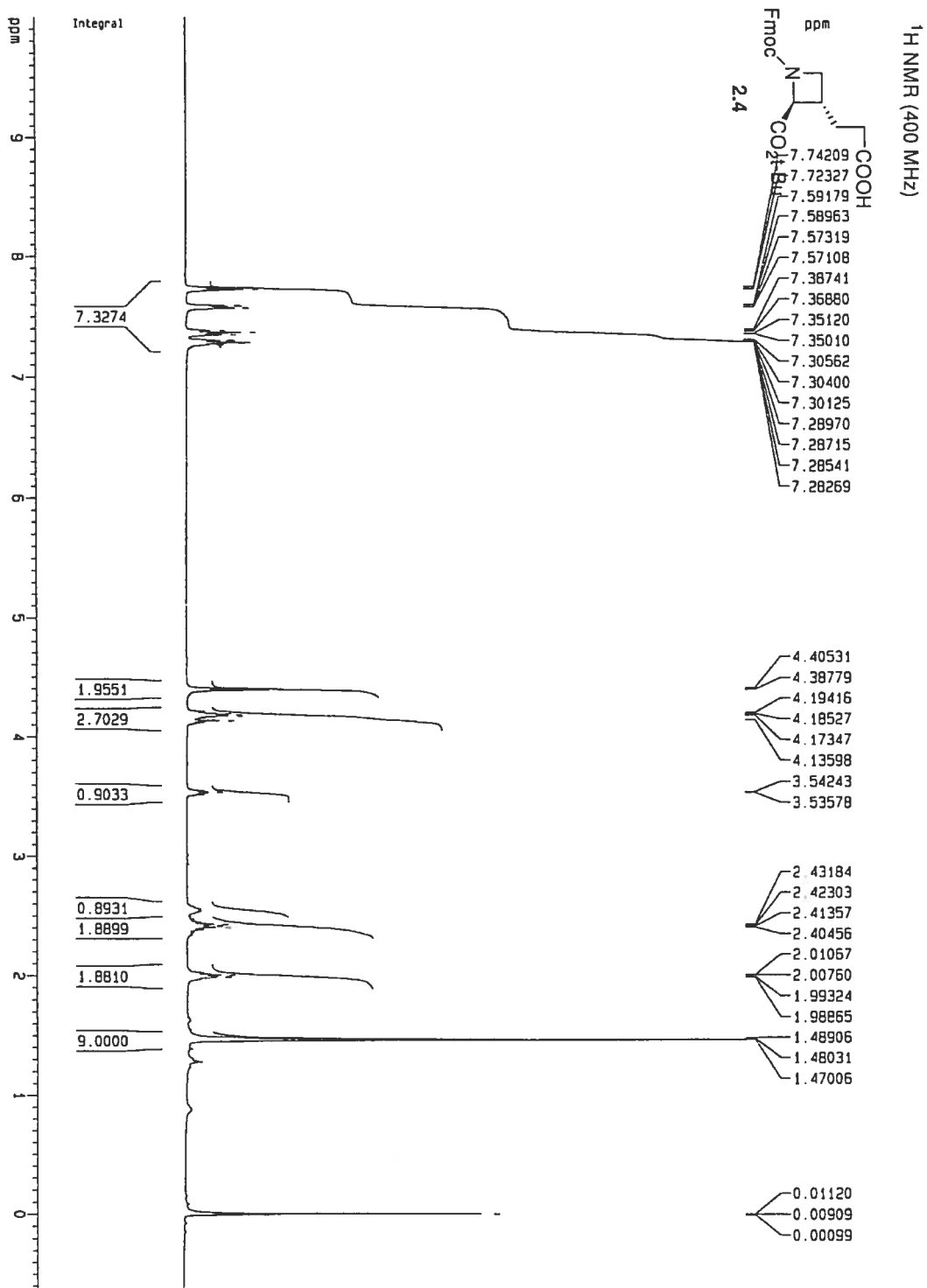

<sup>13</sup>C NMR (400 MHz)

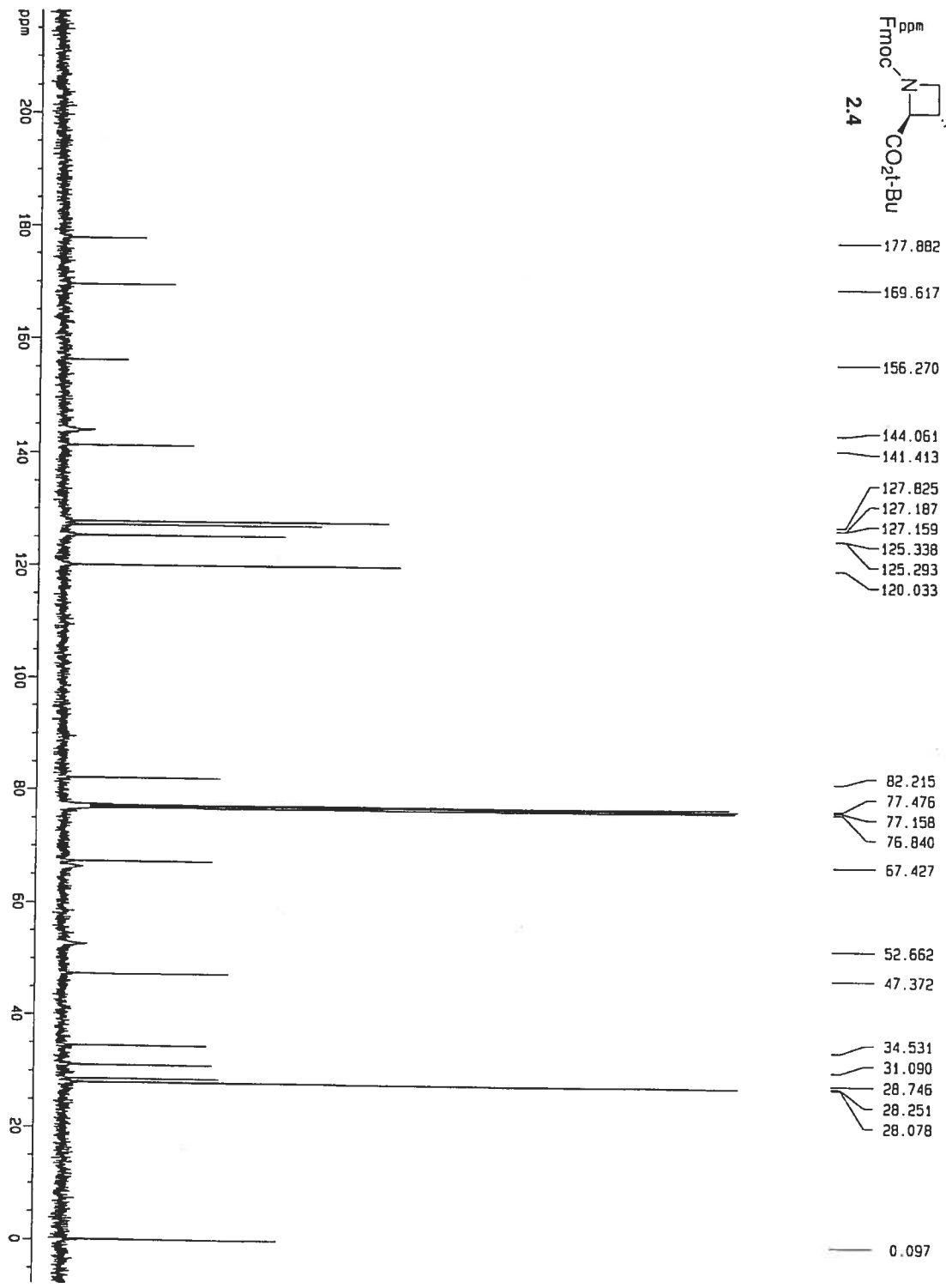
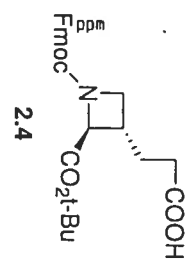

**Appendix 2**

**$^1\text{H}$  NMR and  $^{13}\text{C}$  NMR and HRMS of compounds related to  
chapter 3**

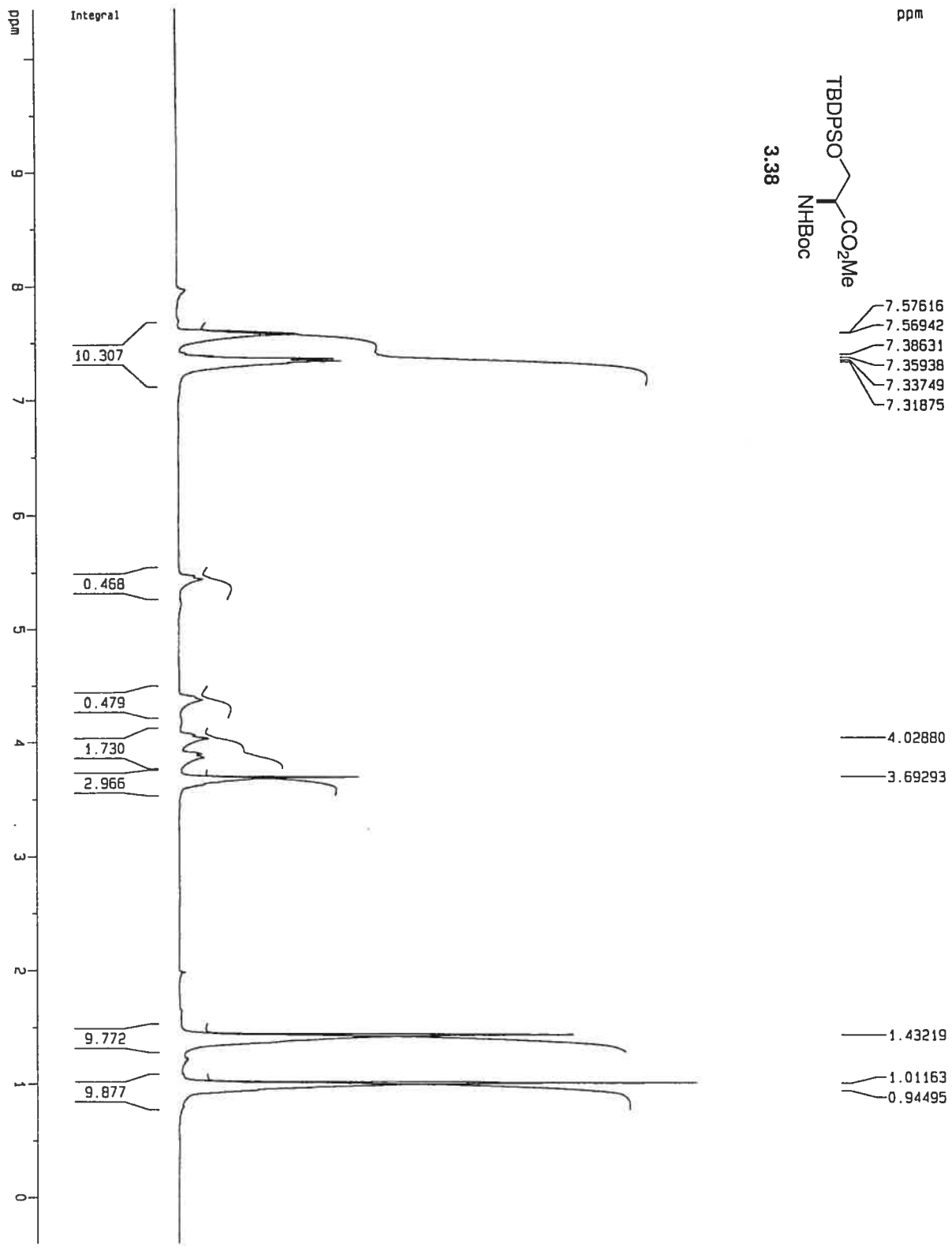







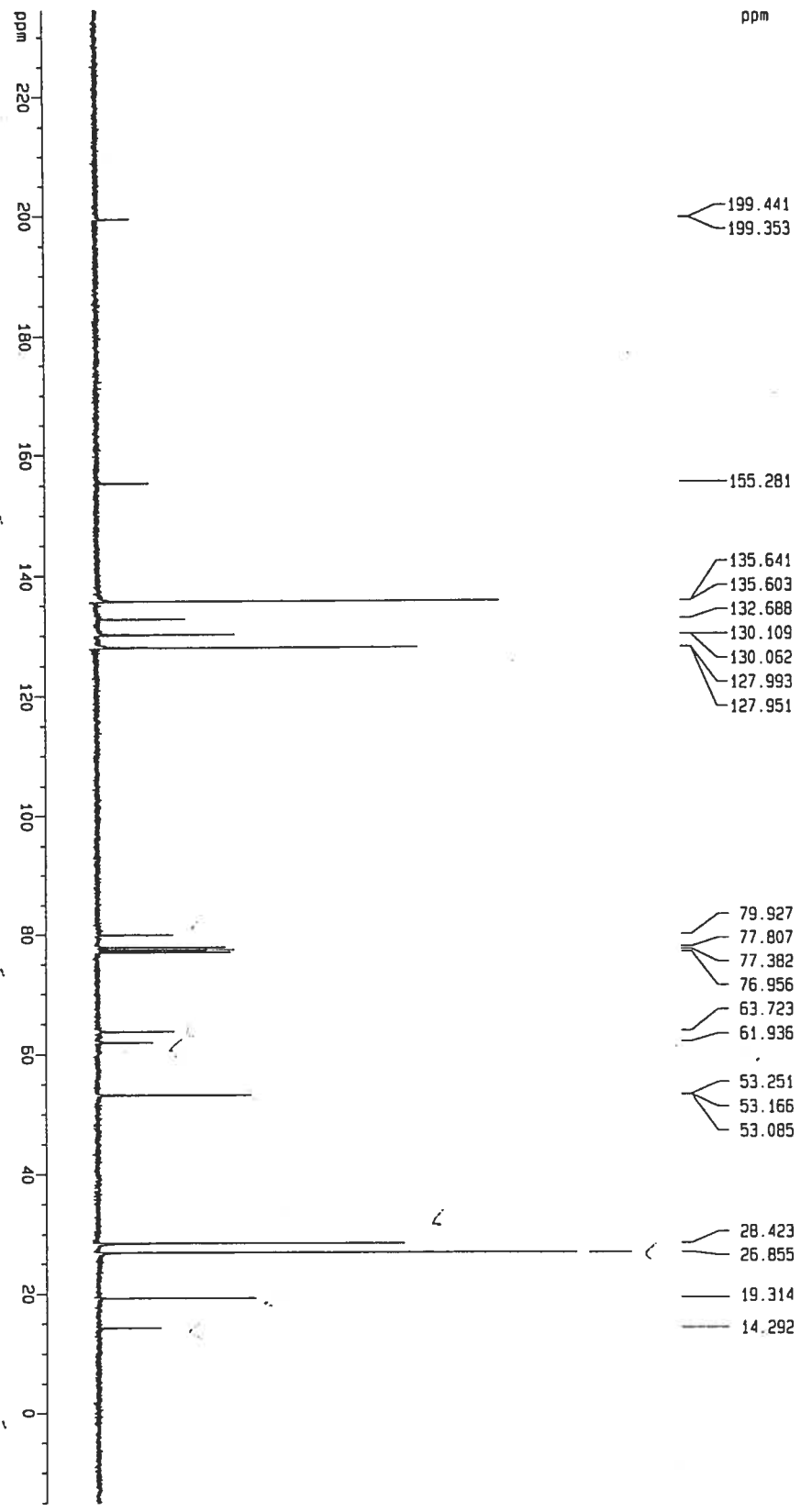
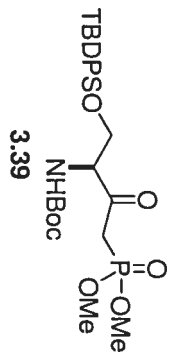

Sample Name Z5320 Sample Location P1-A1 Sample ID Operator Alax  
 Data File Name d:\PE\_Sciex\_Data\Projects\1oct\_2005\Data\Z5320\Wf\_Acq\_Time\_October\_31\_2005\_09:19:23.LM  
 Method C:\Program Files\Sciex\MSDCHEM\Software\Method\Method1.mtc.c.xml

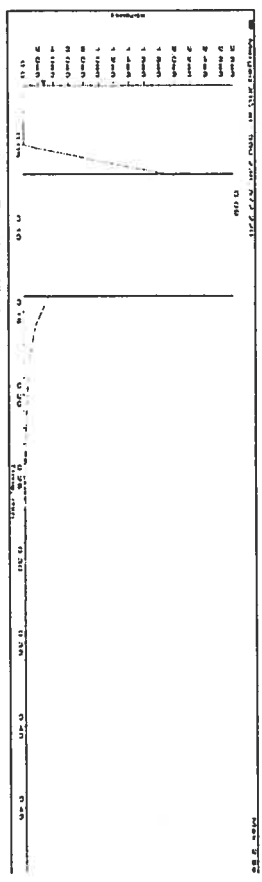

Merged XIC, Period# : 1 Experiment# : 1

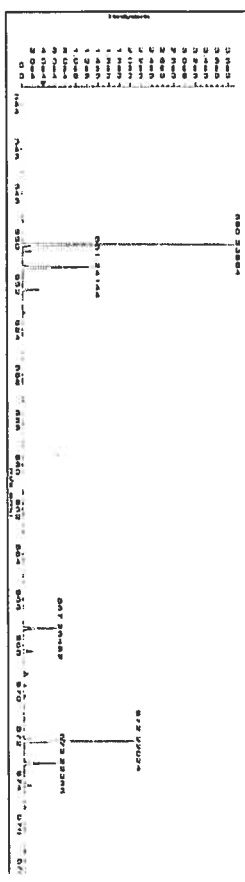
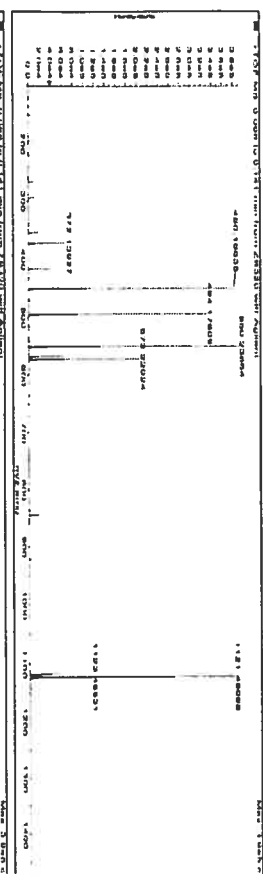

Formula	Compound name	Mass	Peak RT (min)	Peak area	Description
C27H40NO7PSi	-	549.23117	0.09	8.57980 E6	-

Species	Abundance (counts)	Ion Mass	Measured Mass	Error (mDa)	Error (ppm)	Ret. Time Error (min)
[M+H] <sup>+</sup>	408673.32	550.23864	550.23864	0.00019	0.35	-
[M+Na] <sup>+</sup>	216469.34	572.22039	572.22024	-0.00015	-0.26	-



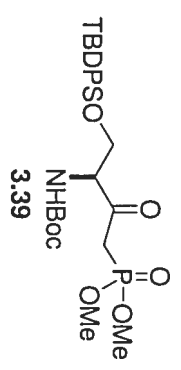

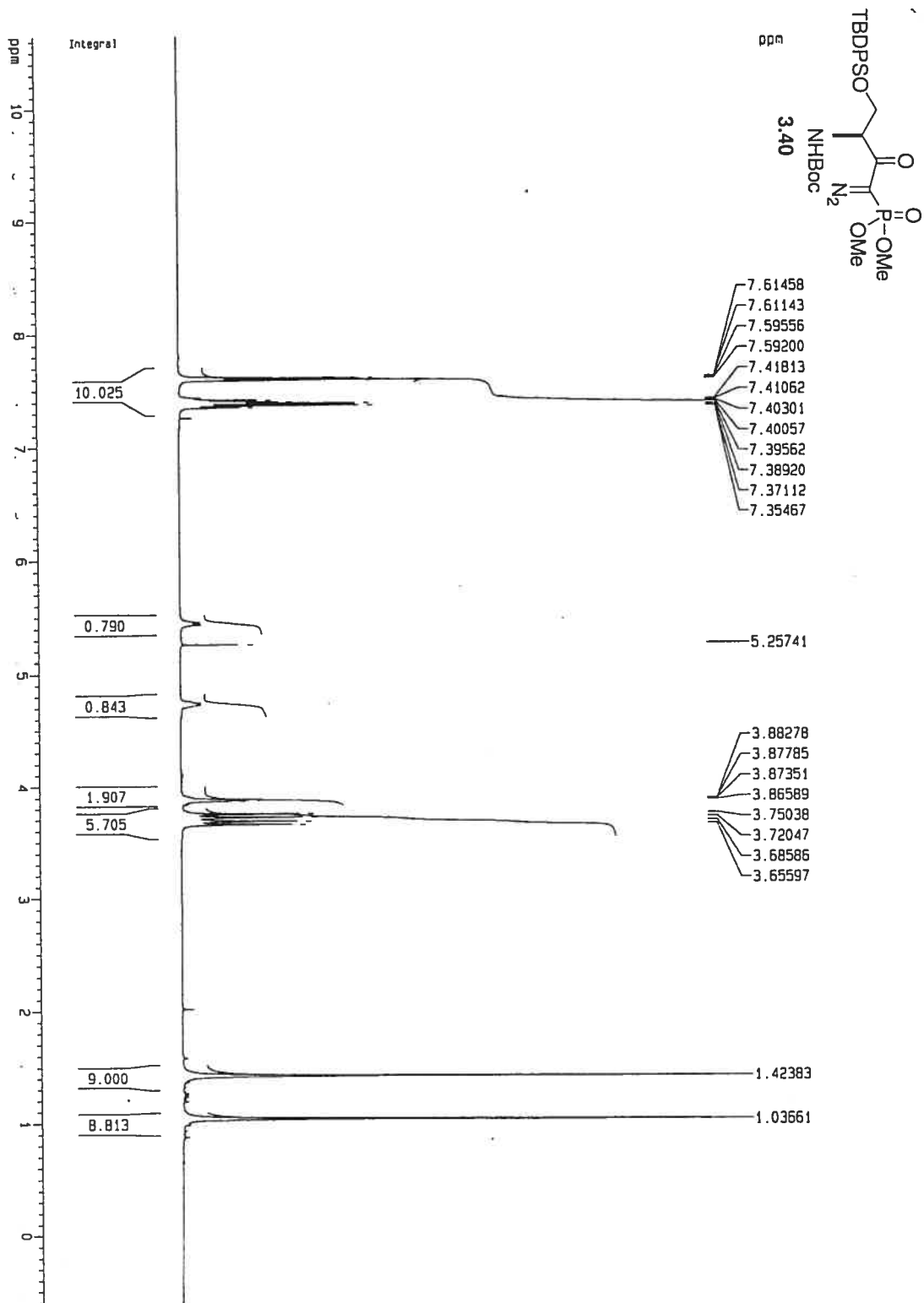

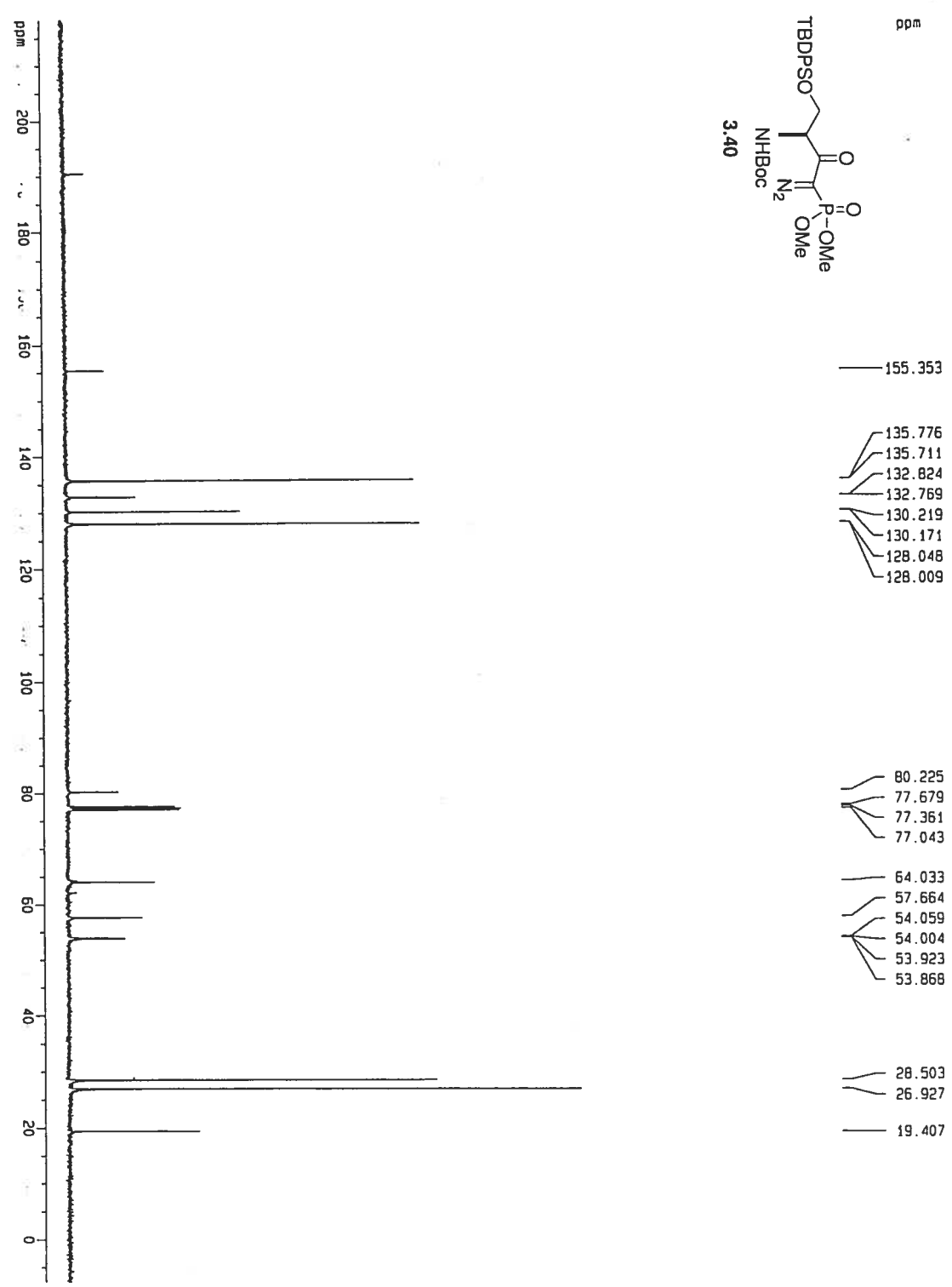
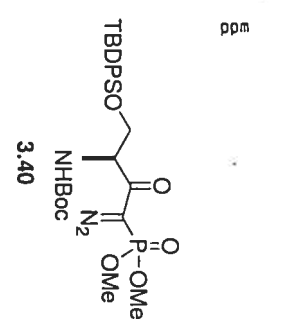

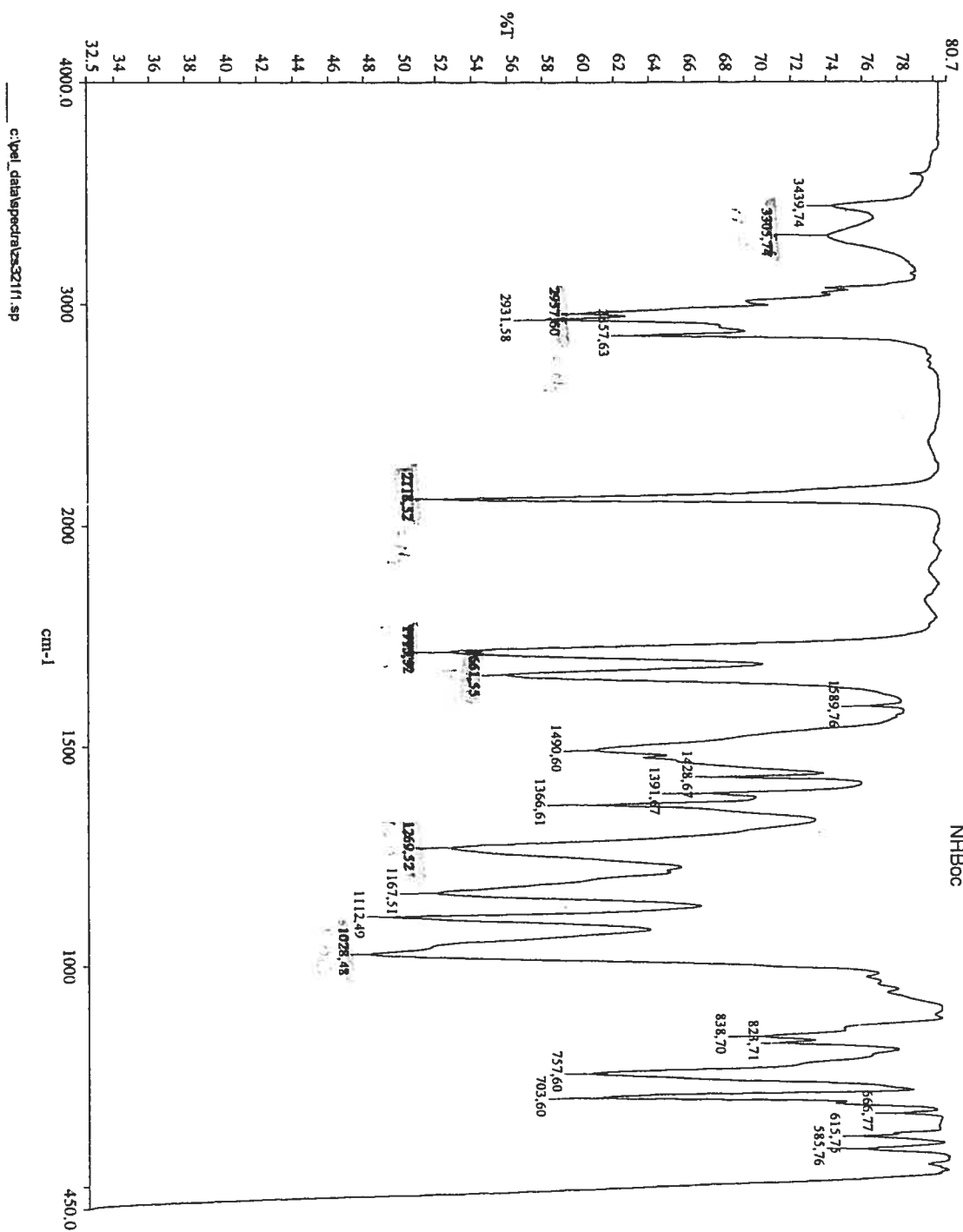
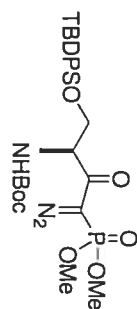

c:\pel\_delta\spectra\vs32111.sp



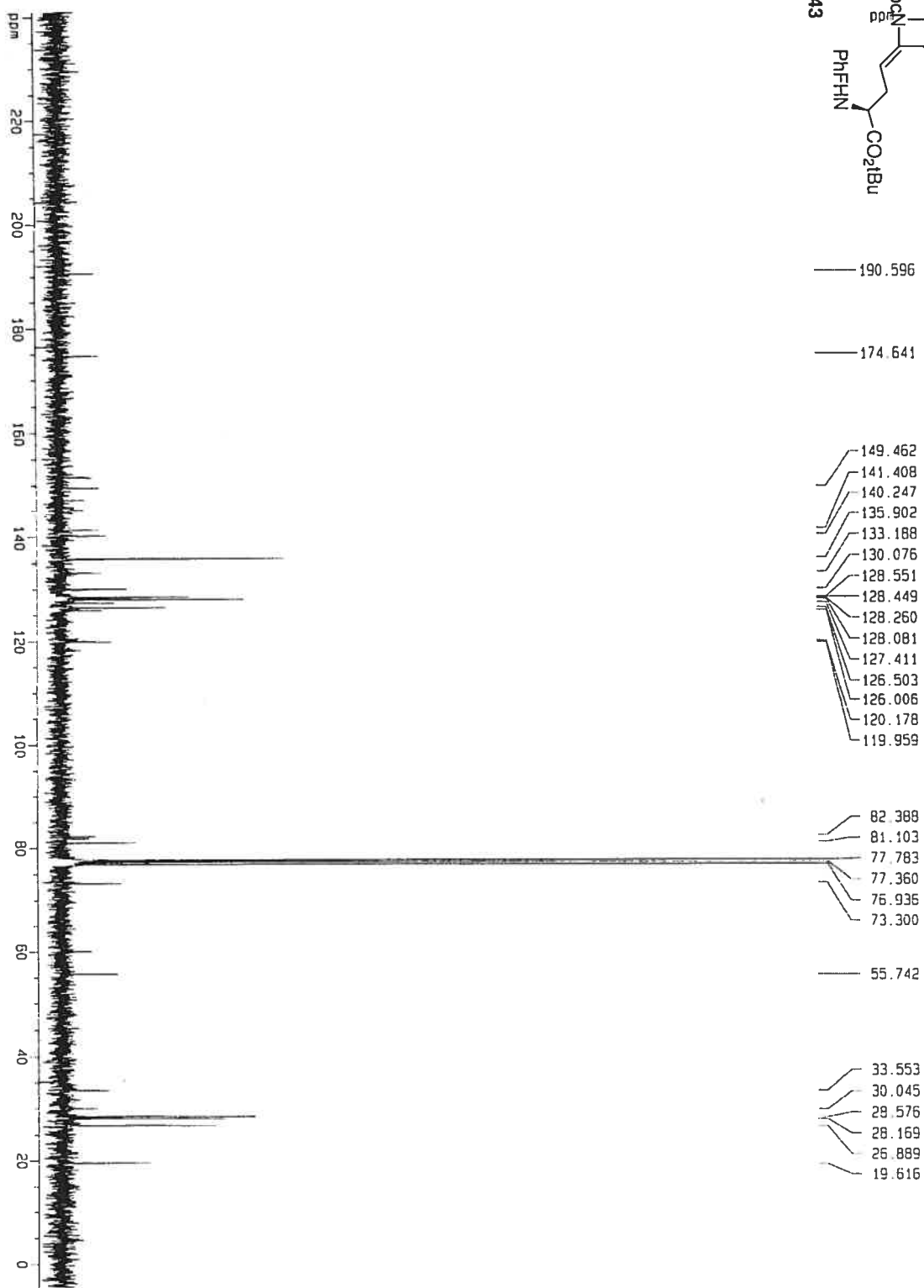
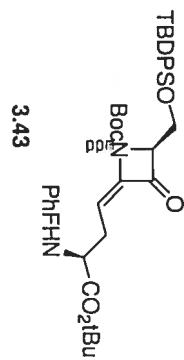



Sample Name: 231213 Sample Location: P1-A3 Sample ID: Operator: Max  
 Method: C:\Program Files\Meridian\MSL\Software\MethodDevelopment\mslmethod1.cfm  
 Time: 09:49:41.2803, 03/11/05, PM

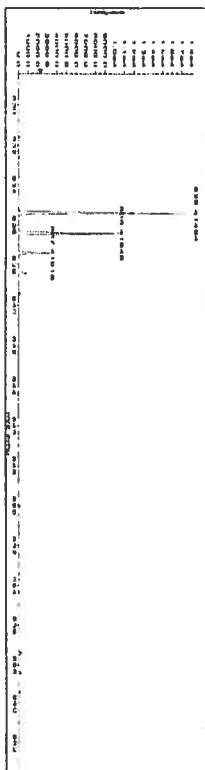
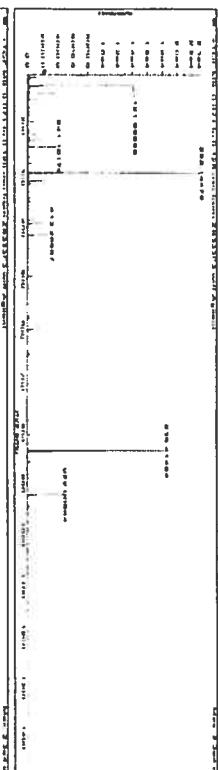
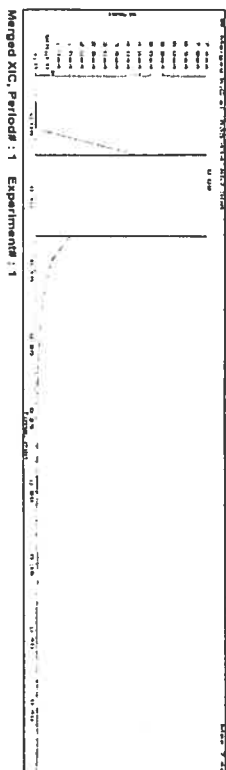

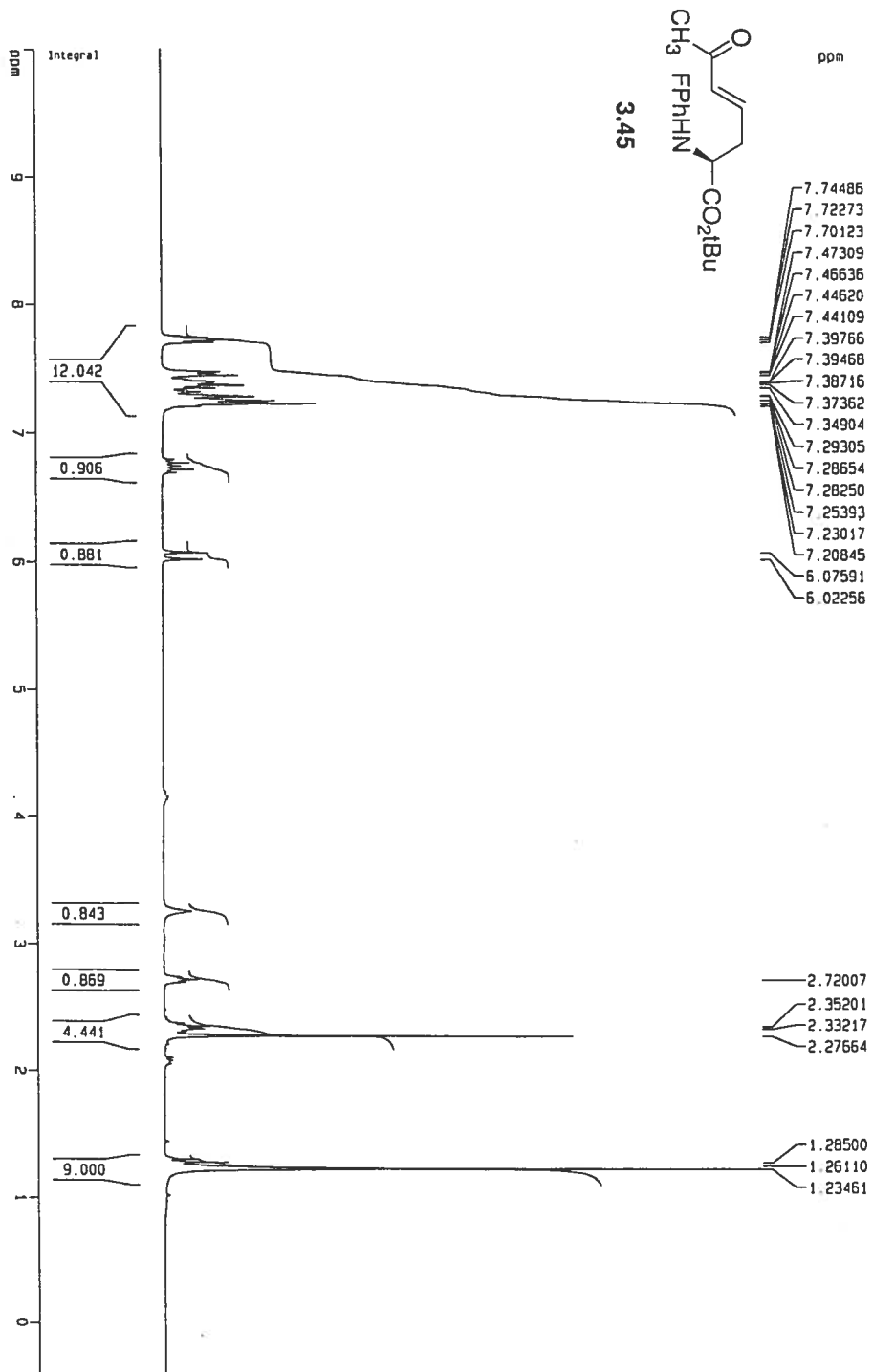

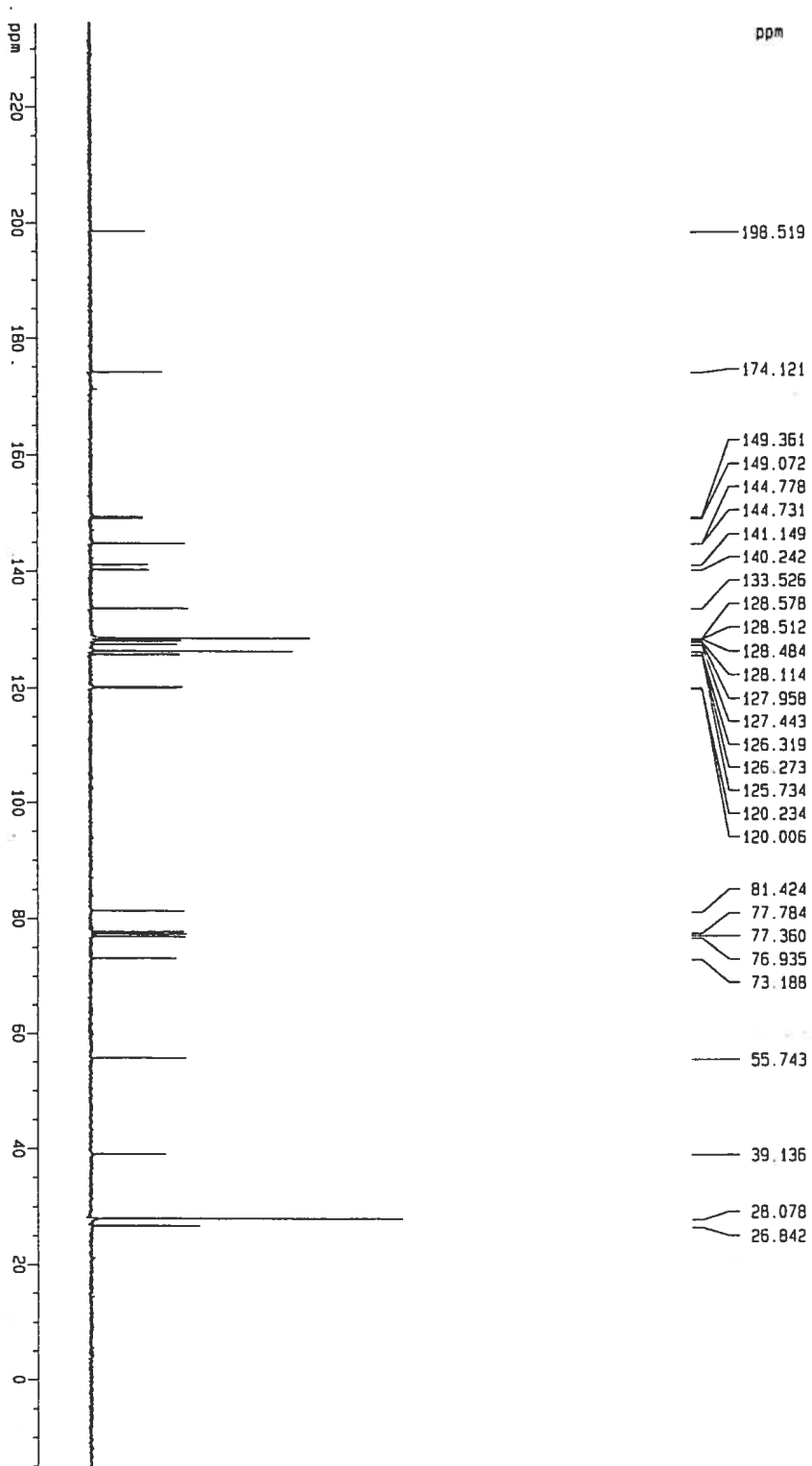
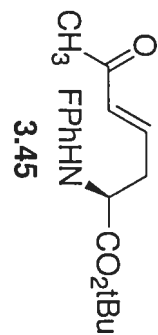

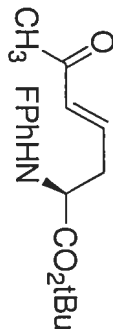

3.45

Sample Name: 25432 Sample Location: P1-C2 Sample ID: Operator:  
 Data File Name: 617E\_Specs\_Data\_Program: 20060202\MSDCHEM\AcqTime\_Match\_022006\_021349.PM  
 Method: C:\Program Files\Agilent\MSDCHEM\bin\msdchem\bin\msdchem.exe

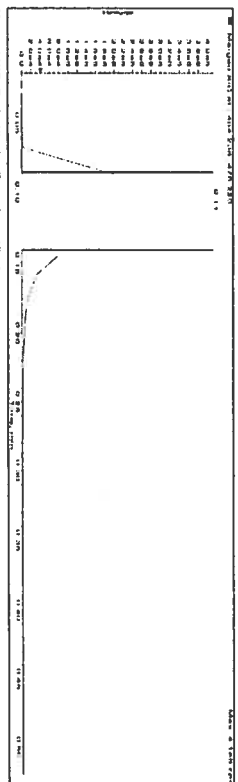

Merged XIC, Period: 1 Experiment: 1

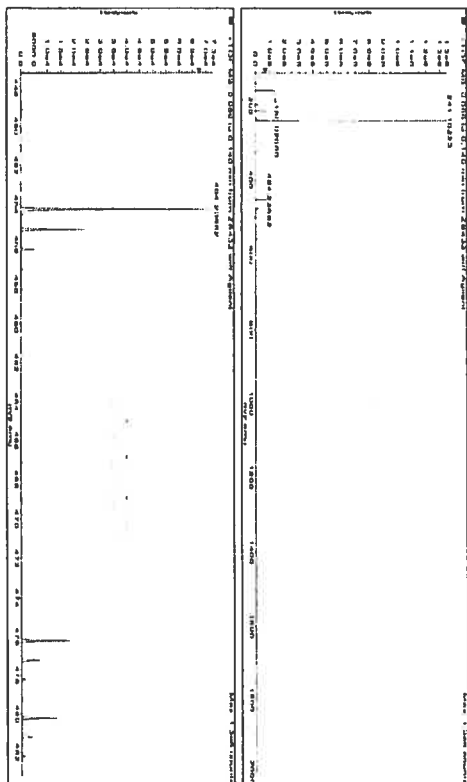

Formula	Compound name	Mass	Peak RT (min)	Peak area	Description
C20H21NO3	---	453.23039	0.11	1.0871E9	---

  

Species	Abundance (counts)	Ion Mass	Measured Mass	Error (mDa)	Error (ppm)	Rel. Time Error (min)
[M+H] <sup>+</sup>	7342.58	454.21767	454.23082	-0.00086	-1.86	---
[M+NH] <sup>+</sup>	1901.07	476.21981	476.21898	-0.00063	-1.33	---

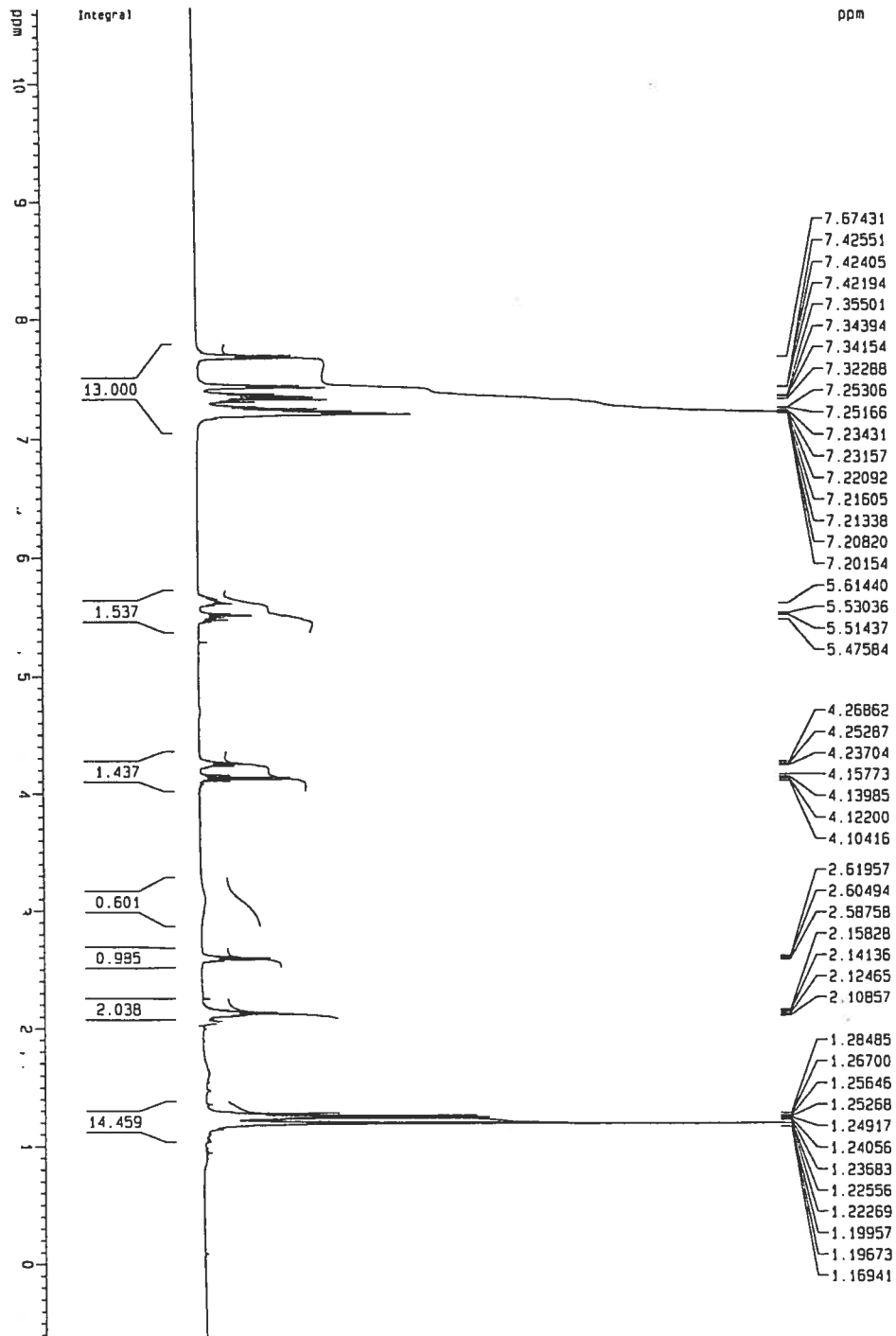
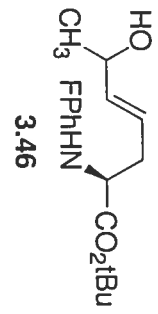

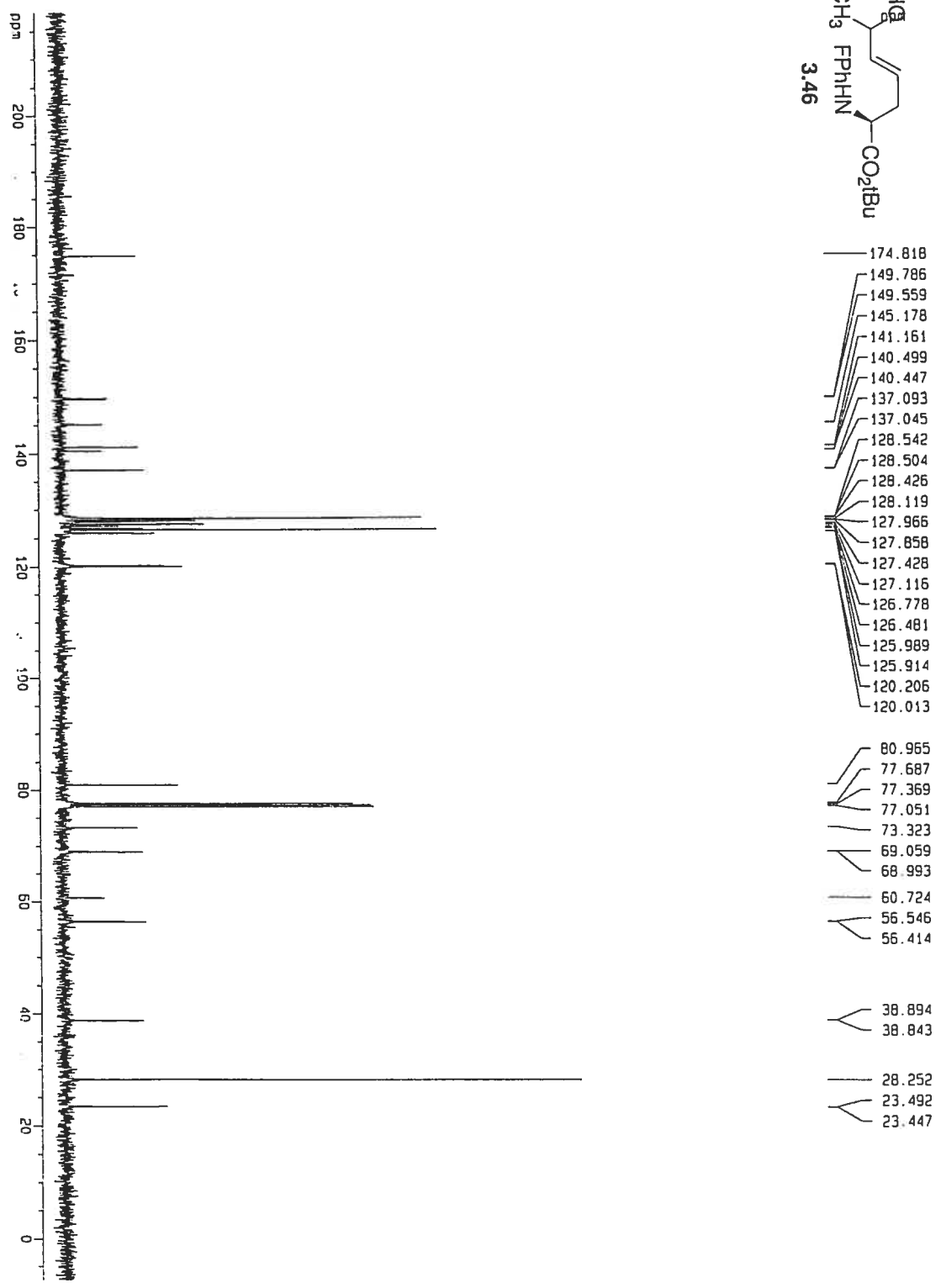
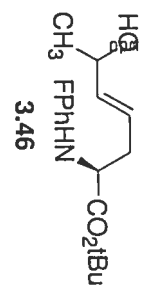

Sample Name Z5441 Sample Location P1-E3 Sample ID Operator  
 Data File Name d:\PE\_SciX Data\Project15101ev\_200604a\Z5441\_3.wiff Acq Time: February 01, 2006, 10:14:53 AM  
 Method C:\Program Files\Agilent\MSDCHEM\bin\msdchem.exe

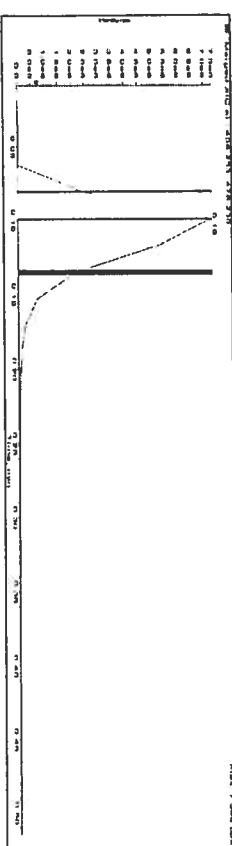

Merged XIC, Period# : 1 Experiment# : 1

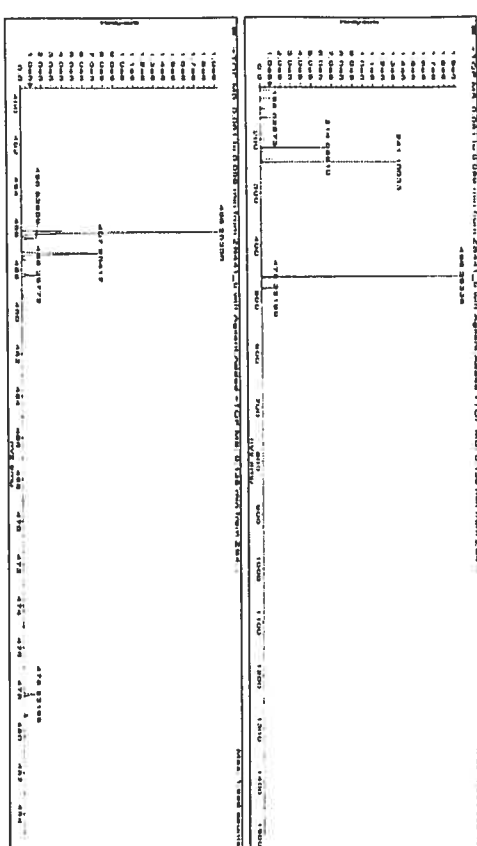

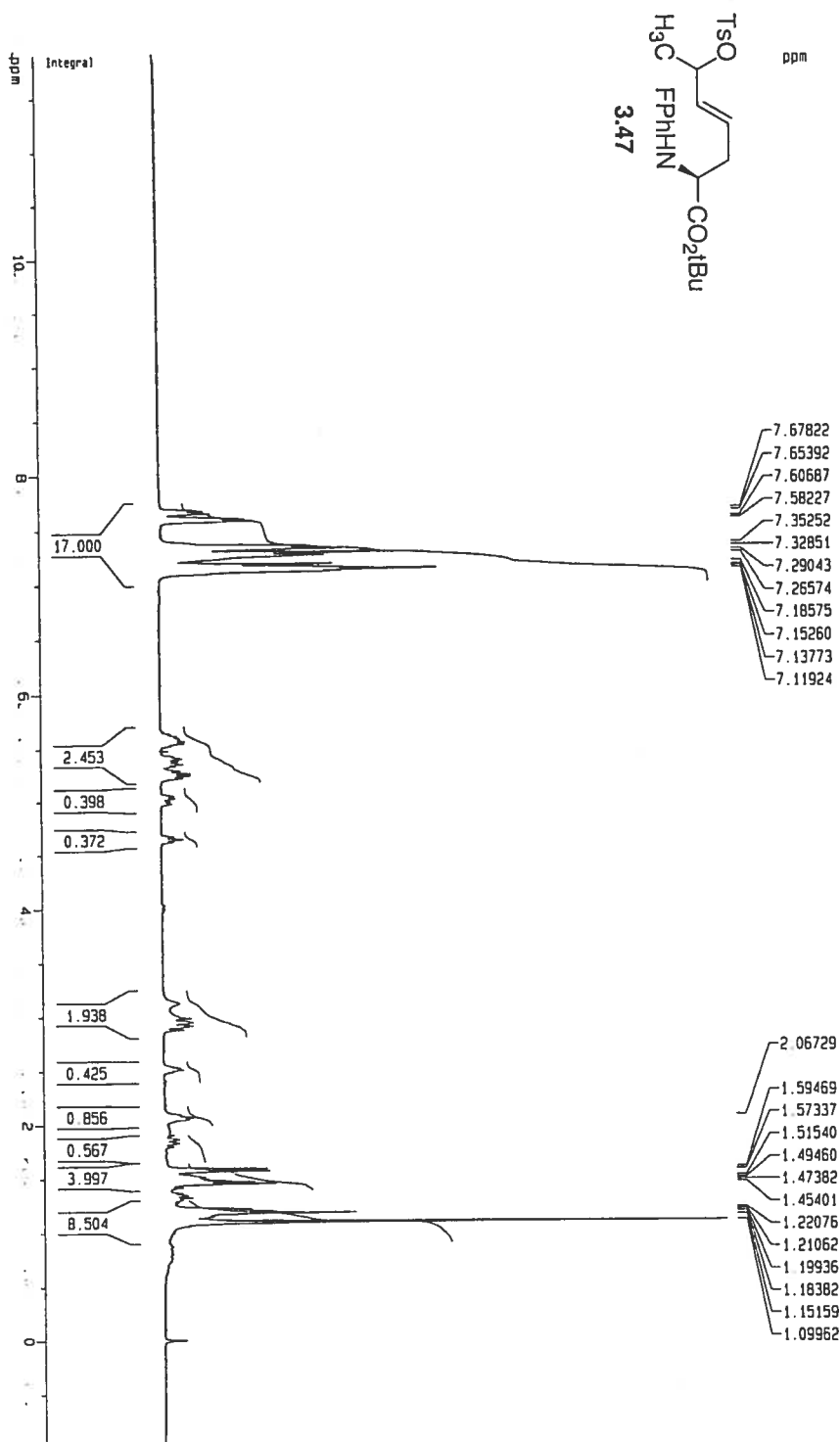



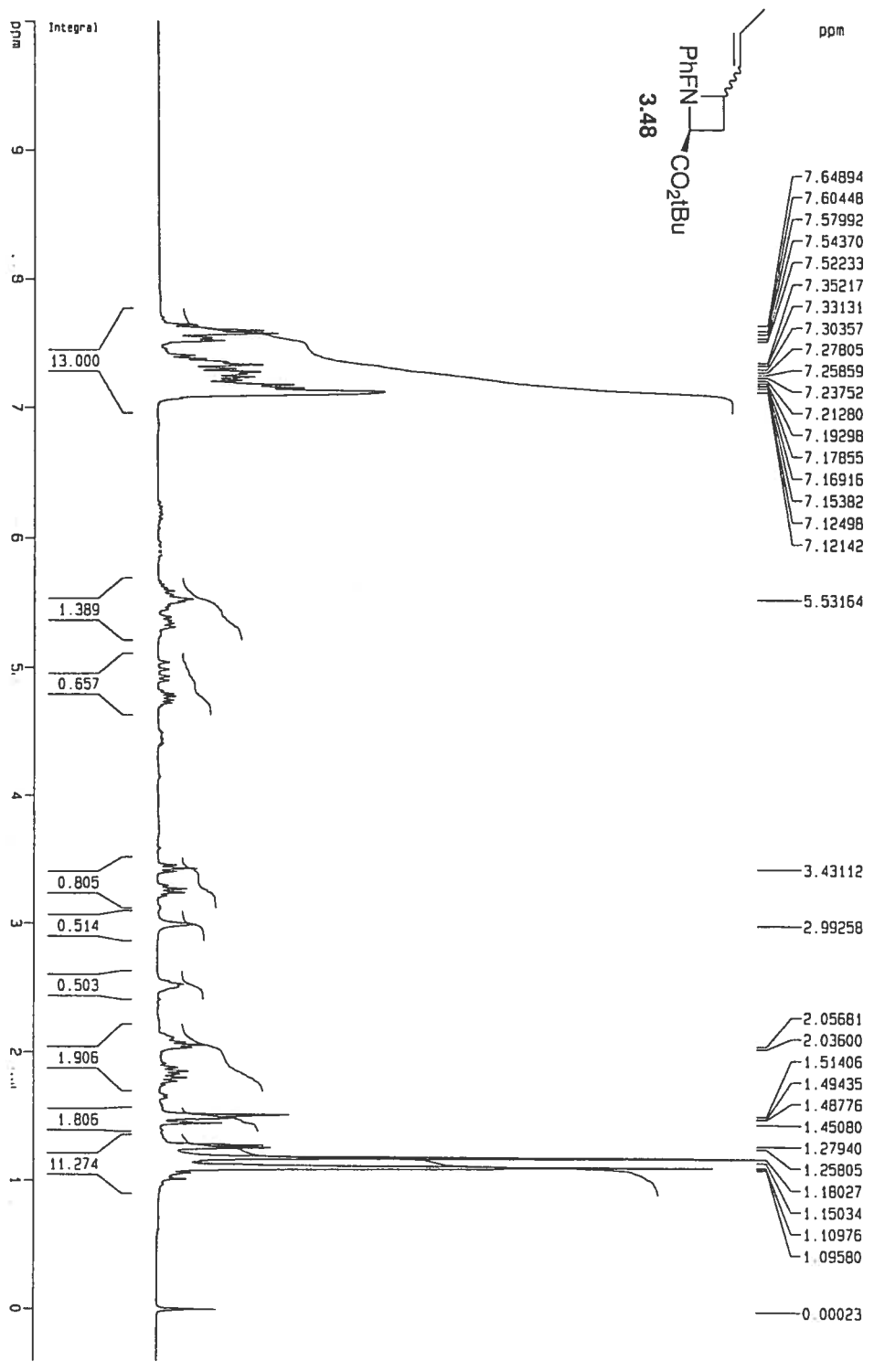

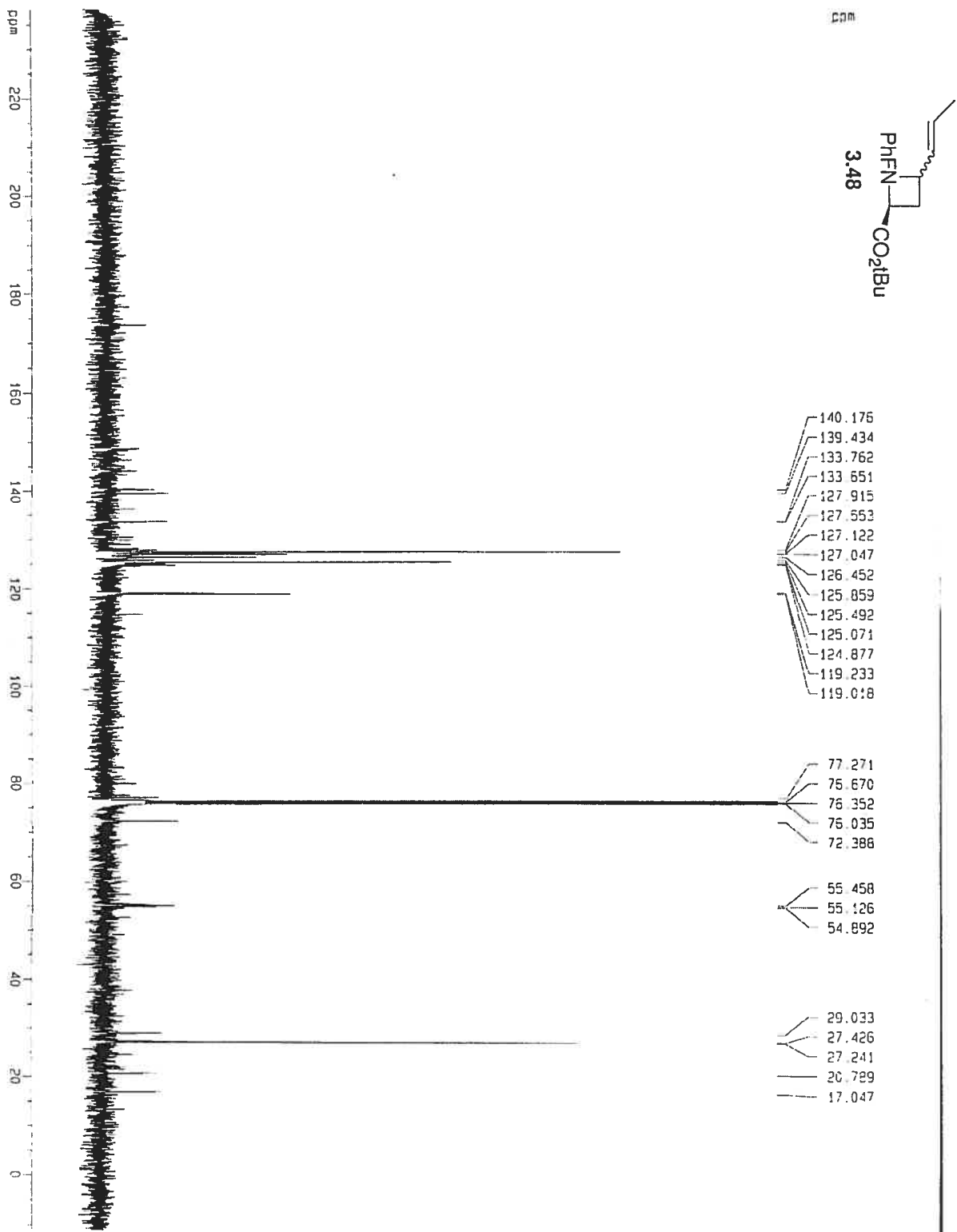

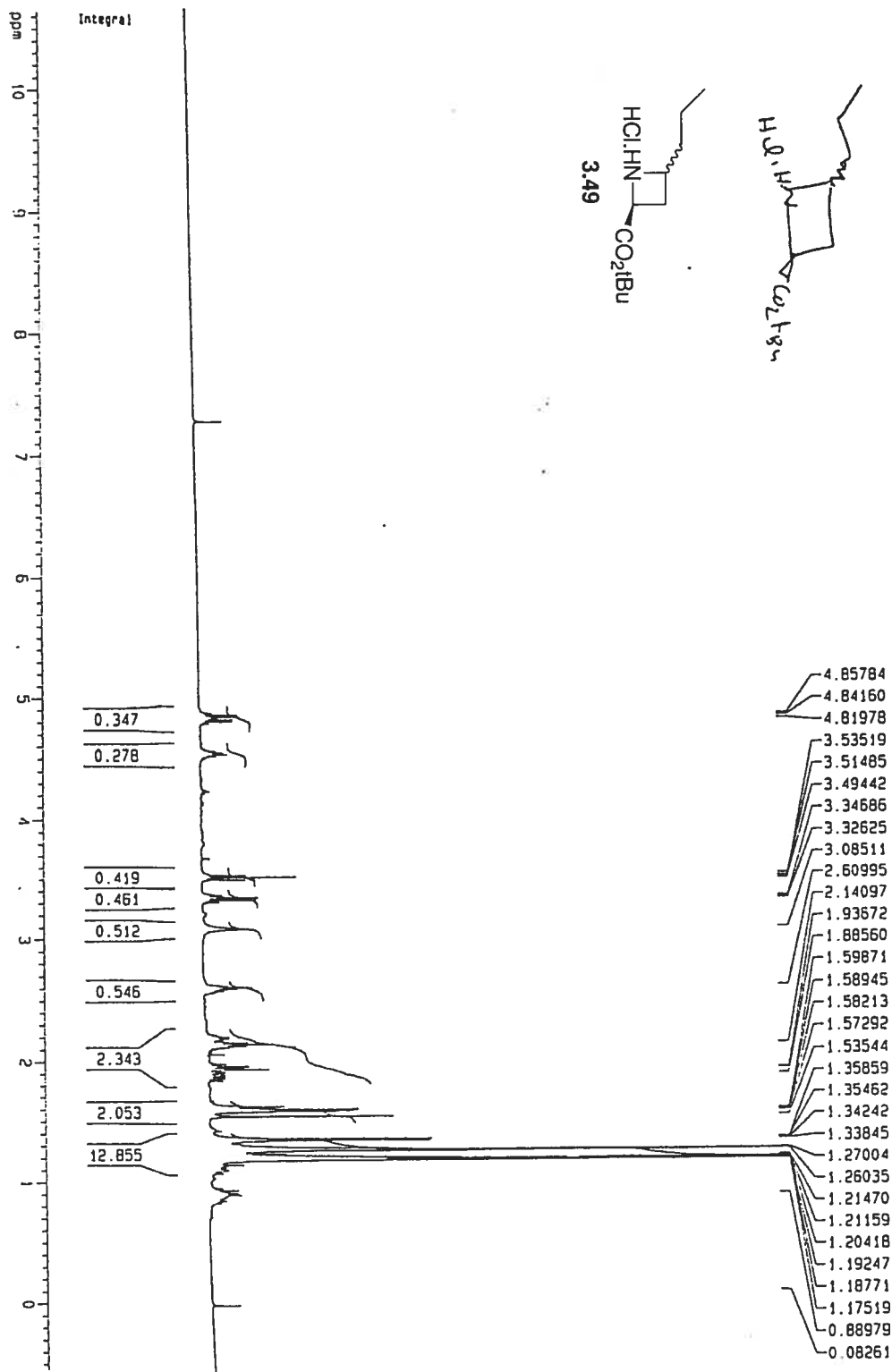

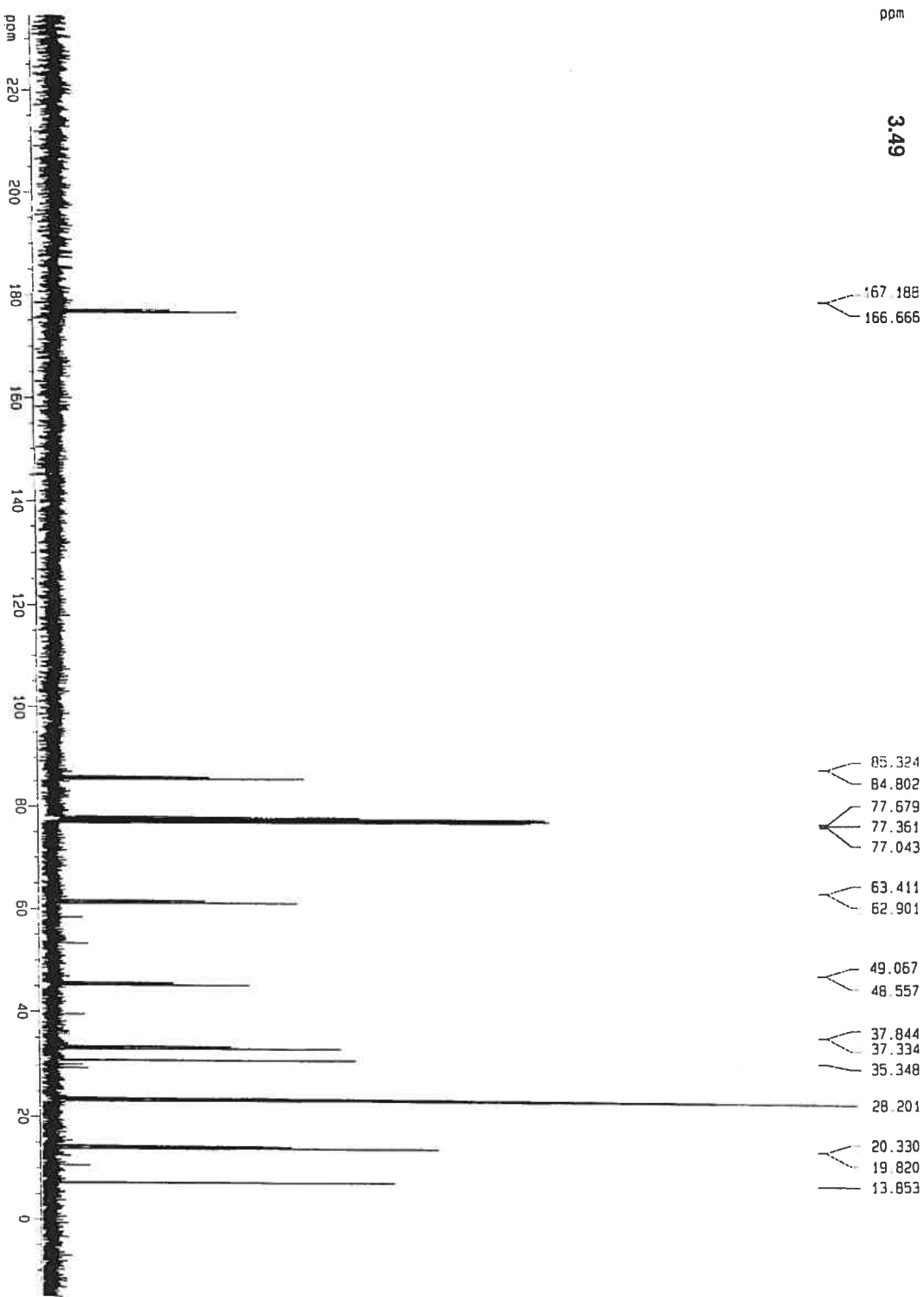





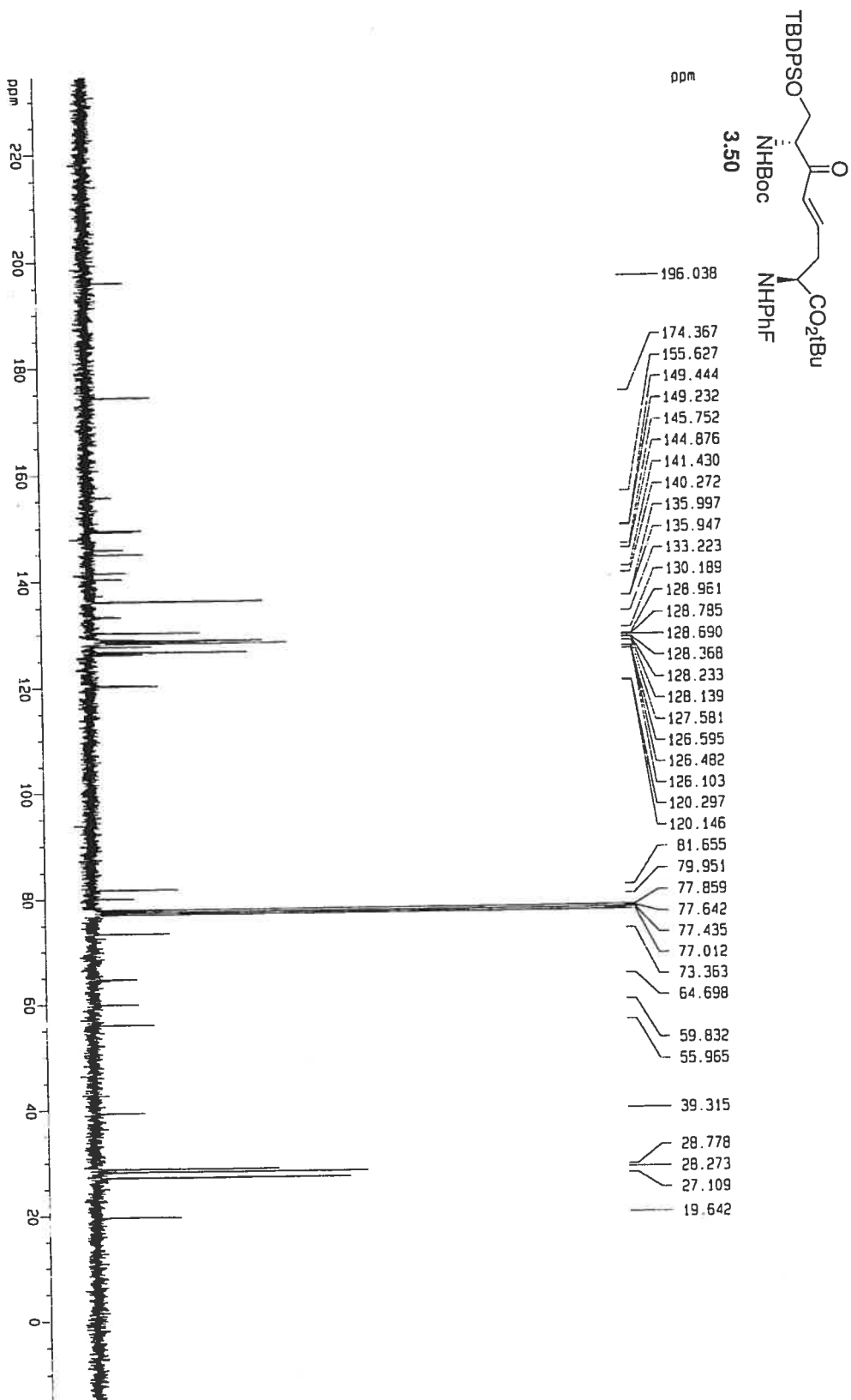

Empirical Formula Confirmation Report

Sample Name: Z5344 Sample Location: P1-C23 Sample ID: Operator:  
 Data File Name: d:\PE Data\Projects\Q2\MSL\_Z000\DATA\Z5344.ms Acq Time: March 02 2006, 02:17:24 PM  
 Method: C:\Program Files\Agilent\MSDCHEM\MSDCHEM\MSDCHEM1.M

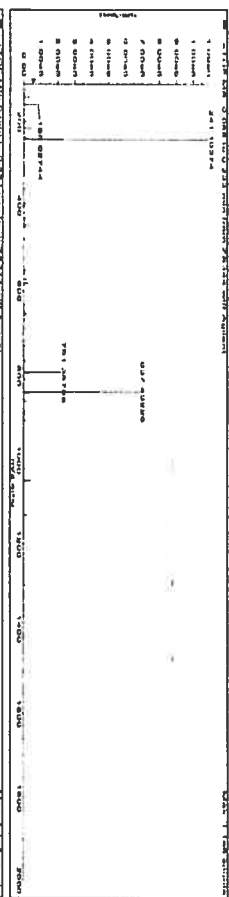
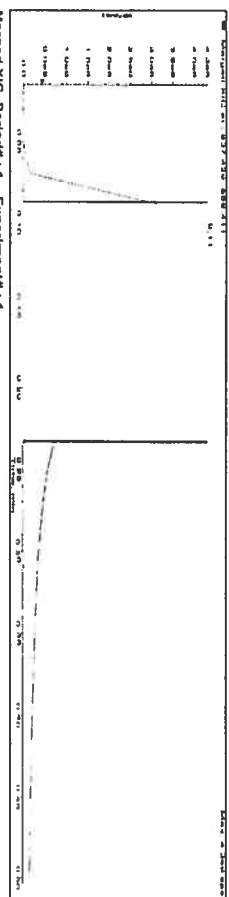



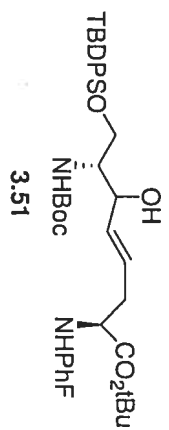

Xci

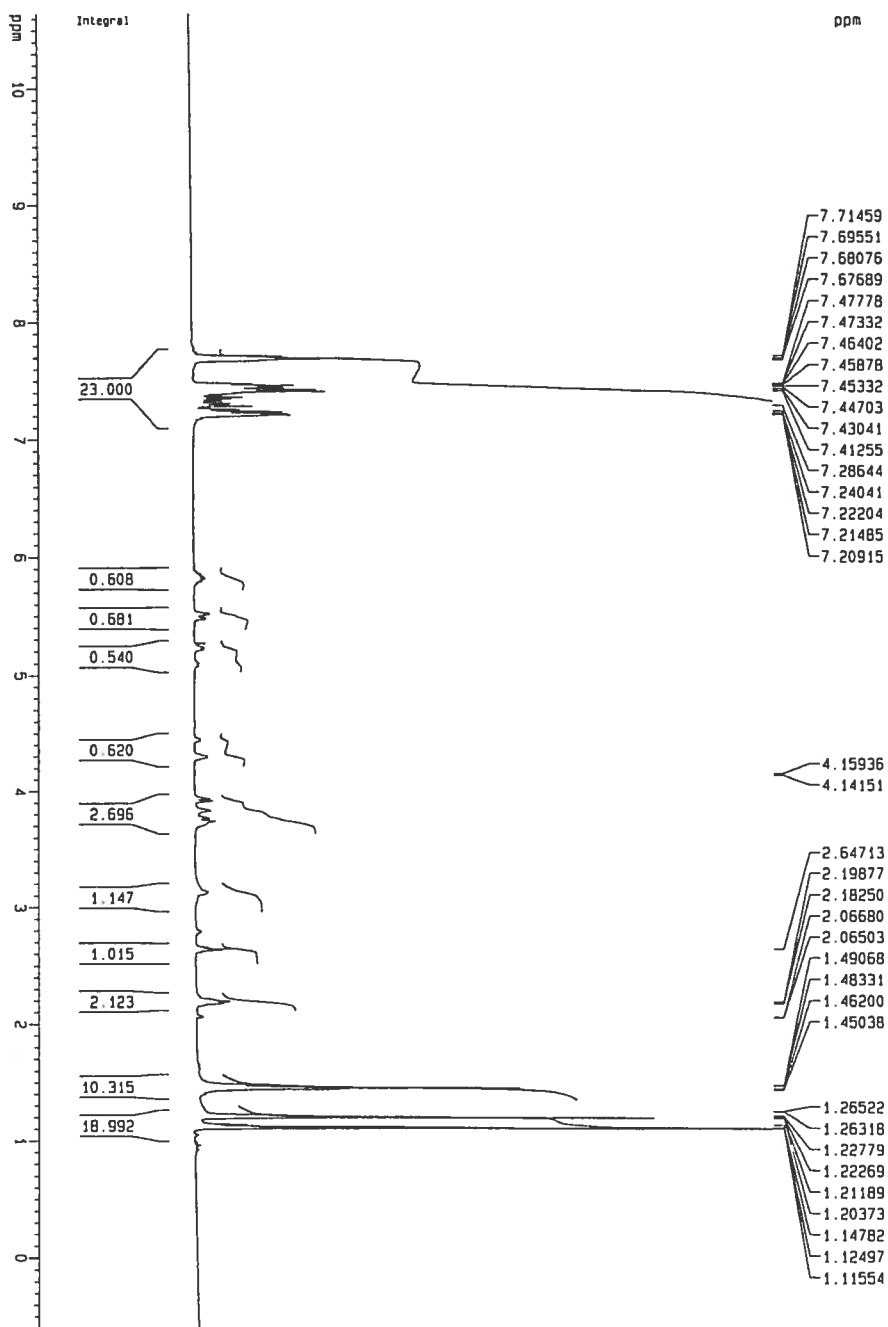

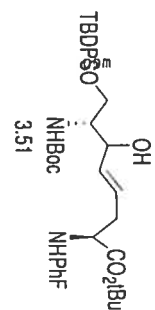
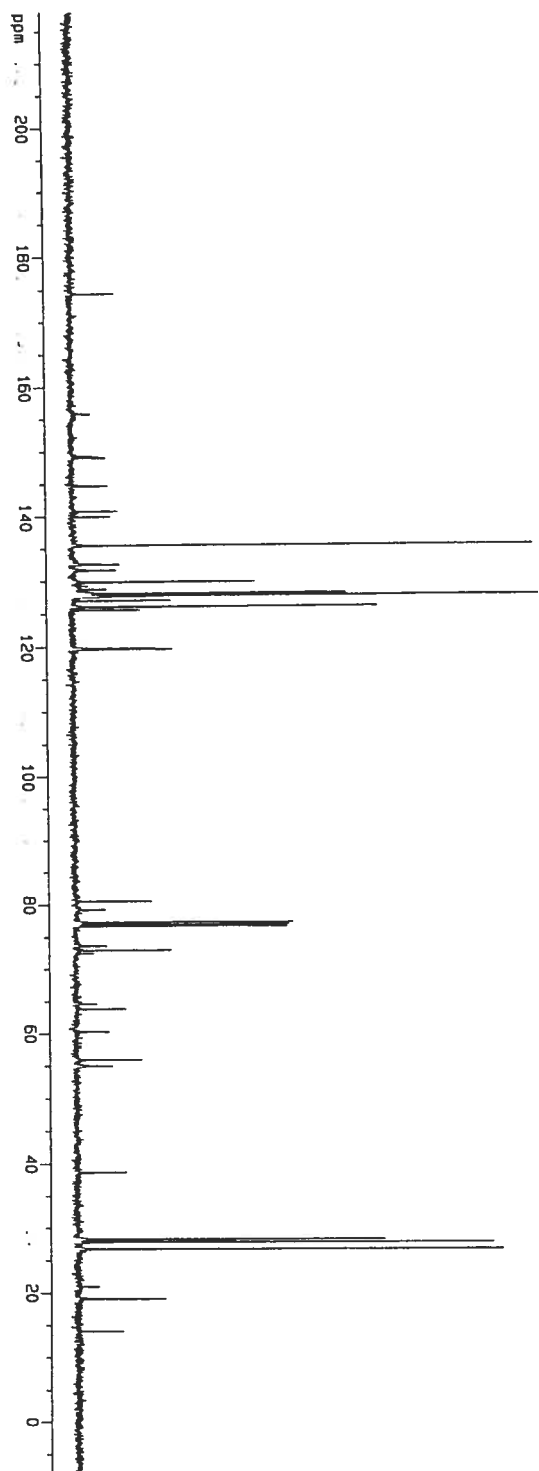

174.412

149.116  
144.744  
140.826  
139.966  
135.460  
132.741  
132.543  
131.709  
129.859  
128.777  
128.147  
128.013  
127.775  
127.696  
127.621  
127.010  
126.095  
125.574  
119.784  
119.598

80.537  
79.294  
77.322  
77.004  
76.686  
73.656  
72.962  
63.823  
60.287  
55.982  
55.013

38.694

28.298  
27.838  
26.796

19.101

14.119

Empirical Formula Confirmation Report

Sample Name: 264374 Sample Location: P1-E5 Sample Id: Operator  
 Data File Name: 418E\_Spex\_Data\Project\0176\_2008\data\264374\_1\_0\_Wf\_Acq\_Time\_February\_01\_2006\_10:17:38.AM  
 Method: C:\Programme\EI\MSDCHEM1\TOP\_Software\ame\hodes\hodes\lham\lham1.exe

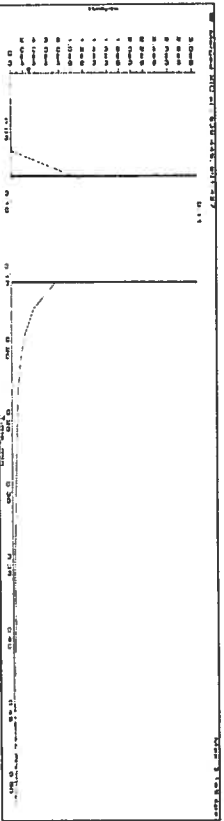

Merged XIC, Period: 1 Experiment: 1

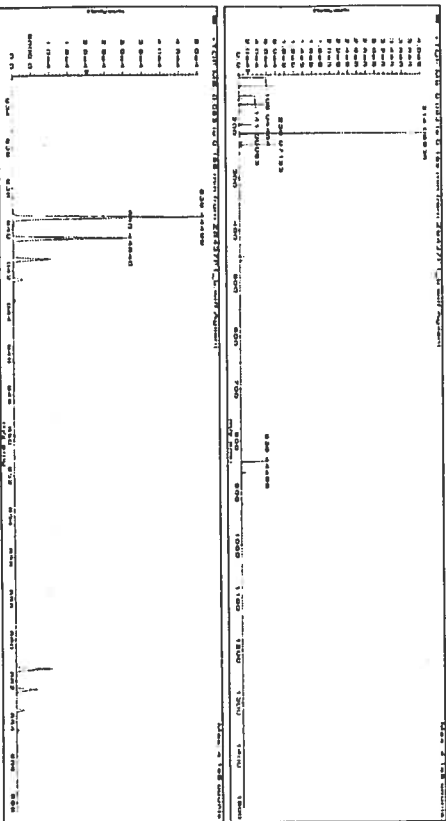

Formula	Compound name	Mass	Peak RT (min)	Peak area	Description	
C27H42NO6S		437.1	0.11	1.05672E6		
Species	Abundance (count)	Ion Mass	Measured Mass	Error (mDa)	Error (ppm)	Ret. Time Error (min)
[M+H] <sup>+</sup>	5606218	437.4460	437.4462	0.0002	0.00	
[M+NH] <sup>+</sup>	3942331	581.4264	581.4262	0.0002	0.79	

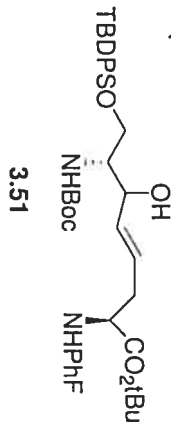

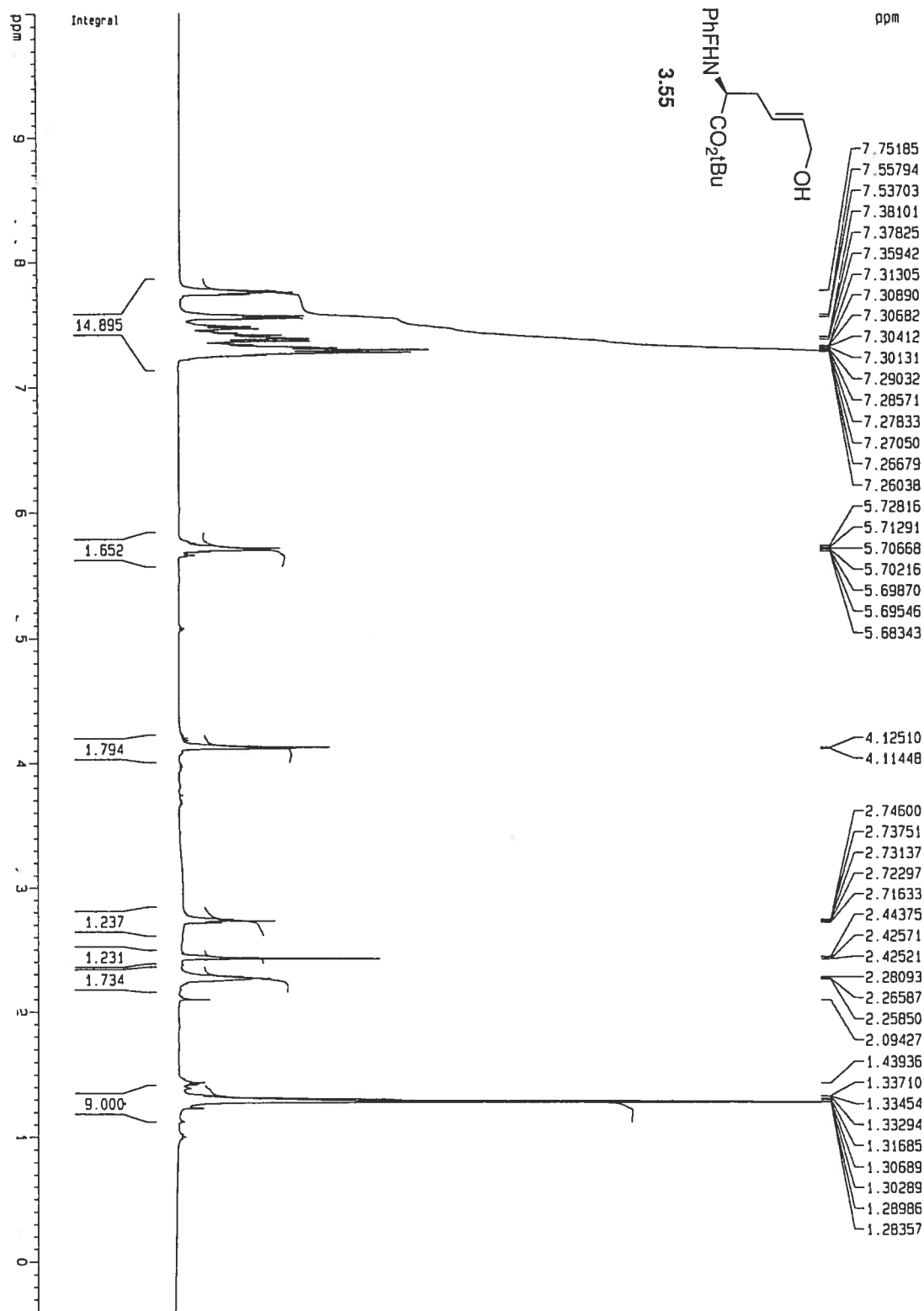

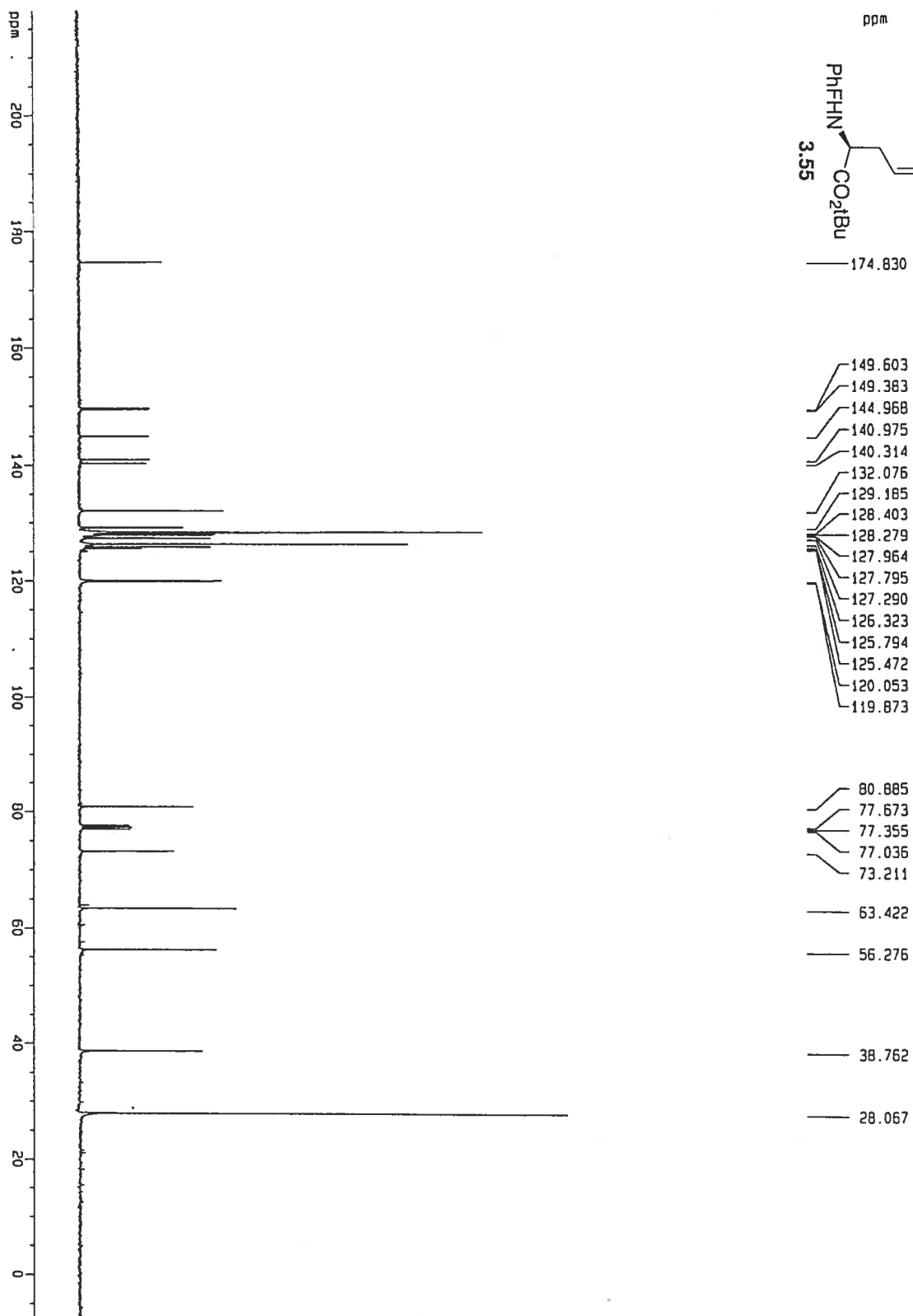

XCVI

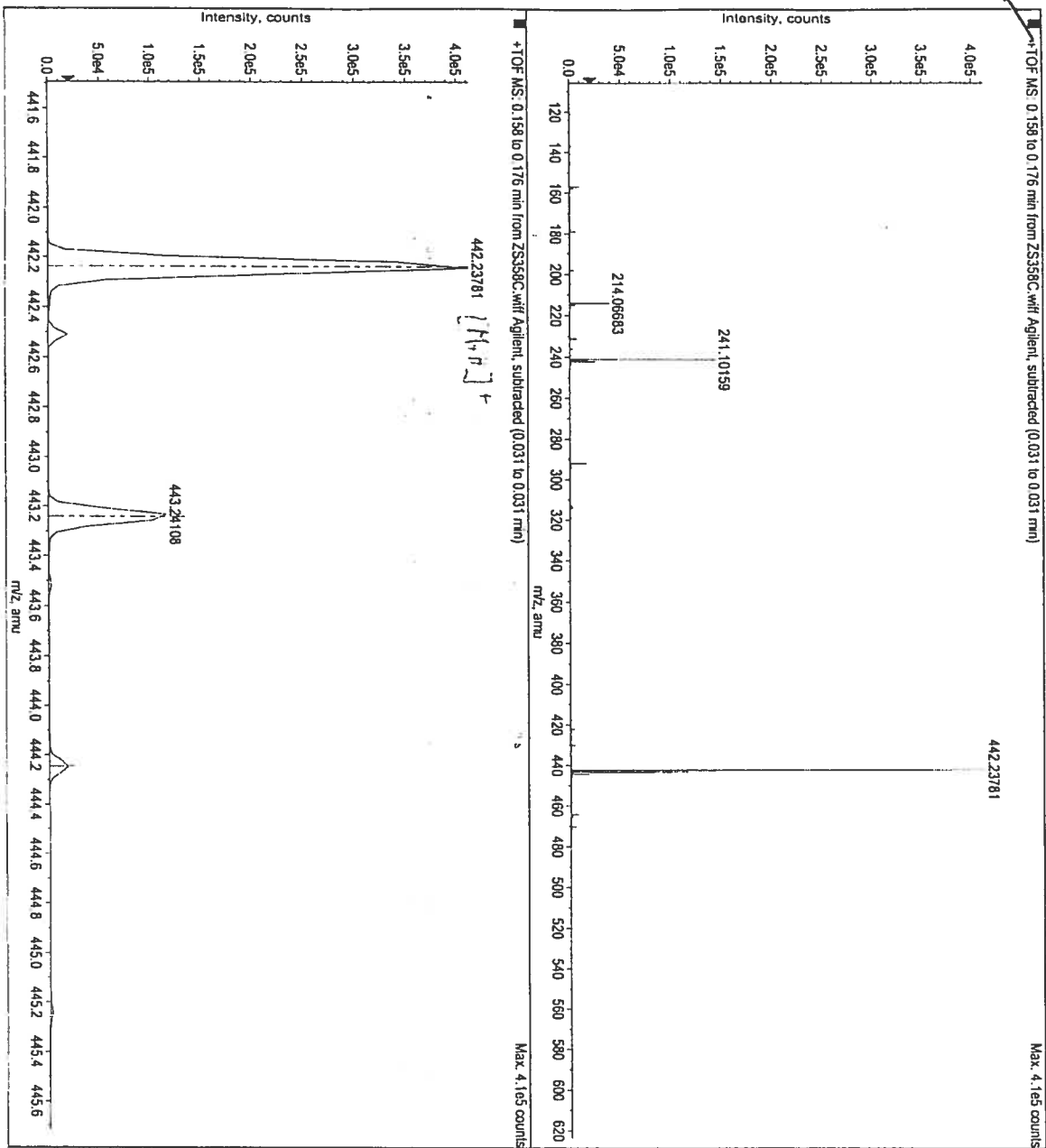
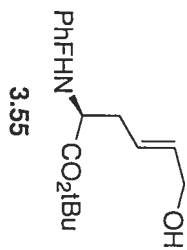

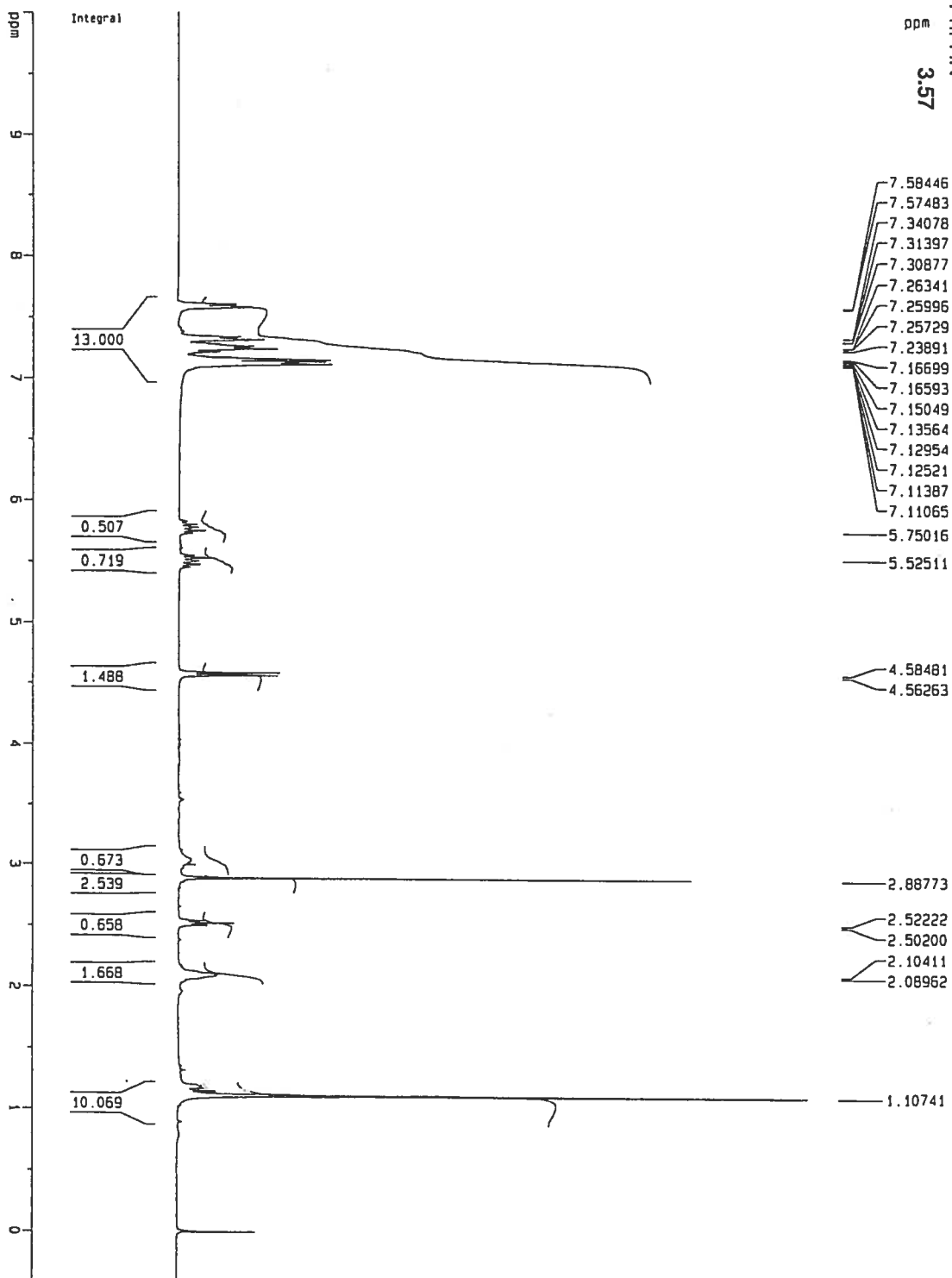

XCVII

C:\Ana Direct Injection\Data\ZS-360

05/12/2005 01:09:18 PM

ZS-360 #93-110 RT: 1.23-1.46 AV: 18 SB: 37 0.04-0.28, 2.64-2.91 NL: 1, 12E7  
T: + c ESI Full ms [100.00-800.00]

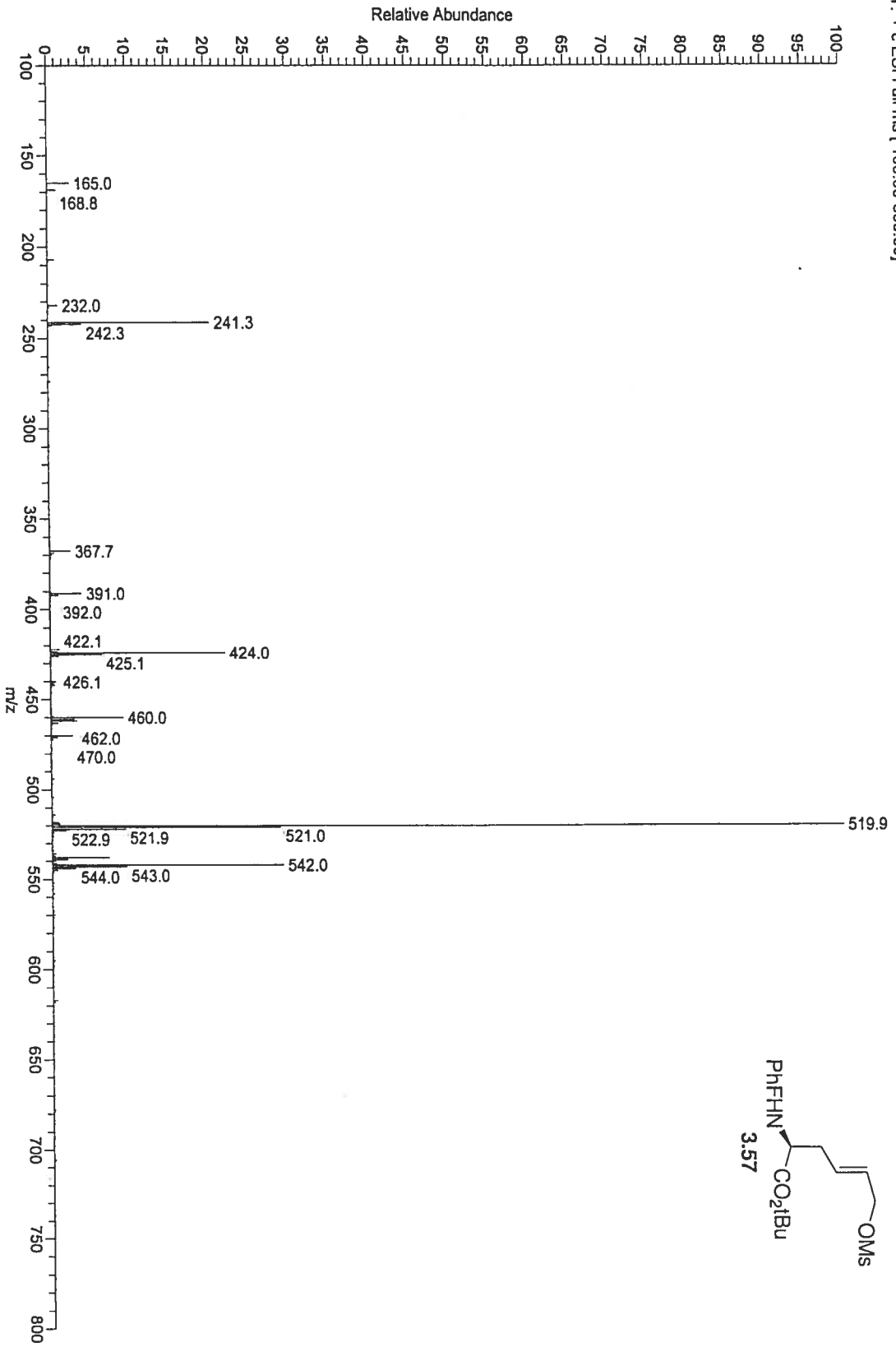



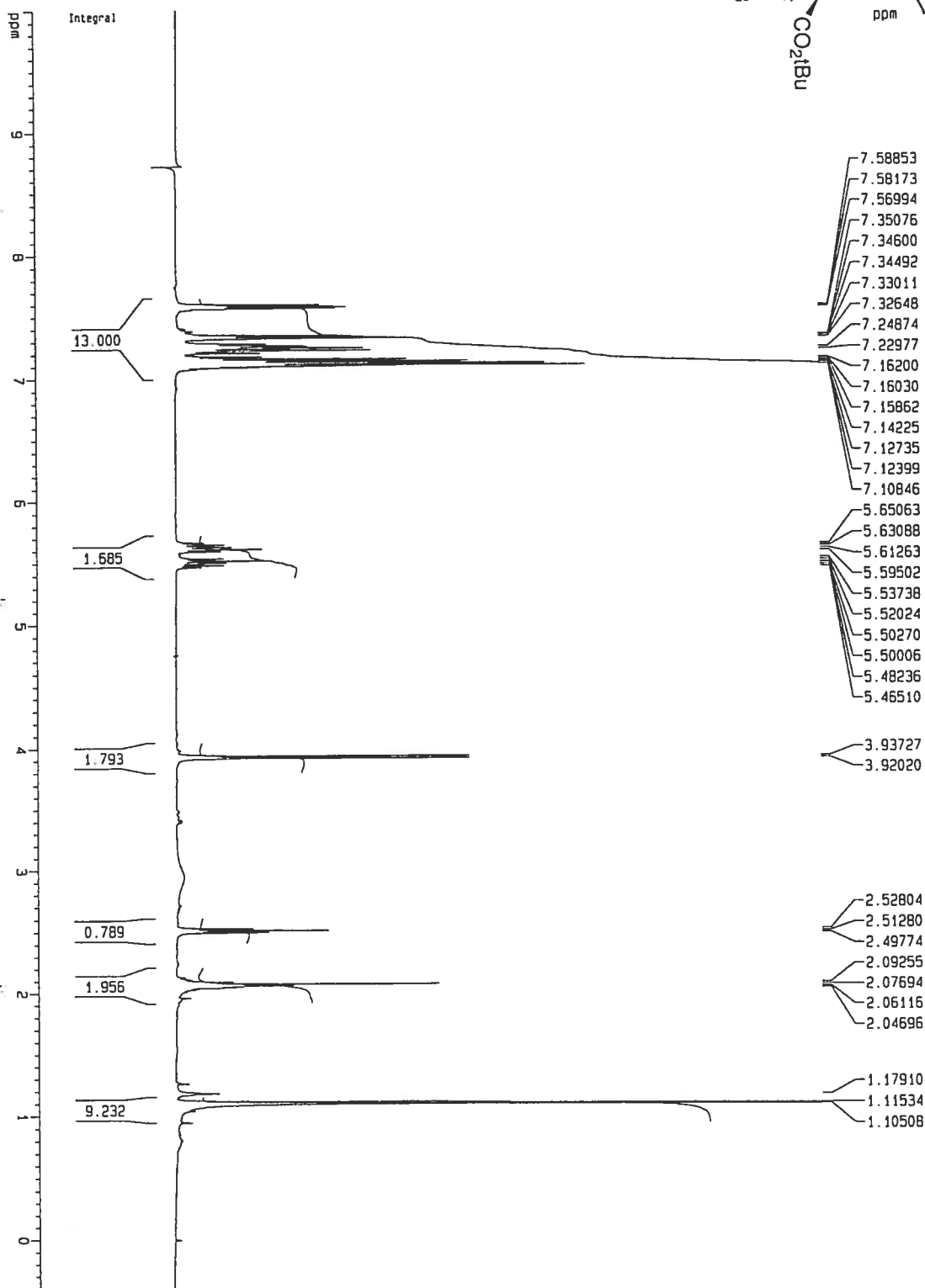
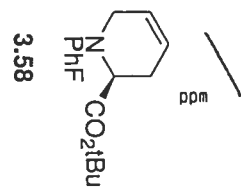

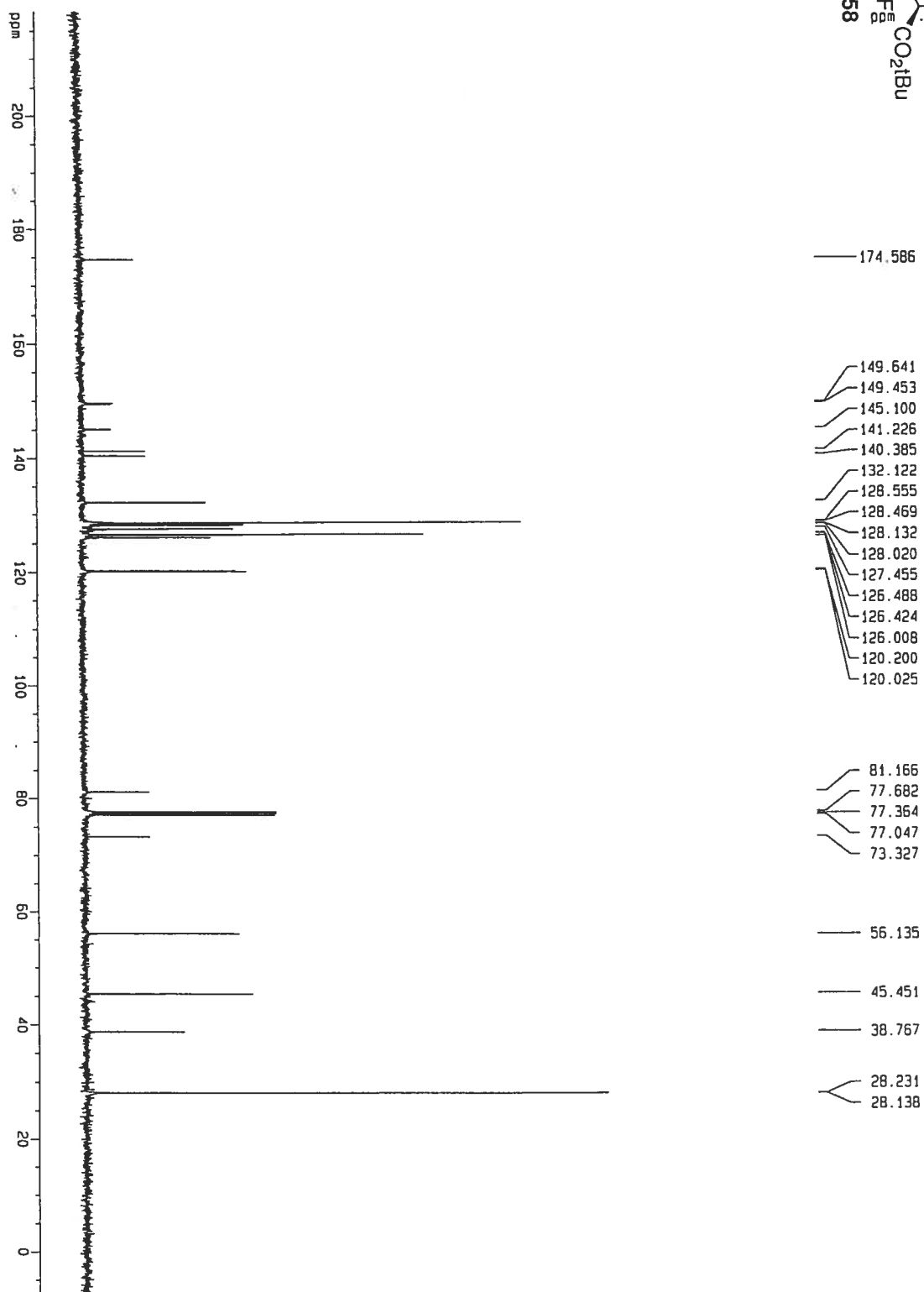
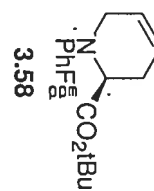

ci

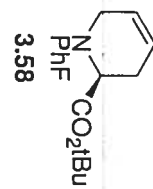

ppm

- 128.467
- 128.398
- 128.041
- 127.941
- 127.376
- 126.384
- 126.336
- 125.932
- 120.111
- 119.939

56.053

28.137



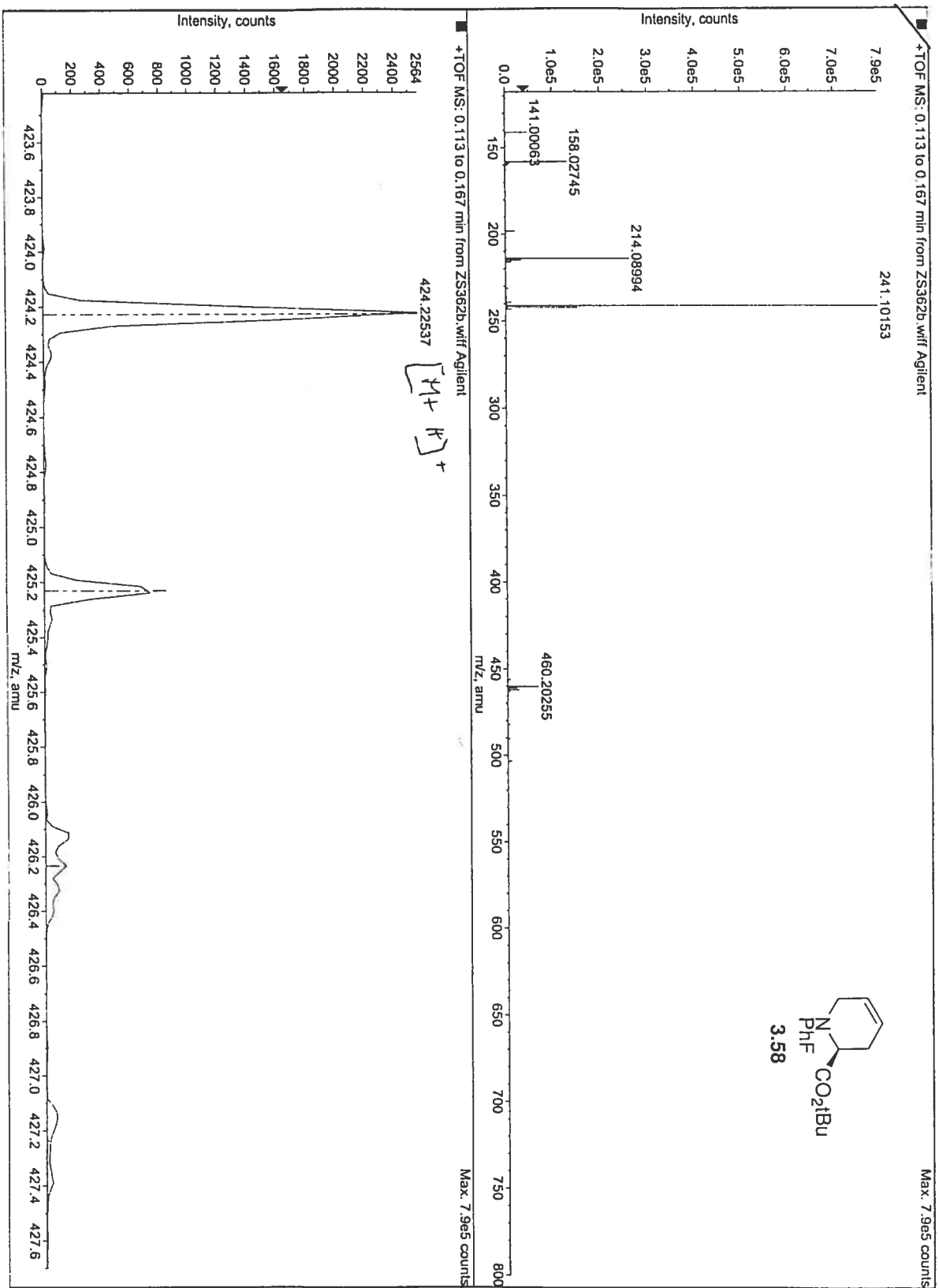

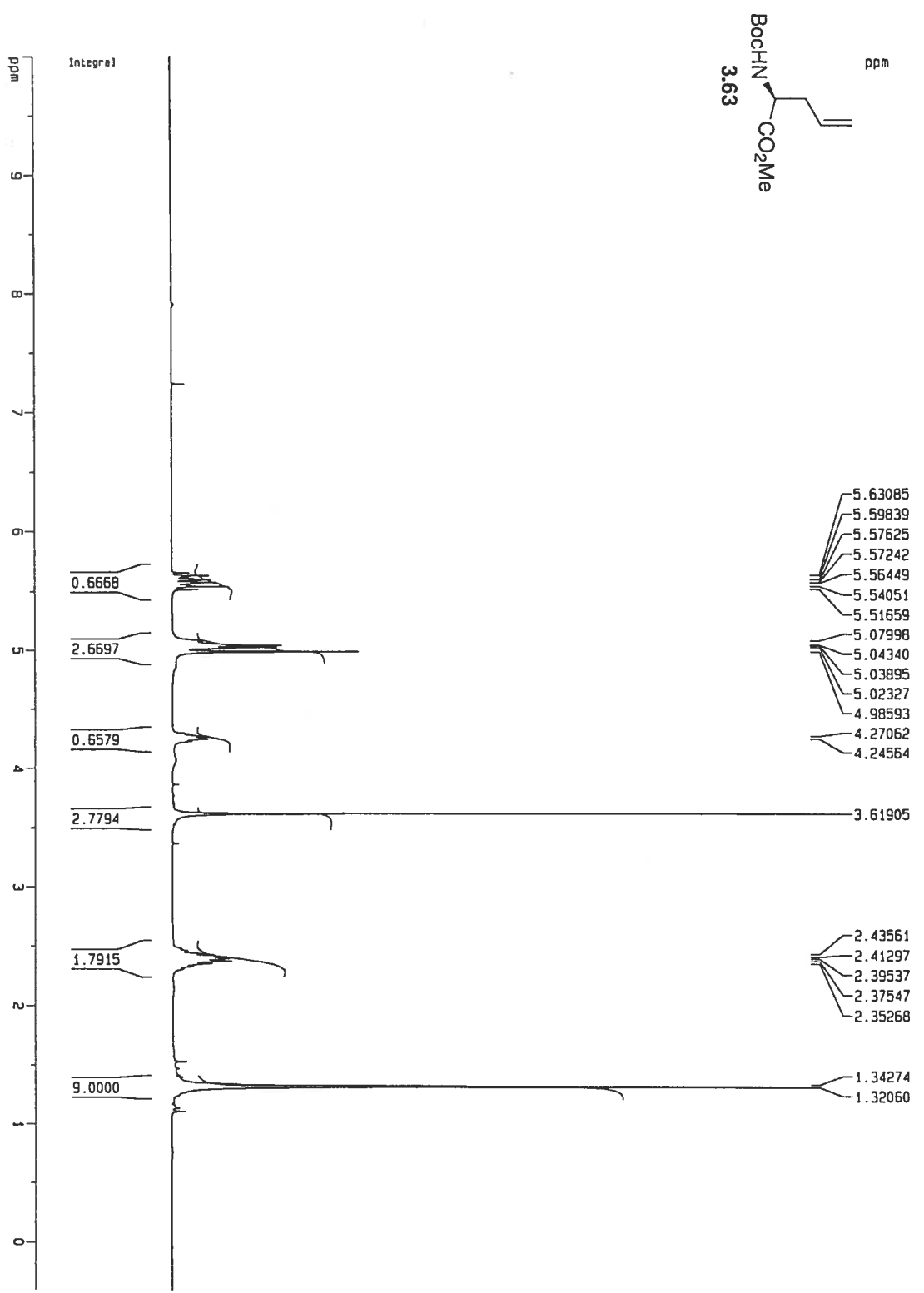

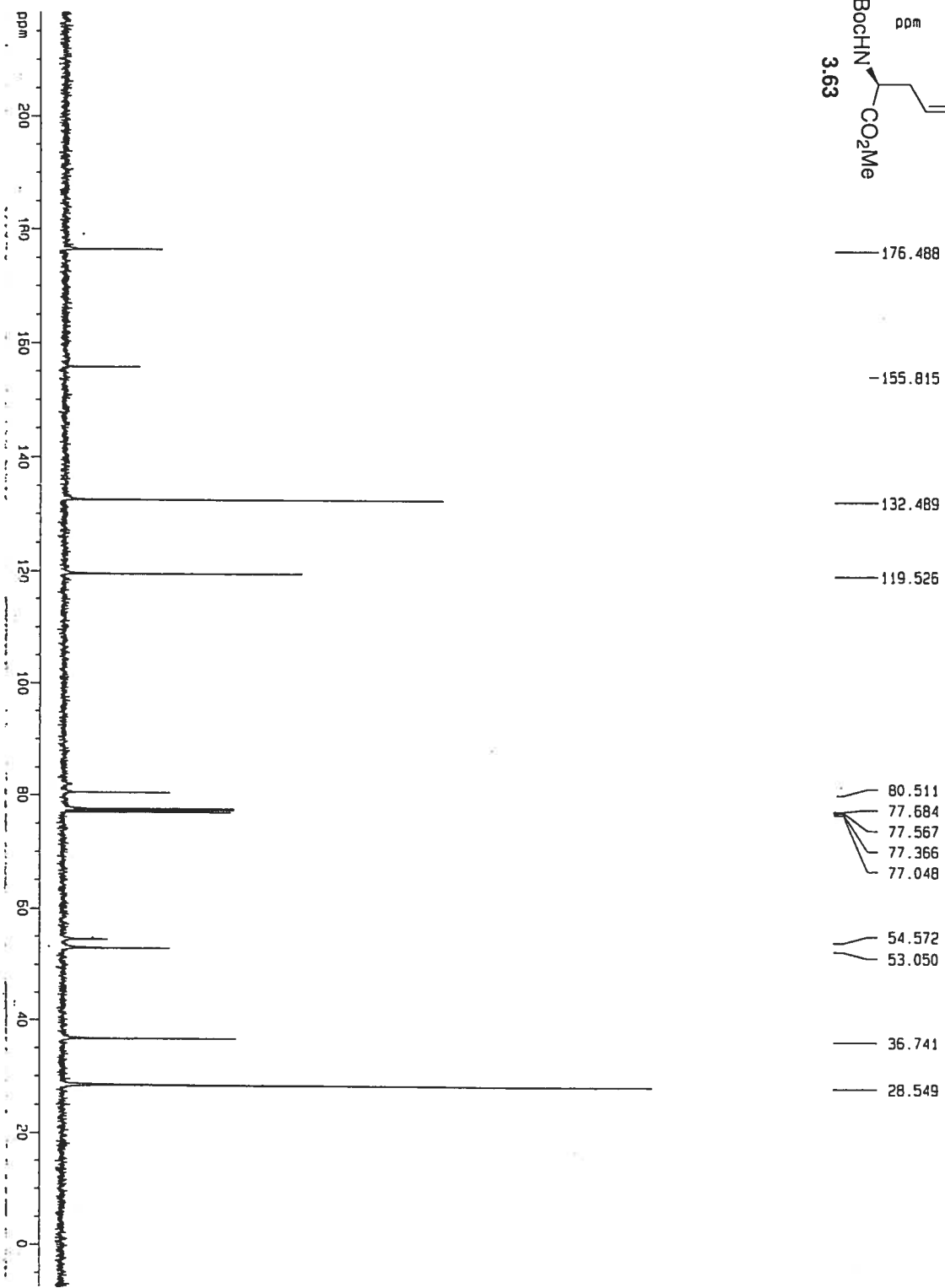
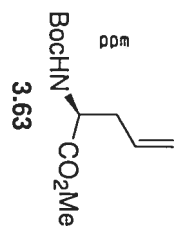

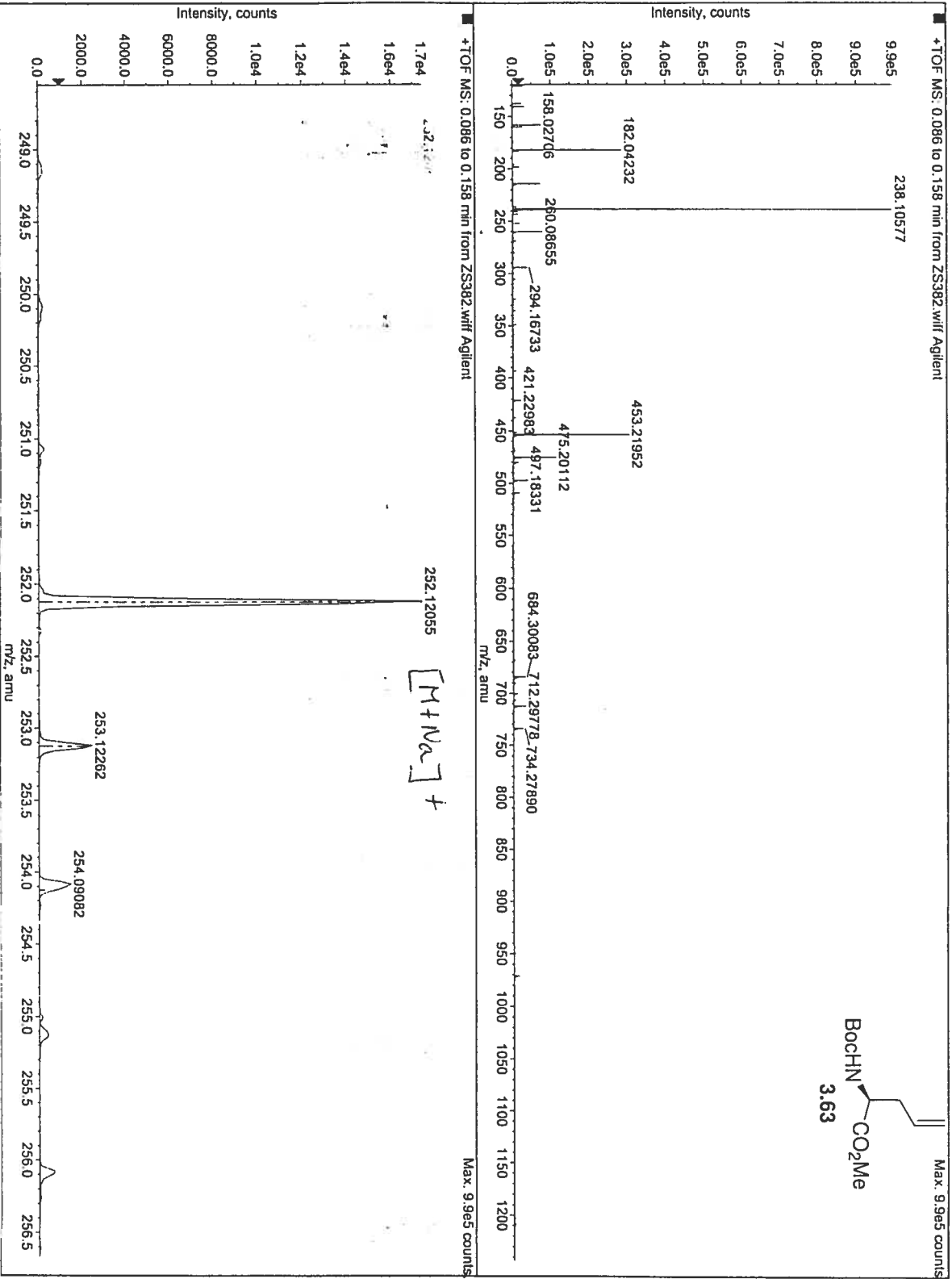
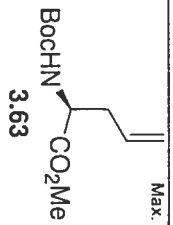

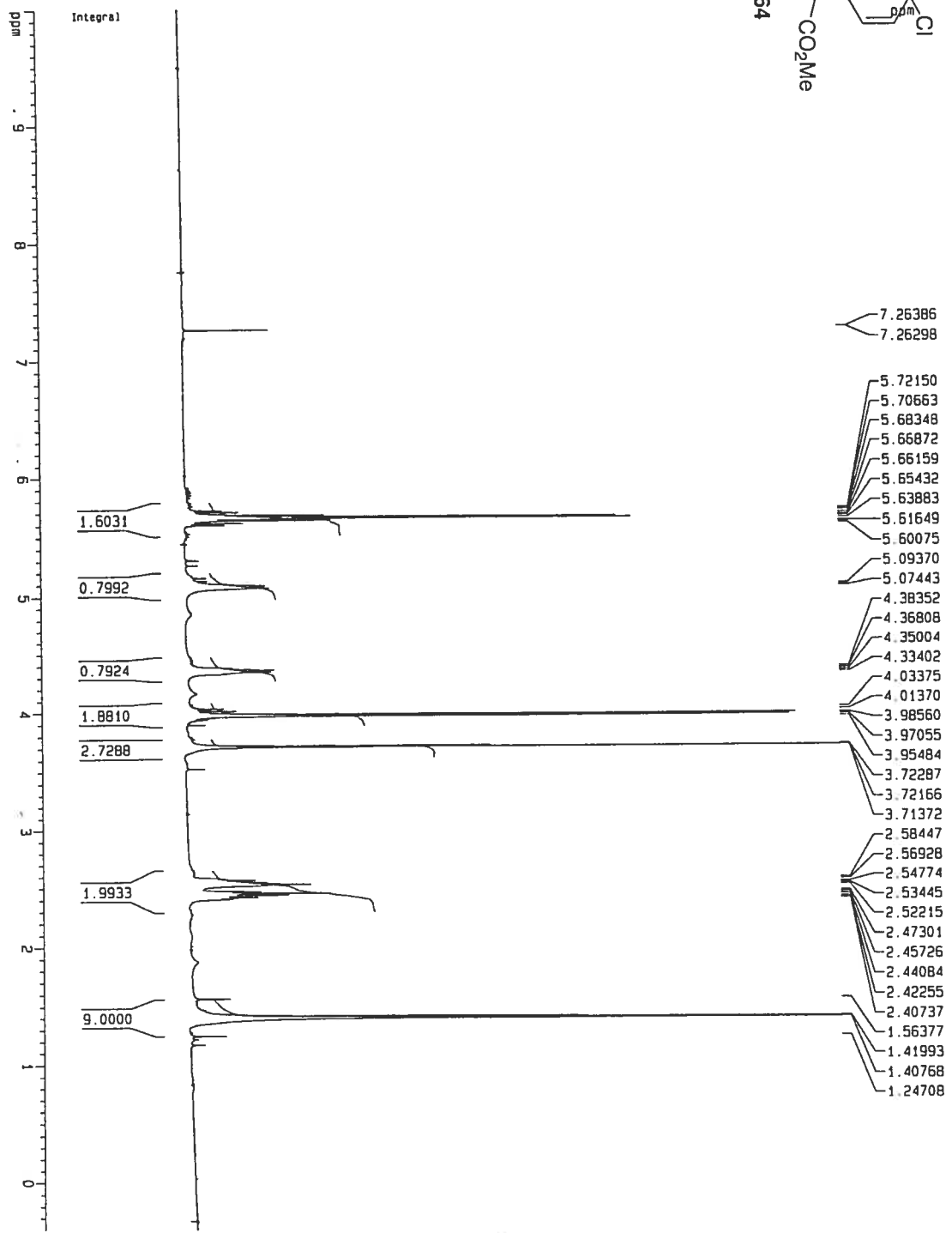
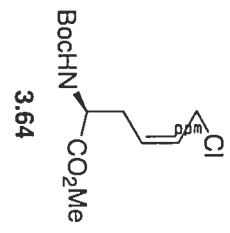

CVI



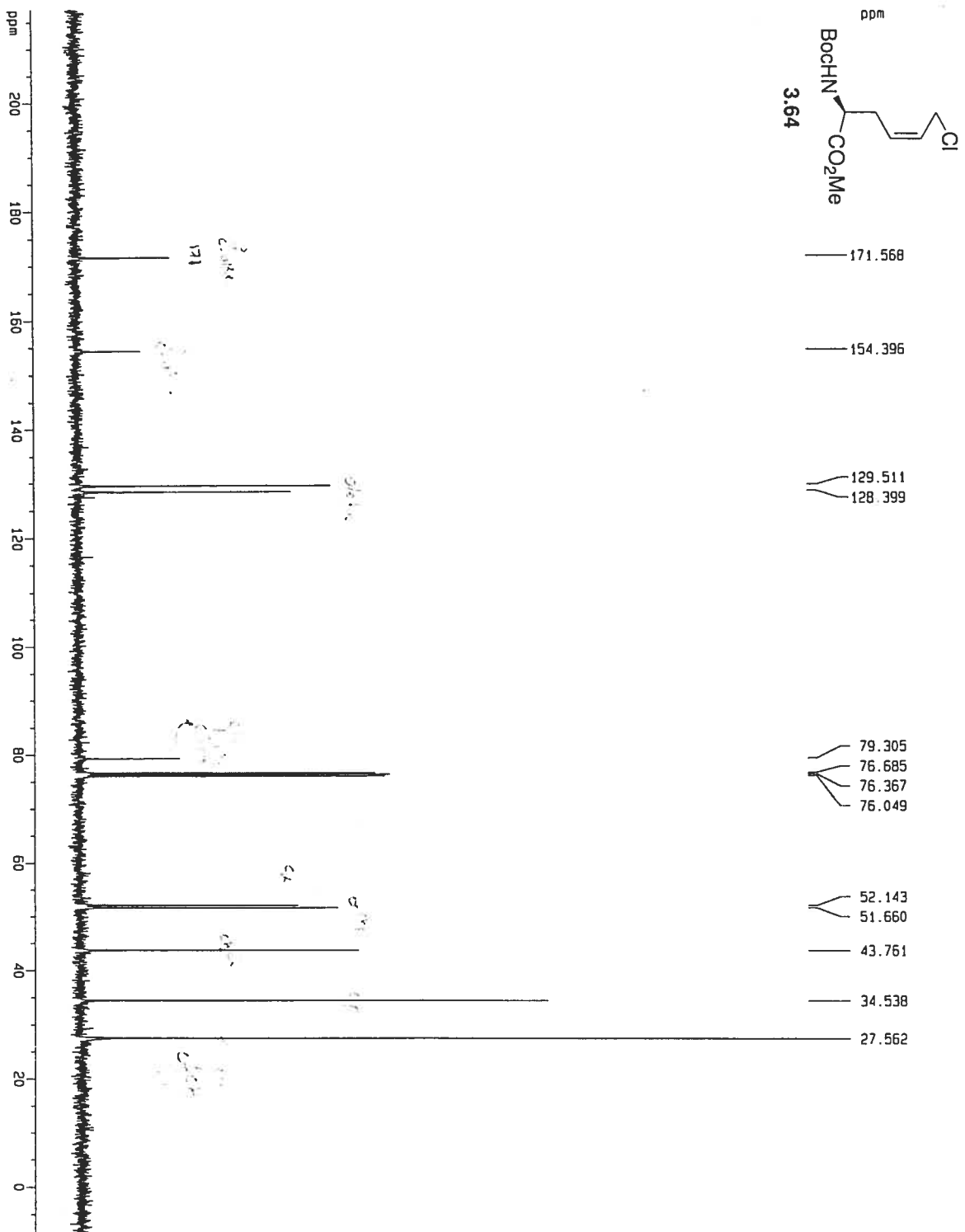

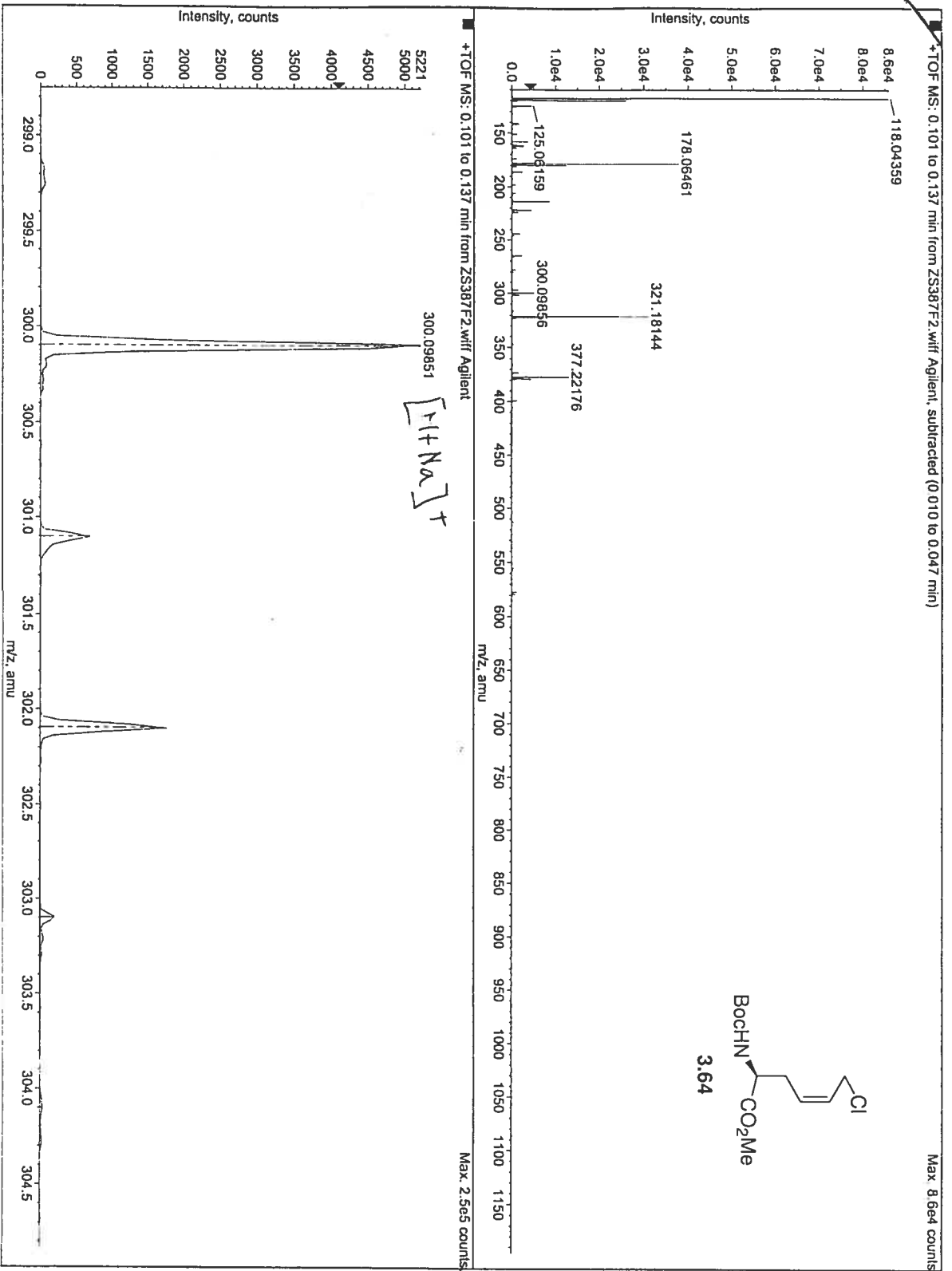

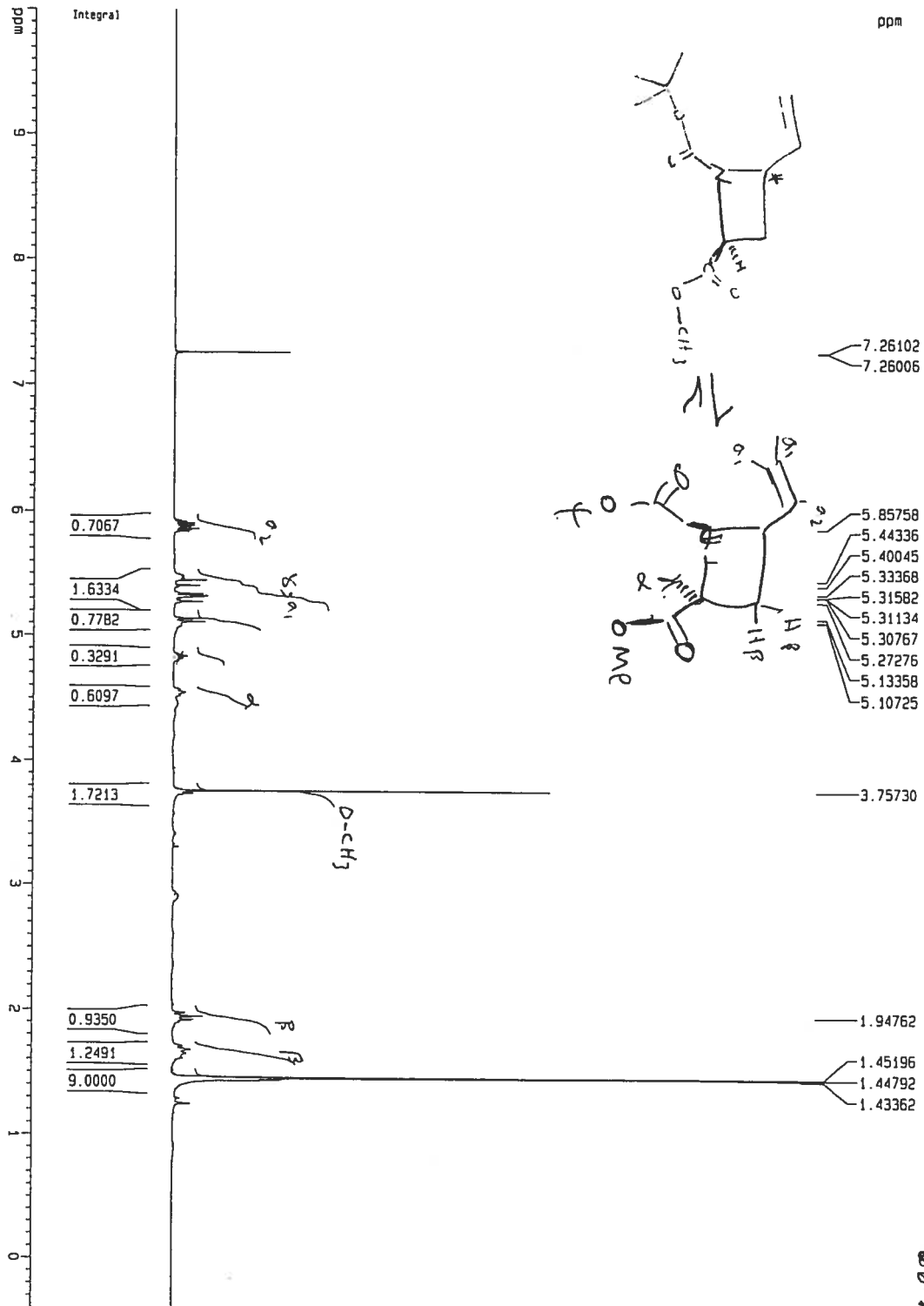

cix

ZS 368 m

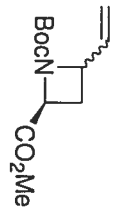

25°C

<sup>1</sup>H NMR 500 MHz  
25°C

3.65

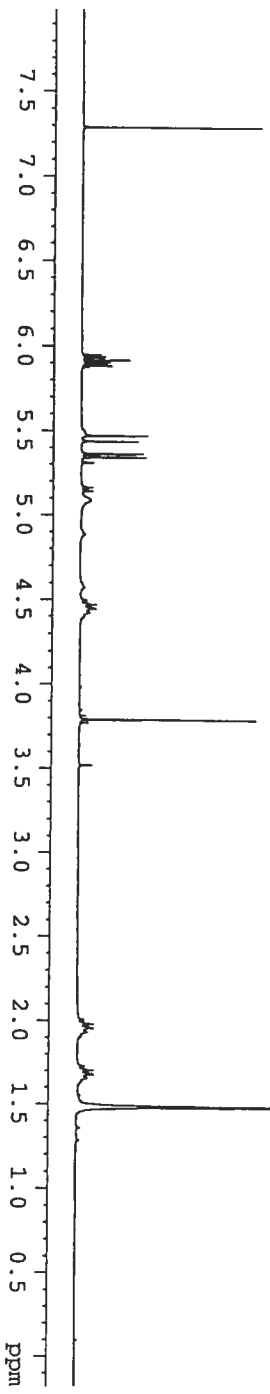
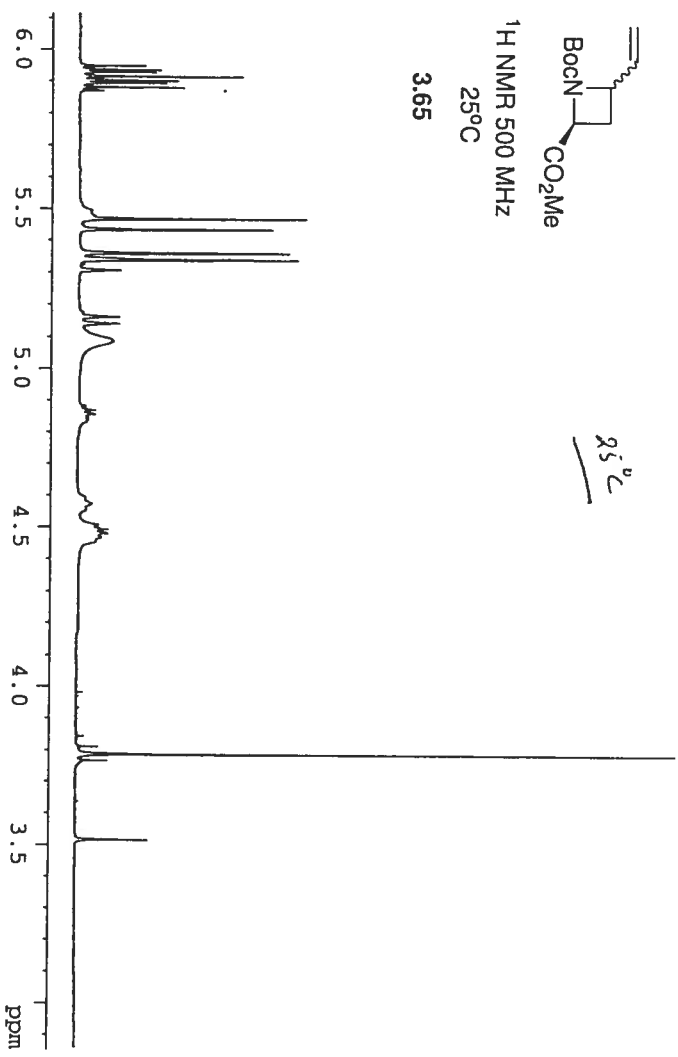

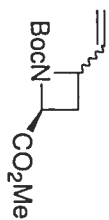

<sup>1</sup>H NMR 600 MHz  
-55°C

3.65

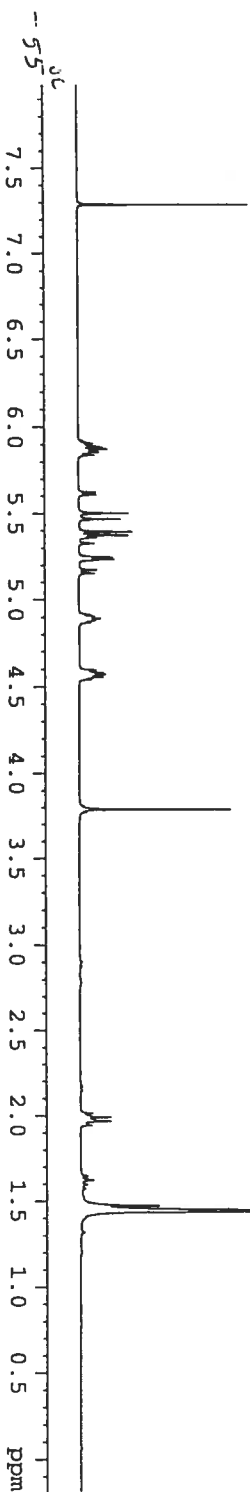
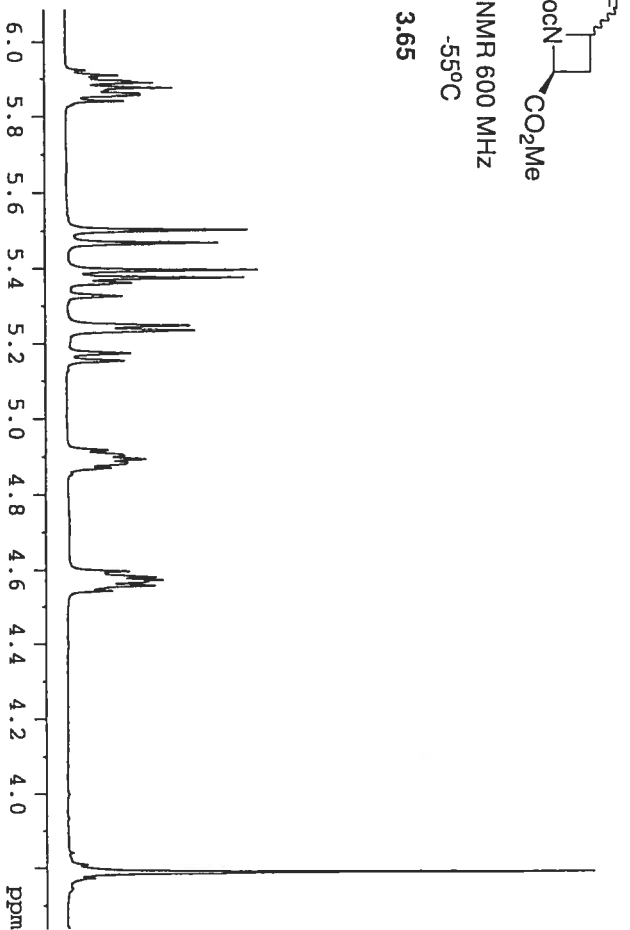

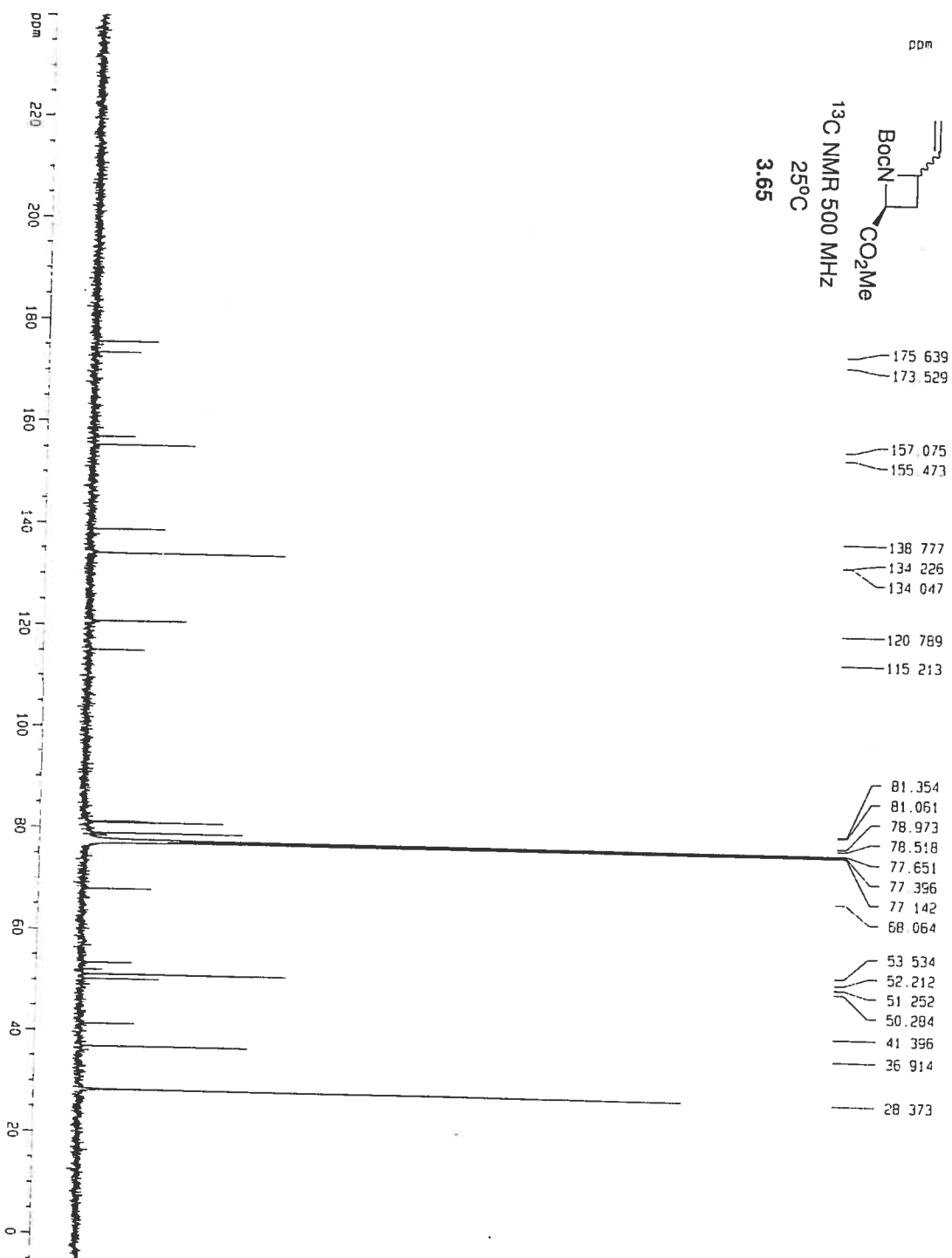

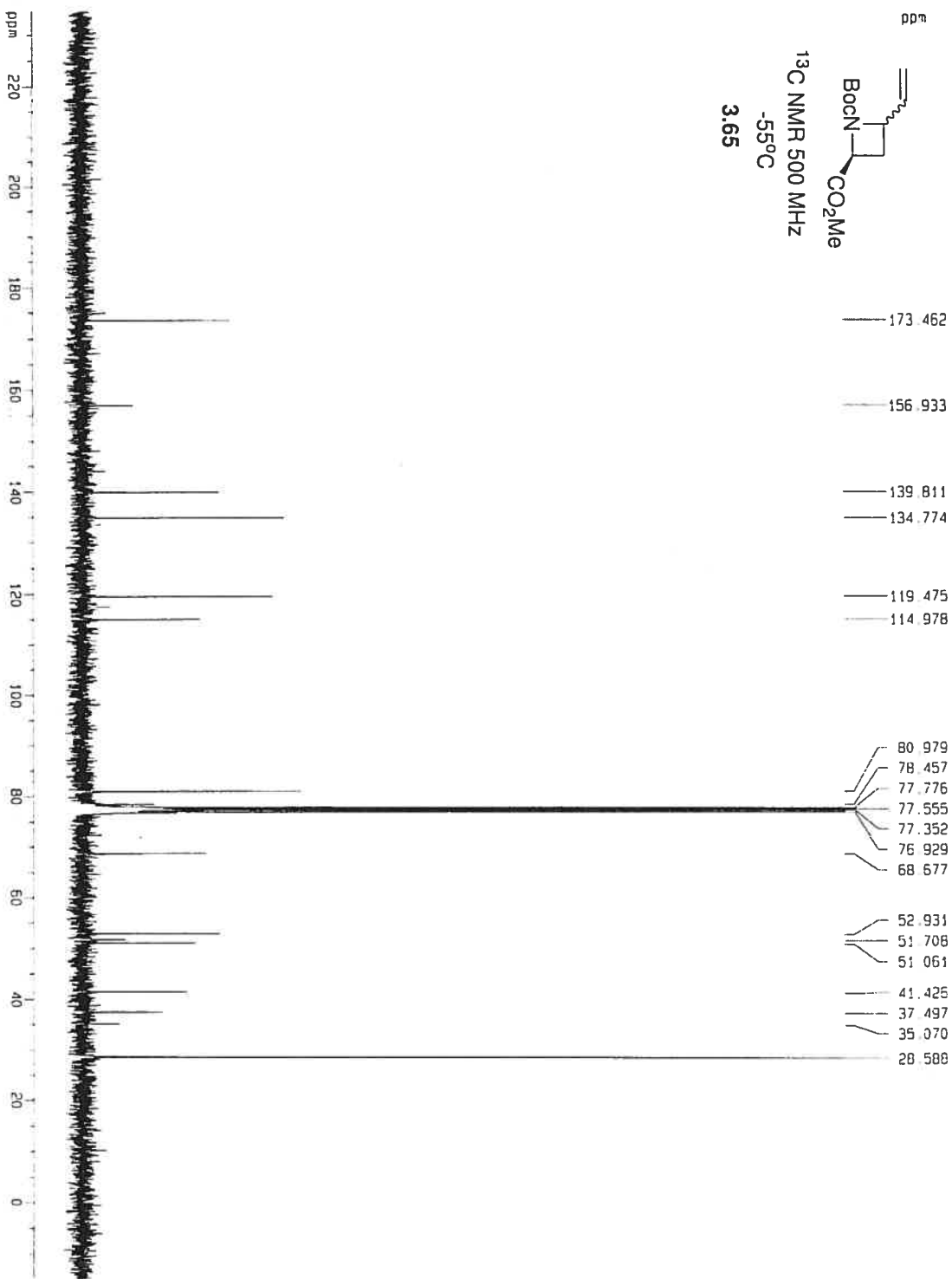

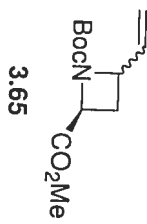
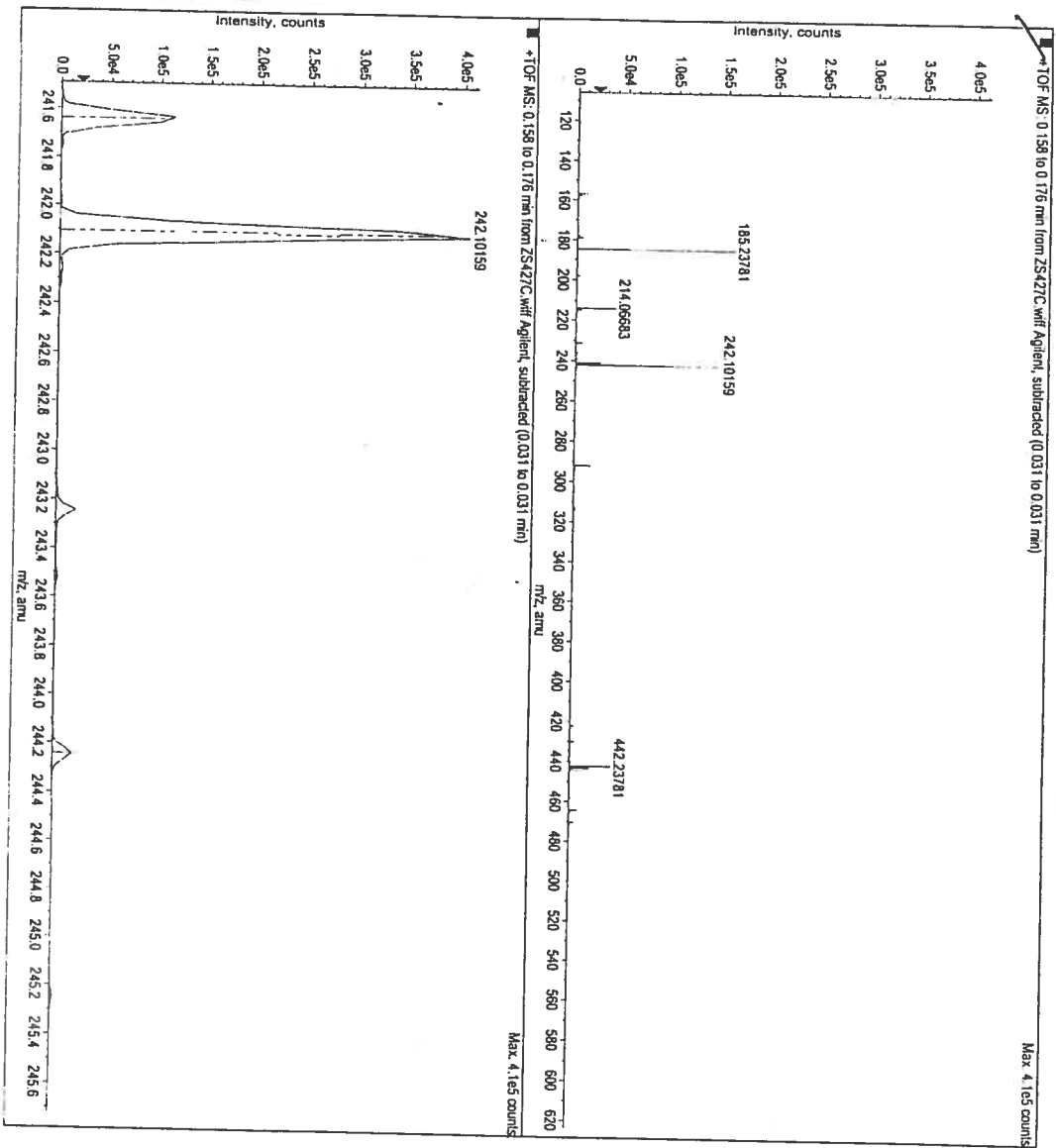



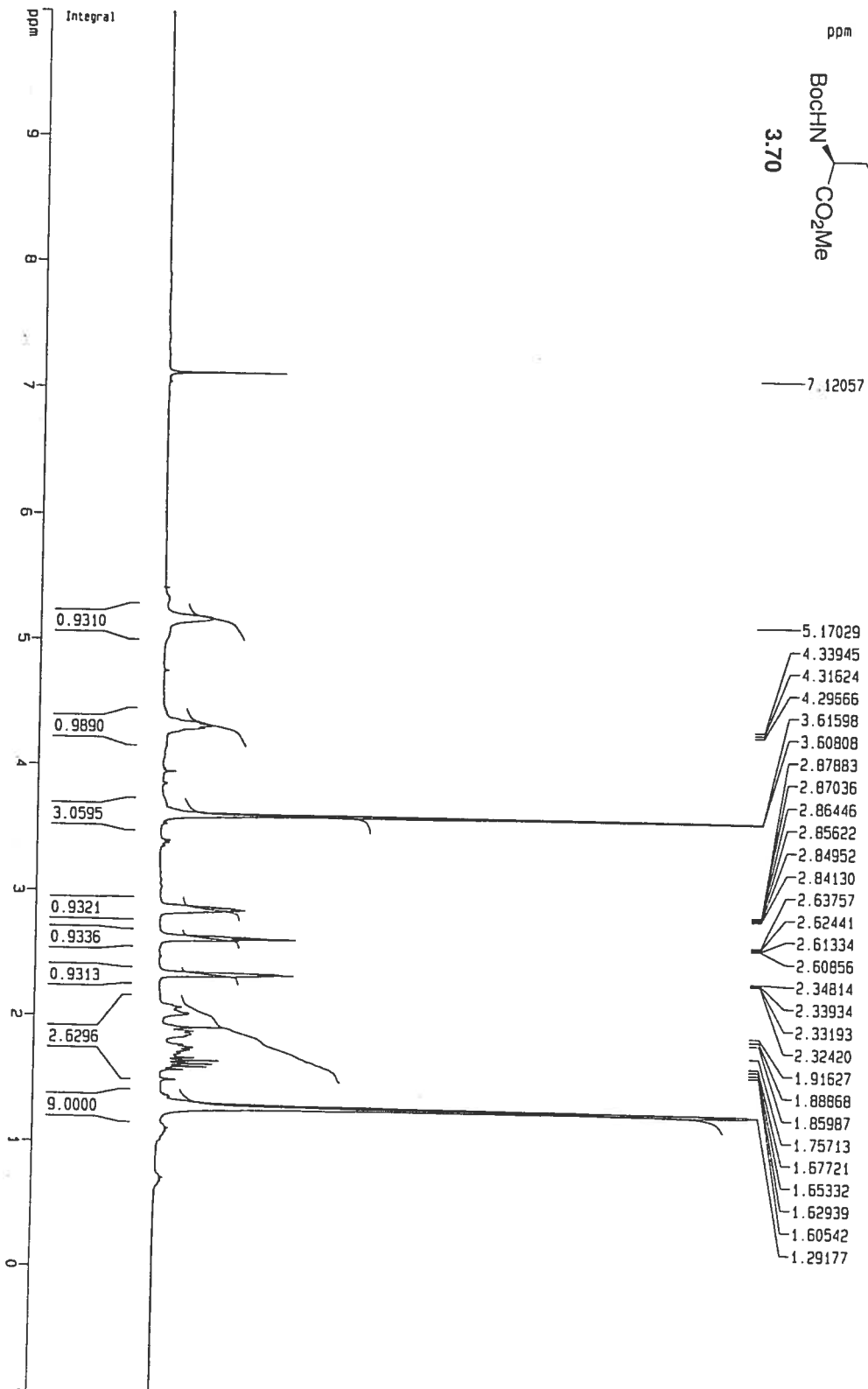

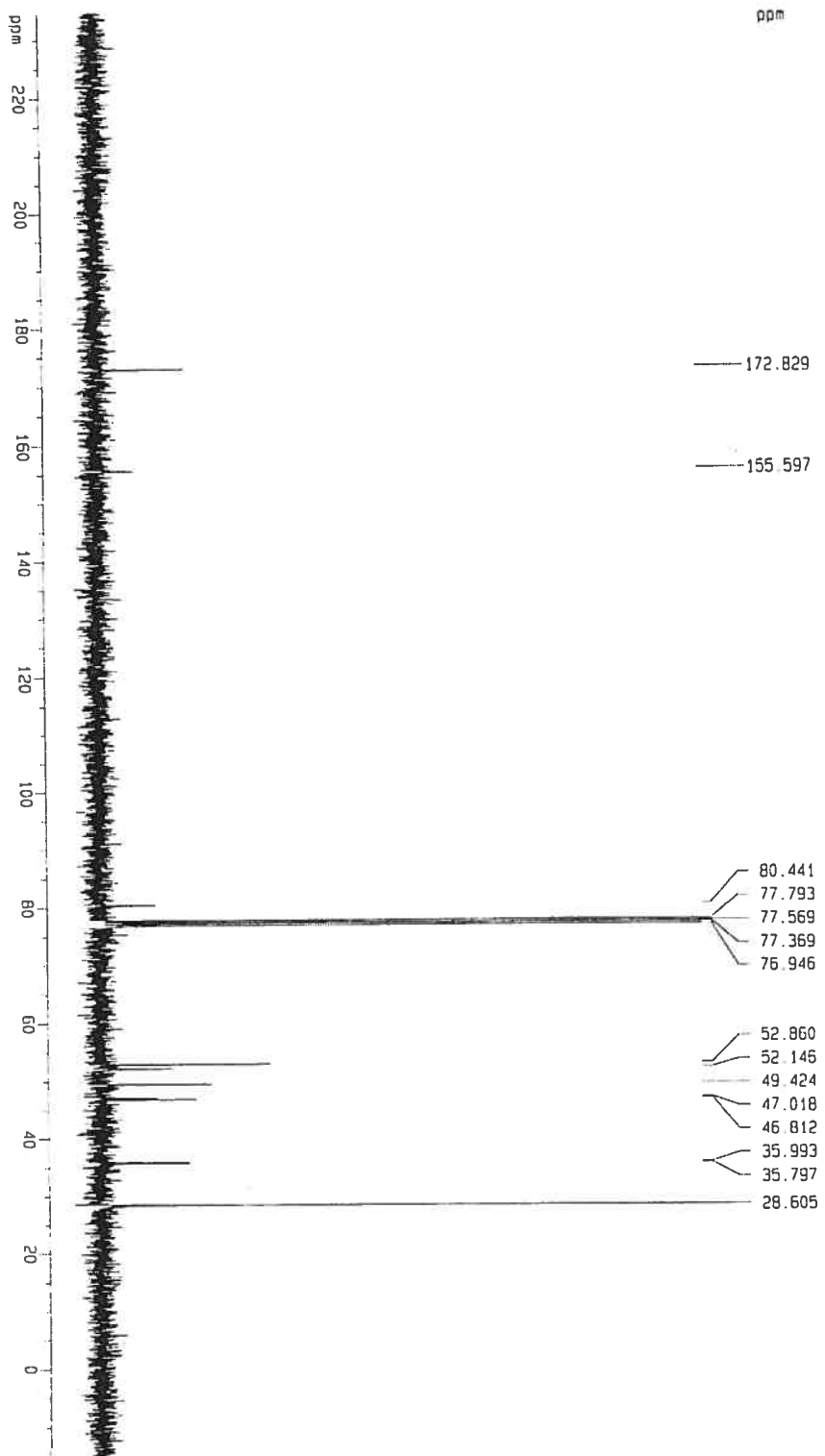
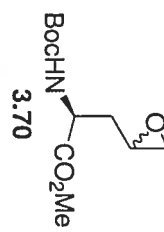

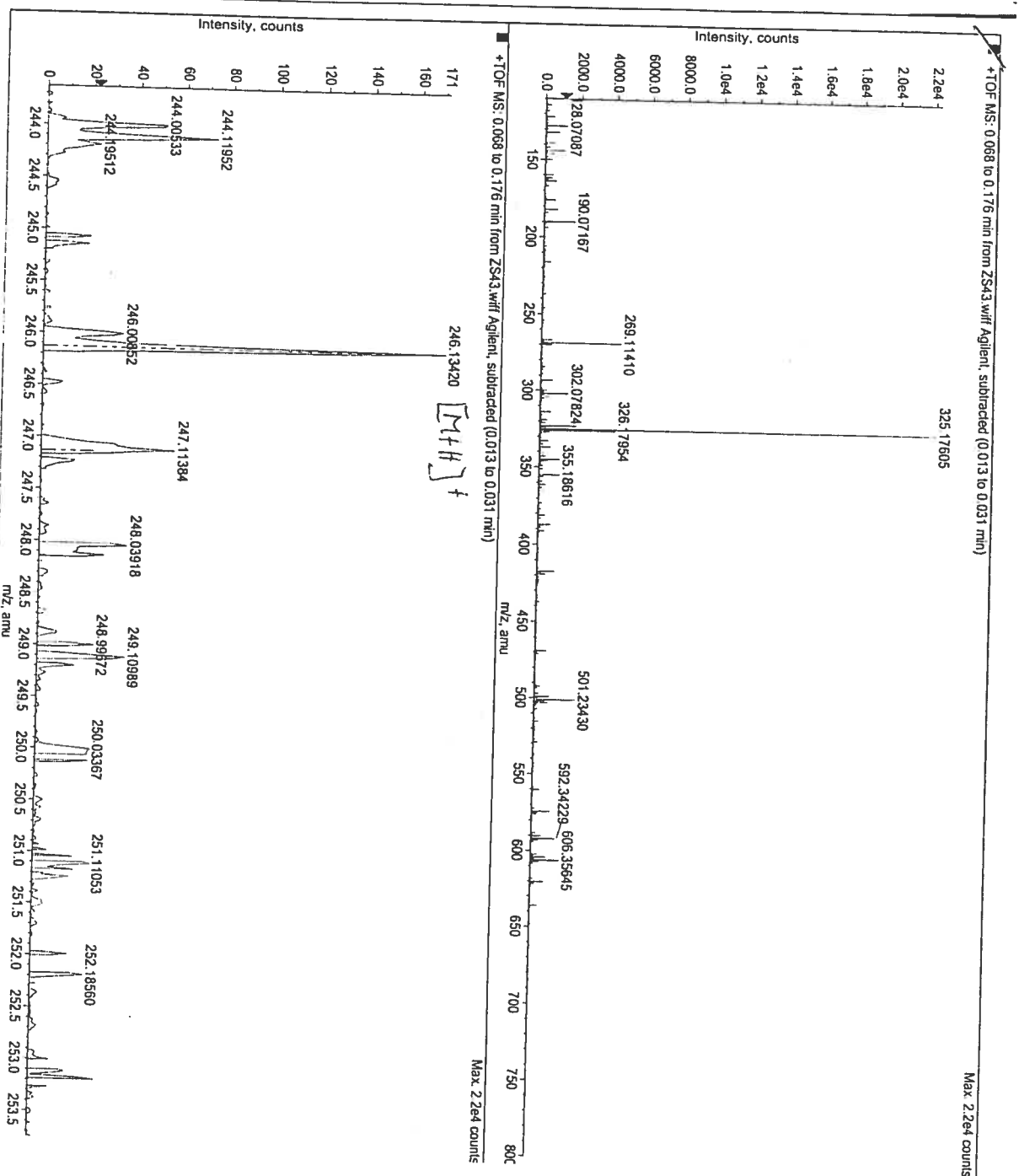
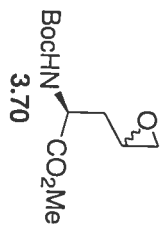

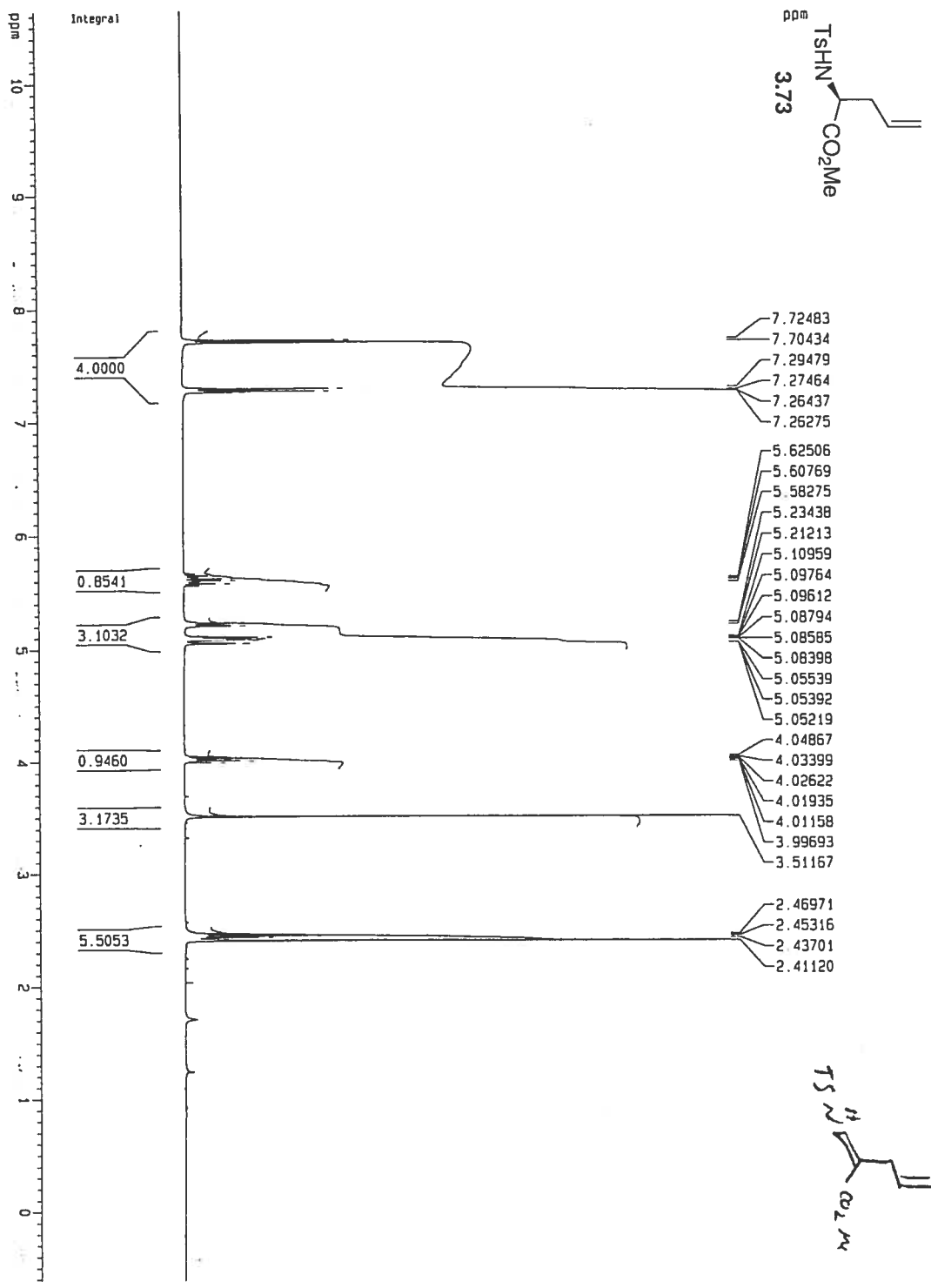

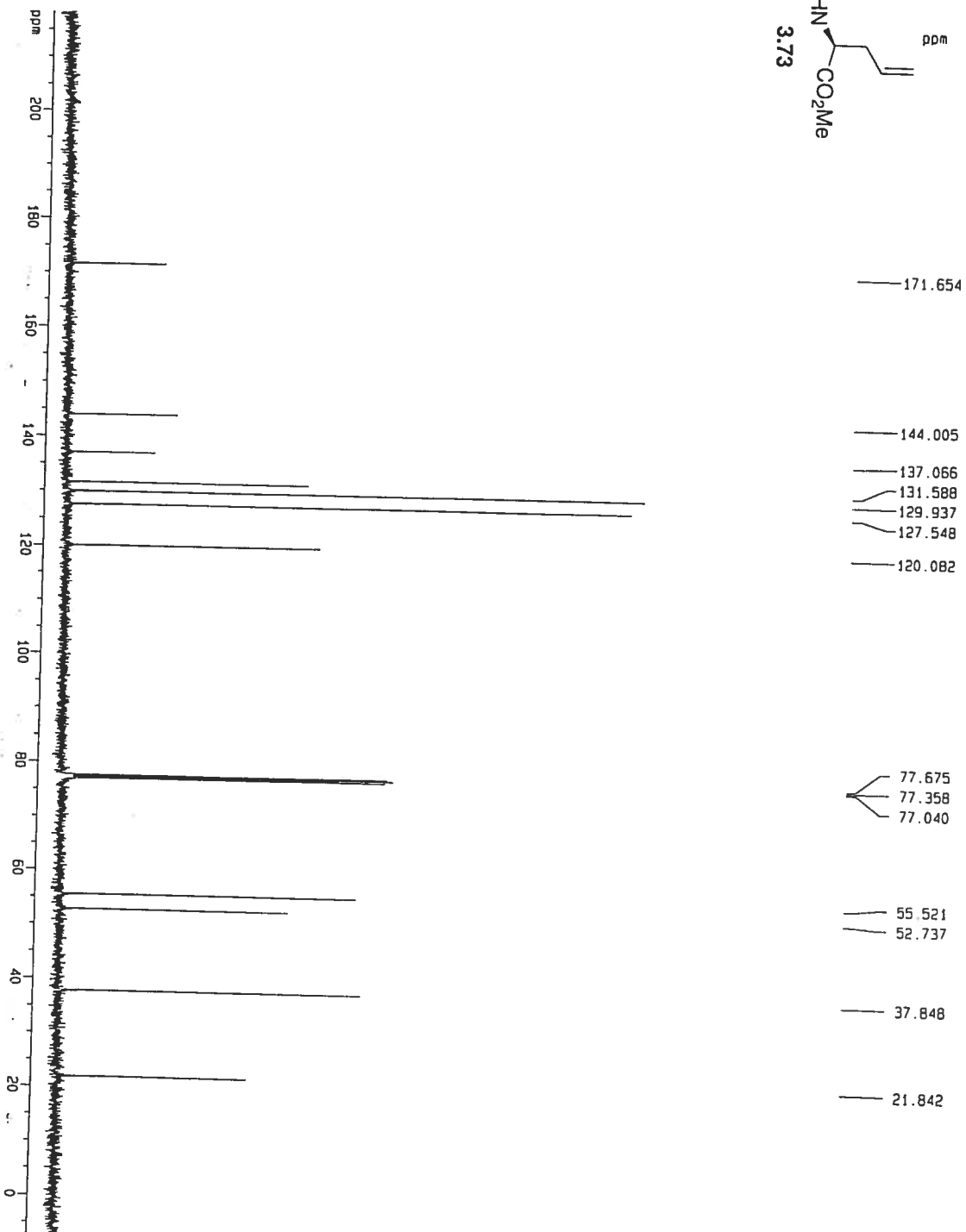
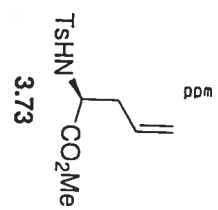

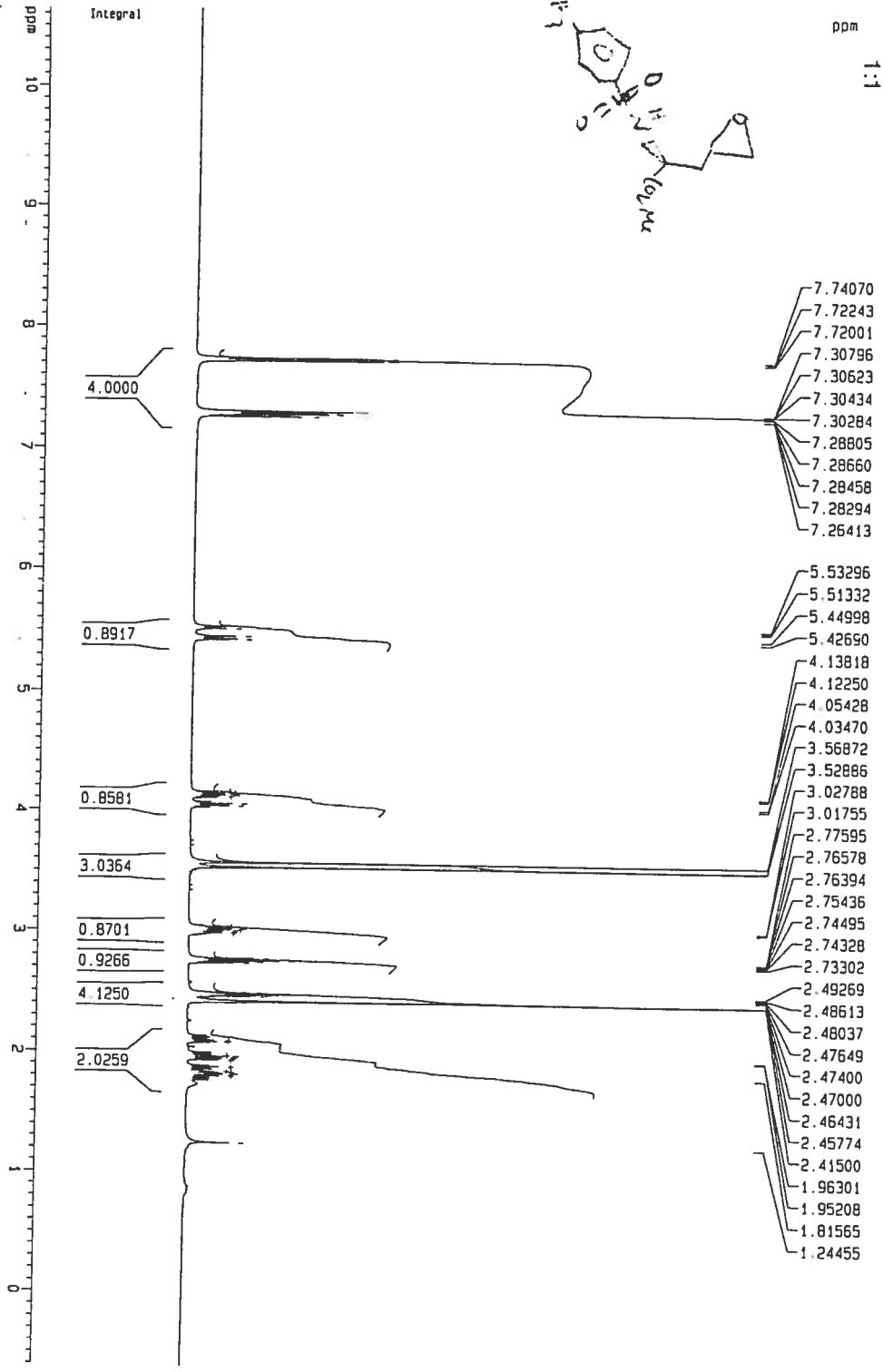
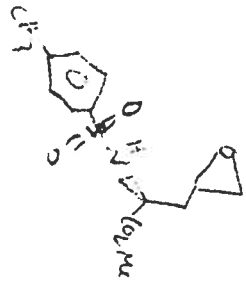
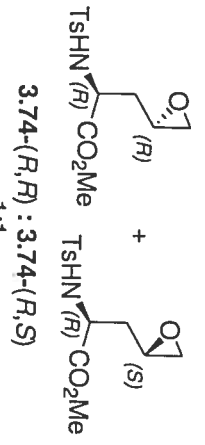

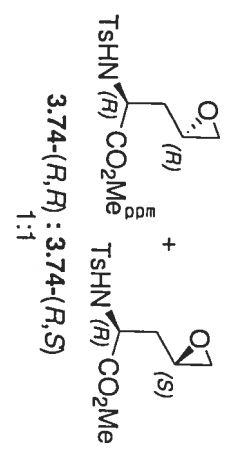

171.835  
171.686

144.186  
144.116  
136.863  
136.640  
130.054  
129.980  
127.576

77.671  
77.353  
77.036

54.195  
53.882  
53.119  
53.030  
49.060  
48.647  
47.372  
47.101  
36.805  
36.499  
29.996  
21.859

